

## Standard Mixer Cable Control - McNeilus Command Center™ Controls

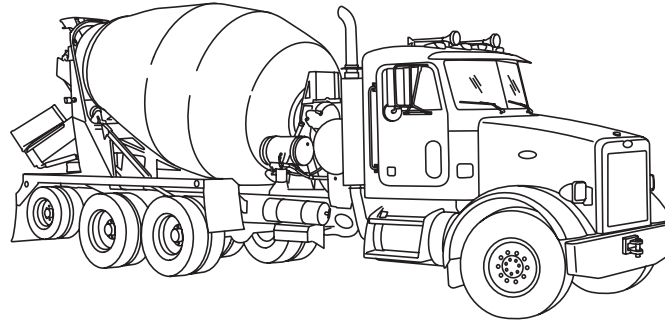

**Disclaimer:**

This manual must not be used to repair your vehicle. Repair information is available by calling McNeilus Customer Service at (888) 686-7278.

The information in this Operator's Manual will be your guide to operation and operator maintenance for this equipment.

All information, illustrations, and specifications in this manual are based on the information available at the time this manual was published. The illustrations used in this manual are intended as representative reference views only. Because of our continuous product improvement policy, we may modify information, illustrations, and/or specifications to explain and/or exemplify a product, service, or maintenance improvement. We reserve the right to make any change at any time without notice. Go to [www.streetsmartparts.com](http://www.streetsmartparts.com) for current information.

No part of this publication may be reproduced by any means - graphic, electronic, or mechanical, including photocopying, recording, taping, or information storage and retrieval systems for any use of purpose - without the written permission of McNeilus Truck and Manufacturing, Inc.

For assistance in ordering OSHA Publications, contact:

U.S. Department of Labor/OSHA

OSHA Publications

P.O. Box 37535

Washington, D.C. 20210

Telephone: 202-693-1888 • Fax: 202-693-2498

# 1.0 Identification

## 1.1 Mixer Identification Plate and TMMB Certification Placard

A McNeilus Truck and Manufacturing, Inc. identification plate (Figure 1, Item 1) is located on the left side of the front pedestal. The identification plate contains the serial number (Figure 1, Item 2) and the rated mix capacity (Figure 1, Item 3) of your mixer system.

The identification plate also contains the drum volume and water tank capacity.

Also located on the left side of the front pedestal is the Truck Mixer Manufacturers Bureau (TMMB) certification placard (Figure 1, Item 4). This decal indicates the certified maximum capacity of the Mixer.

The drum serial number (Figure 1, Item 5) is stamped into the pedestal.

Please fill out the following information and have it ready when calling McNeilus Truck and Manufacturing, Inc. for parts or product information:

**Date of Purchase:** \_\_\_\_\_

**McNeilus Branch:** \_\_\_\_\_

**Serial Number of Mixer:** \_\_\_\_\_

**Serial Number of Drum:** \_\_\_\_\_

**VIN\*** \_\_\_\_\_

\*Refer to chassis manufacturer literature for location.

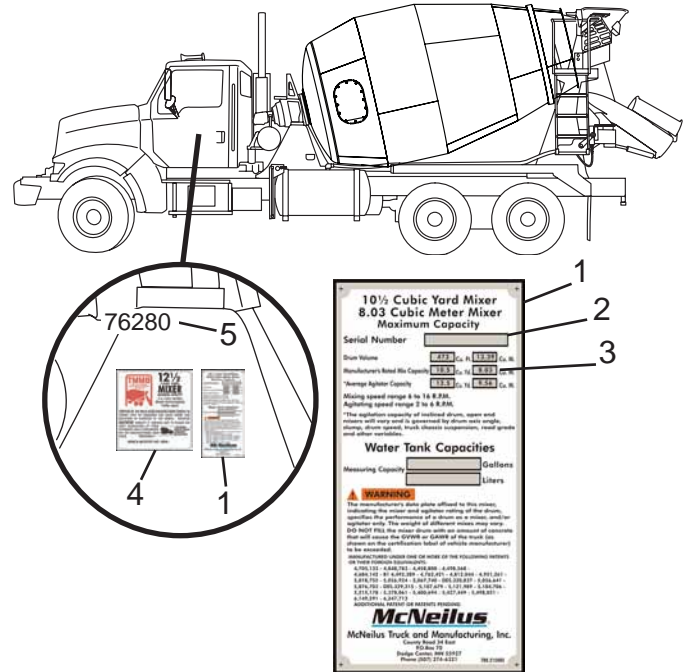

Figure 1

## 1.1.1 Mixer Serial Number Explanation

The Mixer Serial Number (Figure 2, Item 2) located on the identification plate (Figure 2, Item 1) will be needed when making service inquiries or when ordering parts.

The serial number is a five-digit sequential number, and contains no information such as Mixer build date, etc. This type of information is located on the Incomplete Vehicle Document Decal.

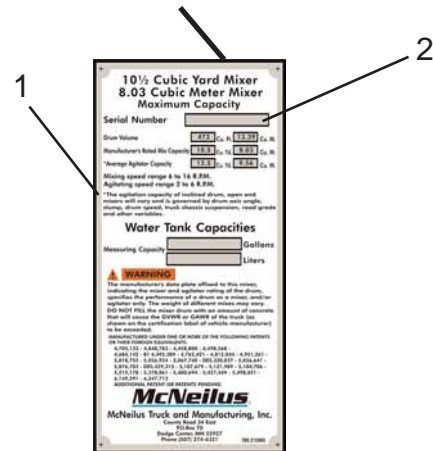
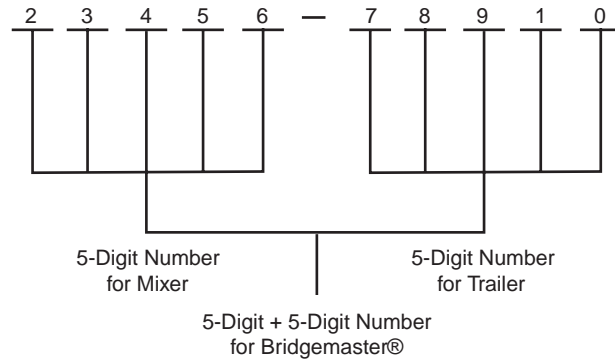

Figure 2

## 1.2 Complete Vehicle Document Decal

**NOTE**  
**The location of the Incomplete Vehicle Document decal may vary.**

The Complete Vehicle Document decal (Figure 3, Item 8) documents the axle load and tire ratings as the vehicle left the McNeilus production line. This decal is located inside the cab, and may be placed on driver's doorjamb, or seat riser.

This decal includes information such as the gross vehicle weight (Figure 3, Item 1), chassis manufacturer (Figure 3, Item 2), tire and rim size (Figure 3, Item 3), tire pressure specifications (Figure 3, Item 4), chassis build date (Figure 3, Item 5), vehicle (chassis) ID number (Figure 3, Item 6), mixer system build date (Figure 3, Item 7), and maximum rated weight per axle (Figure 3, Item 9).

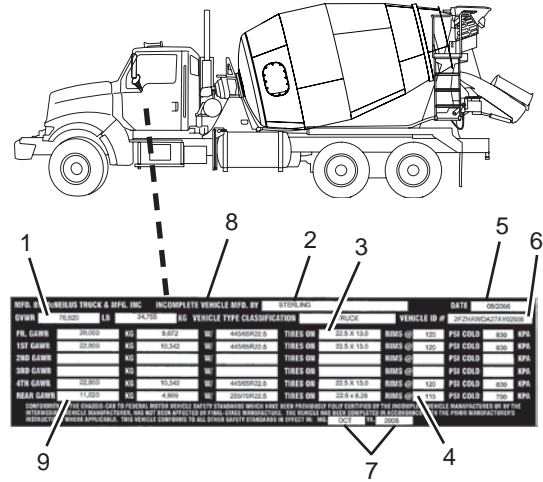

Figure 3

## 2.0 Purpose of Manual

This Operator Manual provides operation and operator maintenance instructions for the Standard Mixer manufactured by McNeilus Truck and Manufacturing, Inc.

The information in this operator manual will be your guide to operation and operator maintenance for this equipment.

**Keep this manual with the vehicle at all times.**

### **WARNING**

**The operator of this Mixer must be properly licensed and trained to operate this Mixer.**

**If you do not have the proper training and licensing to operate this Mixer, you are putting yourself and others at risk of serious injury or death.**

**If you are uncertain how to operate this Mixer, inform your supervisor or contact McNeilus Customer Service at 888-686-7278.**

### **NOTE**

**This manual is limited to the operation and light maintenance of the mixer system only.**

**Since the mixer system may be mounted on various chassis, this manual does not include the operation or maintenance of the chassis. Refer to the chassis manual provided with your Mixer for chassis operation and maintenance information.**

## 3.0 Scope

This manual provides information for use by the equipment operator under the following headings:

1. **Safety.** Includes important safety information.
2. **General.** Includes equipment identification.
3. **Operation.** Includes control functionality and normal equipment operation.
4. **Preventive Maintenance.** Includes basic preventive maintenance information for the operator.
5. **Troubleshooting.** Includes basic troubleshooting and diagnostic information for the operator.

To order a replacement manual or safety warning decals, call McNeilus at 888-686-7278 or visit [www.streetsmartparts.com](http://www.streetsmartparts.com).

## 4.0 Parts and Service

Contact your McNeilus Parts and Service branch locations to order parts, receive service information, or for other assistance.

Contact by phone or visit [www.streetsmartparts.com](http://www.streetsmartparts.com). We have factory owned parts and service centers near you.

<b>Phone Number</b>		<b>888-686-7278</b>	
<b>State</b>	<b>City</b>	<b>State</b>	<b>City</b>
AZ	Phoenix	MO	North Kansas City
CA	Collon	NC	High Point
CA	Stockton	NV	Las Vegas
CO	Denver	NY	Bronx
CT	East Granby	OH	Cincinnati
FL	Miami	OH	Columbus
FL	Tampa	PA	Morgantown
GA	Villa Rica	TX	Houston
IL	Sugar Grove	TX	Hutchins
IN	Fort Wayne	UT	West Valley City
LA	New Orleans	WA	Puyallup
MN	Dodge Center	WI	Oshkosh

### **Canada**

Ontario and Western Provinces	800-265-1089
Quebec and Maritime Provinces	800-996-4937

## 5.0 Corporate Headquarters

Contact McNeilus Truck and Manufacturing, Inc. directly at our corporate headquarters at the following address, phone number, and website.

McNeilus Truck and Manufacturing, Inc.  
524 County Road 34 East  
Dodge Center, MN 55927

Telephone: 507-374-6321

Corporate Website: [www.mcneiluscompanies.com](http://www.mcneiluscompanies.com)

Parts and Service Website: [www.streetsmartparts.com](http://www.streetsmartparts.com)

**This Page Intentionally Left Blank**

**SAFETY**

1.0 IMPORTANT SAFETY INFORMATION.....1

    1.1 Lockout/Tagout Procedures.....1

        1.1.1 Confined Space and Permit-Required Confined Space OSHA 1910.146 .....1

        1.1.2 Applying the Lockout/Tagout Procedure .....2

        1.1.3 Removing the Lockout/Tagout Procedure .....5

        1.1.4 Restoring Equipment to Normal Production Operations.....6

    1.2 Battery Cable Disconnect .....6

    1.3 Safety Equipment .....6

    1.4 Reporting Safety Defects.....7

2.0 PRODUCT SAFETY INFORMATION .....8

    2.1 Use Proper Safety Equipment.....9

3.0 SAFETY INFORMATION.....10

    3.1 Safety .....10

    3.2 Cab Operation .....12

    3.3 Outside Operation .....14

    3.4 Maintenance .....17

    3.5 Hydraulics.....20

    3.6 Electrical.....24

    3.7 Chute Extensions .....24

4.0 SAFETY DECALS.....26

    4.1 Safety Decal and Placard Locations.....31

        4.1.1 Curb Side Views .....31

        4.1.2 Street Side Views .....33

    4.2 Safety Decal Identification.....35

**GENERAL INFORMATION**

1.0 EXTERIOR SYSTEMS ARRANGEMENT.....65

    1.1 Curb Side View.....65

    1.2 Street Side View .....66

**OPERATION**

1.0 BEFORE PLACING THE MIXER INTO SERVICE.....67

    1.1 Transport Feature.....67

2.0 INSTRUMENTS AND CONTROLS .....69

    2.1 Electronic Drum Control System .....69

    2.2 Touch Screen Display Status Icons .....72

    2.3 Cab Controls - Cab Control Pendant.....75

    2.4 Fuse Functions.....76

    2.5 Outside Controls.....77

        2.5.1 Rear Pendant Controls.....78

        2.5.2 Drum Control .....79

        2.5.3 Manual Chute Lock.....80

2.6	Manual Drum Operation .....	81
2.6.1	Manual Override - CHARGE and DISCHARGE .....	81
2.7	OMNEX® Wireless Remote Control (Optional) .....	82
2.7.1	OMNEX® Wireless Remote Control (Cab Console Version) .....	82
	• 2.7.1.1 Control Buttons .....	83
2.7.2	LED Indicators .....	85
2.7.3	OMNEX® Wireless Remote Control (Plug and Play Version) .....	86
2.7.4	Transmitter.....	87
	• 2.7.4.1 Control Buttons .....	87
	• 2.7.4.2 LED Indicators .....	89
2.7.5	Cleaning the Transmitter .....	90
2.7.6	OMNEX® Wireless Remote Control (Optional) Troubleshooting.....	90
	• 2.7.6.1 Diagnostic Codes – Transmitter .....	90
2.7.7	Receiver Locations .....	92
	• 2.7.7.1 LED Indicators .....	92
	• 2.7.7.2 Normal Operation .....	93
	• 2.7.7.3 Fault Codes .....	94
3.0	MIXER OPTIONS .....	97
3.1	Hydraulic Fold-Over Chute .....	97
3.2	Chute Assist.....	98
3.3	Hydraulic Chute Swing .....	100

3.4	Discharge Chute Vibrator Valve .....	101
3.5	Chute Blockers .....	102
3.6	Foldover Stop .....	103
3.7	Composite Chute Extension .....	104
3.8	Flip-Up Charge Hopper .....	104
3.9	SAT (Swing Away Throat) Charge Hopper .....	105
3.10	Concrete Slump Meter.....	106
3.10.1	Setting the Mechanical Concrete Slump Meter .....	107
3.10.2	Setting the Digital Concrete Slump Meter .....	108
	• 3.10.2.1 Adding a Slump Point .....	108
	• 3.10.2.2 Deleting a Slump Point.....	109
3.11	Trimble® Mobile Solutions Crosscheck System .....	110
3.12	Safety Vision System.....	110
3.13	Eagle Eye™ Electronic Obstacle Detection System .....	111
3.14	Central Lubrication Systems.....	112
4.0	CHASSIS OPTIONS.....	114
4.1	Pusher Axles.....	114
4.1.1	Raising or Lowering Pusher Axle.....	115
5.0	CONTROL FUNCTIONS .....	116
5.1	Hopper Function .....	116
5.2	Chute Lock Function.....	117

5.3	Chute Raise/Lower and Swing Functions.....	118
5.4	Work Lighting Functions .....	119
5.5	Add Water Function .....	120
5.5.1	Manual Water Injection System.....	120
5.5.2	Remote Water Injection System .....	121
6.0	WATER TANKS .....	122
6.1	Water Tank Safety .....	122
6.2	Water Tank Operation.....	122
6.2.1	Introduction.....	122
6.2.2	Daily Operation.....	123
6.2.2.1	Tank Integrity .....	123
6.2.2.2	Pressure Regulator Valve.....	123
6.2.2.3	Pressure Relief Valve .....	124
6.2.3	Daily Operation.....	124
6.2.4	Vehicle Handling Characteristics.....	124
6.3	Water Tank Decal Identification .....	125
6.4	Water Tank Mounting Positions .....	126
6.5	Standard Water Tank.....	126
6.5.1	Single Sight Gauge.....	126
6.6	Split Water Tank (Optional).....	126
6.6.1	Dual Sight Gauges .....	127

---

7.0 WATER SYSTEM - PRESSURIZED.....	127
7.1 Depressurizing the Water Tank.....	127
7.2 Pressurizing the Water Tank.....	128
7.3 Draining the Water System.....	129
7.4 Filling the Main Tank.....	132
7.5 Filling the Chemical Tank (Split Tank Option).....	133
8.0 WATER SYSTEM - PUMP.....	134
8.1 Pump Operation - Steel or Aluminum Tanks.....	134
8.2 Filling the Water Tank.....	136
8.3 Filling the Chemical Tank - Steel or Aluminum Tanks (Split Tank Option).....	137
8.4 Draining the Water System.....	139
9.0 WATER SYSTEM FUNCTIONS.....	142
9.1 Wash-Out Hoses.....	142
9.1.1 Upper Wash-Out Hose (Optional).....	142
9.1.2 Front Wash-Out Hose (Optional).....	142
9.1.3 Valve Drain (Optional).....	143
9.2 Spray Bar (Optional).....	144
9.3 Water Meter Function (Optional).....	145
9.3.1 Precision Water Meters.....	145
9.3.2 BR Industries (BM-25) Water Meter.....	146
9.3.3 GPI® Water Meters.....	147

---

9.3.4	UFM Water Meters .....	148
9.3.5	Operation.....	148
10.0	OPERATING PROCEDURES .....	149
10.1	Start-Up Procedure.....	149
10.2	Warm-Up Procedure.....	149
10.3	Drum Operation .....	150
10.3.1	Drum Control Function .....	150
10.4	Adjusting the Throttle Speed .....	151
10.4.1	Paccar, Navistar, and Detroit Diesel Engines .....	151
10.4.2	Mack® Engines – Rear Pendant .....	151
10.4.3	Cummins® Engines .....	152
10.5	Loading the Mixer Drum .....	152
10.6	Traveling to the Job Site .....	153
10.7	Positioning the Truck for Discharge.....	154
10.8	Chute Operation .....	154
10.8.1	Unfold the Fold-Over Chute.....	154
10.8.2	Using Chute Extensions .....	156
10.8.3	Position the Discharge Chute Assembly.....	157
10.9	Discharging the Load.....	158
10.10	Wash Down the Mixer Before Leaving the Job Site .....	158
10.11	Returning from the Job Site .....	161

10.12	End-of-Day Cleaning Procedure.....	162
10.12.1	Standard (Steel) Drum.....	162
10.12.2	End-of-Day Checks .....	163
 <b>PREVENTIVE MAINTENANCE</b>		
1.0	PREVENTIVE MAINTENANCE .....	165
1.1	DOT Pre-Trip .....	165
2.0	PREVENTIVE MAINTENANCE INTERVALS .....	165
3.0	DAILY CHECKS .....	172
3.1	Safety Decals .....	172
3.2	Hydraulic System.....	172
3.2.1	Hydraulic Oil Level.....	173
3.2.2	Hydraulic System and Components .....	173
3.2.3	Hydraulic Hoses and Pipes .....	174
3.3	Electrical System.....	176
3.3.1	Lighting System .....	176
3.3.2	Wire Harnesses .....	177
3.4	Pneumatic System.....	177
3.4.1	Pneumatic Lines and Fittings .....	177
3.4.2	Coalescing Filter.....	177
3.5	Mechanical System .....	179
3.5.1	Mixer Components and Pedestals.....	179

3.5.2	Water Tanks.....	180
3.5.3	Wheel Lug Nut Torque.....	181
3.5.4	Chute Extensions .....	182
3.5.5	Chute Assist.....	182
3.6	Standard (Steel) Drum.....	183
3.6.1	Standard (Steel) Drum Inspection .....	184
3.6.2	Concrete Removal.....	186
3.7	Operation.....	187
3.7.1	Mixer Controls .....	187
4.0	HYDRAULIC SYSTEM .....	188
4.1	Hydraulic Oil Requirements.....	188
4.2	Hydraulic Oil Reservoir.....	188
4.2.1	Hydraulic Oil Level.....	190
4.3	Adding Hydraulic Oil .....	190
5.0	OPTIONAL EQUIPMENT .....	191
5.1	Spray Bar Strainer .....	191
5.2	GPI® Water Meters .....	192
5.2.1	Battery Replacement.....	192
5.3	Optional Pusher Axle Maintenance .....	192
6.0	LUBRICATION .....	193
6.1	Daily Lubrication .....	193

6.2 Daily Lubrication – Remote Lubrication System (If Equipped) .....193

6.3 Daily Lubrication – Central Lubrication Systems .....195

6.4 Weekly Lubrication .....197

6.5 Semi-Annual Lubrication .....199

**TROUBLESHOOTING**

1.0 INTRODUCTION .....201

2.0 TROUBLESHOOTING CHART.....202

    2.1 Control System .....202

    2.2 Electrical System .....203

    2.3 Water System – Pressurized .....205

    2.4 Water System – Pump.....205

    2.5 Pneumatic System.....206

    2.6 GPI® Water Meter .....206

    2.7 BR Industries Water Meter (Optional) .....206

    2.8 UFM Water Meter .....207

**FORMER CABLE CONTROL SUPPLEMENT**

1.0 INSTRUMENTS AND CONTROLS .....209

    1.1 Cab Controls.....209

        1.1.1 Rocker Switch Functions .....210

        1.1.2 Indicator Light and Display Functions.....212

    1.2 Fuse Functions .....213

1.3	Outside Controls .....	215
1.3.1	Rear Control Pendant.....	216
	• 1.3.1.1 By-Passing the Rear Pendant .....	217
1.3.2	Drum Control .....	218
1.4	OMNEX® Wireless Remote Control (Optional) .....	220
1.4.1	OMNEX® Wireless Remote Control (Cab Console Version) .....	220
	• 1.4.1.1 Control Buttons and Switches .....	221
1.4.2	LED Indicators .....	223
1.4.3	OMNEX® Wireless Remote Control (Plug and Play Version) .....	224
1.4.4	Transmitter.....	225
	• 1.4.4.1 Control Buttons .....	225
	• 1.4.4.2 LED Indicators .....	227
1.4.5	Cleaning the Transmitter .....	228
1.4.6	OMNEX® Wireless Remote Control (Optional) Troubleshooting.....	228
	• 1.4.6.1 Diagnostic Codes – Transmitter .....	228
1.4.7	Receiver Locations .....	230
	• 1.4.7.1 LED Indicators .....	230
	• 1.4.7.2 Normal Operation .....	231
	• 1.4.7.3 Fault Codes .....	232

**This Page Intentionally Left Blank**

## 1.0 Important Safety Information

**READ AND UNDERSTAND THIS ENTIRE MANUAL BEFORE OPERATING, REPAIRING, OR ADJUSTING YOUR MCNEILUS EQUIPMENT.**

**THOSE WHO USE AND MAINTAIN THIS EQUIPMENT MUST BE THOROUGHLY TRAINED AND FAMILIAR WITH THE PRODUCT.**

**IF INCORRECTLY USED OR MAINTAINED, THIS EQUIPMENT CAN CAUSE SEVERE INJURY.**

Always keep this manual in a location where it is readily available for persons who operate or maintain the product. Additional copies of this manual are available from McNeilus Truck and Manufacturing, Inc. Please contact McNeilus Truck and Manufacturing, Inc. if you require additional manuals of if you have any questions about the information in this manual, this product, or safe operating procedures.

**THESE SAFETY PROCEDURES ARE FOR YOUR OWN PROTECTION.**

Do not operate this equipment until you have read its contents thoroughly. Read and understand the NRMCA manual that is placed in the vehicle's cab. Please contact McNeilus Truck and Manufacturing, Inc. if you require assistance.

Should operators of this equipment have a reading or learning disability, dyslexia, or other such condition, they must be assigned a mentor/trainer to read and explain to them the entire contents of this manual as well as the safety guidelines, danger, caution, and warning decals on this unit. Such

individuals should not be allowed to operate this equipment until they thoroughly understand all of these materials. Failure to do so can result in serious injury or death.

Safety and safe working procedures must be followed at all times.

### 1.1 Lockout/Tagout Procedures

OSHA LOCKOUT/TAGOUT procedures must be followed when performing Daily Checks or Scheduled PM on this equipment. If you are unfamiliar with the OSHA LOCKOUT/TAGOUT procedures or any other safety requirements, please contact McNeilus Truck and Manufacturing, Inc. Please contact McNeilus Truck and Manufacturing, Inc. if you require assistance.

#### 1.1.1 Confined Space and Permit-Required Confined Space OSHA 1910.146

**Confined Space** means a space that: (1) Is large enough and so configured that an employee can bodily enter and perform assigned work; and (2) Has limited or restricted means for entry or exit (for example, tanks, vessels, silos, storage bins, hoppers, vaults, and pits are spaces that may have limited means of entry); and (3) Is not designated for continuous employee occupancy.

**Permit-Required Confined Space (permit space)** means a confined space that has one or more of the following characteristics: (1) Contains or has a potential to contain a hazardous atmosphere; (2) Contains a material that has

the potential for engulfing an entrant; (3) Has an internal configuration such that an entrant could be trapped or asphyxiated by inwardly converging walls or by a floor which slopes downward and tapers to a smaller cross-section; or (4) Contains any other recognized serious safety or health hazard. Some states have individual laws concerning Confined Space. Check with your local and state regulations.

**NOTE: A permit required confined space situation is concrete removal from the drum.**

Always follow the lockout/tagout procedure for the vehicle/mixer system to prevent operation while performing service.

This procedure is meant to alert people and prevent drum rotation before performing service or maintenance activities.

Unexpected vehicle start-up and drum rotation will cause injury, use lockout/tagout procedures to prevent vehicle start-up.

Order a “Lockout Procedure Kit” (P/N 0002024) from the McNeilus Parts Department at 888-686-7278 or [www.streetsmartparts.com](http://www.streetsmartparts.com). This kit includes:

- (1) Drum Turnbuckle Wedge Assembly with 1-1/2” (38 mm) Wedges (P/N 0002025)
- (2) 12” x 18” (305 mm x 457 mm) Magnetic Danger Signs (P/N 0215074)
- (1) Danger Lockout Tag 2-1/4” x 4” (57 mm x 101 mm) (P/N 1171742)
- (4) 8-1/2” x 6” (215 mm x 152 mm) Vinyl Warning Decals (P/N 1171741)
- (1) Aluminium Lockout Hasp for 6 Padlocks Instructions

(P/N 1171743)

(2) Caution Man in Drum Decal (P/N 1171740)

In addition, your Maintenance Department will need to provide a personalized padlock for each person who is working on the Mixer.

### 1.1.2 Applying the Lockout/Tagout Procedure

1. Before any personnel can perform mixer drum service or maintenance, the employee or supervisor must inform the driver that his/her vehicle/mixer system is going to be “Locked Out,” and that he/she must not attempt to restart it until notified that it is safe to do so.
2. Position the truck on a firm, level surface. Place the transmission in PARK or NEUTRAL, and engage the park brake. Allow the engine to run at idle. (Refer to the Operator’s Manual supplied by the chassis supplier for all parking procedures.)
3. Place wheel chocks or blocks in front of and behind the truck’s front wheels.
4. Position the drum hatch (Figure 1, Item 1) so the hatch is on the driver’s side to perform service and maintenance.
  - Control the drum speed by manipulating the drum control lever in the cab, or the control lever on the drum control lever at the rear of the truck.
5. Make sure that the mixer drum warning decals (Figure 1, Item 2) are clean, readable, and properly positioned. Replace any damaged or unreadable decals immediately.

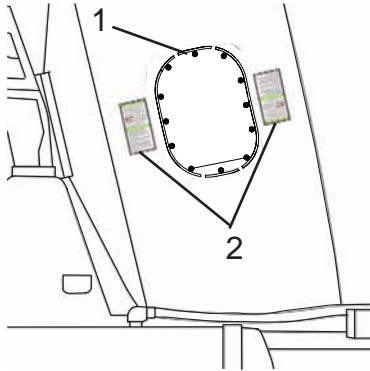

Figure 1

**NOTE**

**Shutting off the truck engine will stop mixer drum rotation.**

6. Engage the park brake and stop the chassis engine. (Refer to the Operator Manual supplied by the chassis supplier for all shut-down procedures.)
7. Before entering the mixer drum or performing service, the service/maintenance person must:
  - a. Shut off the truck engine.
  - b. Carry all ignition keys in his/her pocket.
  - c. Tag steering wheel using a nonreusable fastener.

8. Roll up all cab windows and lock all doors.
9. Place magnetic “DANGER” signs (Figure 2, Item 1) on both doors: “Man working on drum. Do not start Mixer or rotate drum. Serious personal injury or death can occur.”

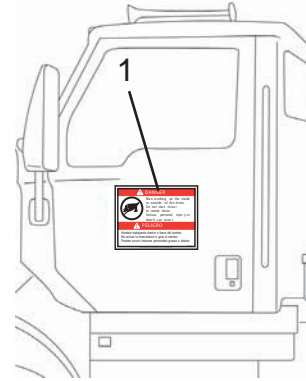

Figure 2

**⚠ WARNING**

**If performing service in or on the drum, the dual turnbuckle wedge assembly (and additional blocking as needed) must be used to prevent drum movement.**

**Failure to prevent drum movement might result in death or serious personal injury.**

**CAUTION**

Concrete build-up and removal of that concrete with pounding or the use of hydraulic tools might cause the drum to slip over the turnbuckle wedge. To help prevent this, additional blocking of the drum may be required.

10. Place the dual turnbuckle wedge assembly base (Figure 3, Item 1) on the rear pedestal. Make sure the wedge assembly base has a flat, clean surface. Extend the turnbuckles (Figure 3, Item 2) so the wedges are firmly in place between the drum roller track and rollers. Evenly snug up the turnbuckles one turn or more as needed to prevent possible drum rotation.
11. Tighten the turnbuckle jam nuts (Figure 3, Item 3) to secure the wedges in place.
12. Place operating equipment at its lowest potential energy position to prevent free fall.
13. Install blocking devices to prevent any raised device from falling.
14. If maintenance is needed on the hydraulic or pneumatic systems, after blocking devices are installed, relieve stored hydraulic or pneumatic pressure.

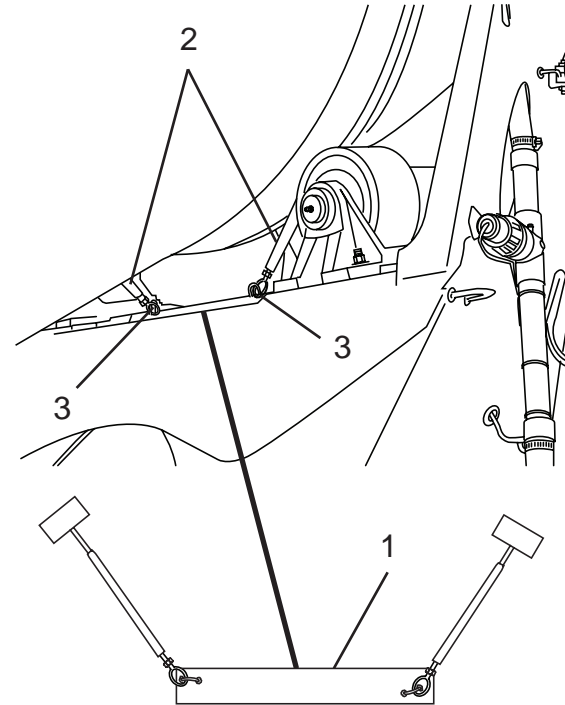

Figure 3

**1.1.3 Removing the Lockout/Tagout Procedure**

1. Loosen the turnbuckle jam nuts (Figure 4, Item 1).
2. Rotate the turnbuckles (Figure 4, Item 2) to retract the wedges from the drum roller track and rollers.
3. Remove the dual turnbuckle wedge assembly (Figure 4, Item 3) and any blocking from the rear pedestal.

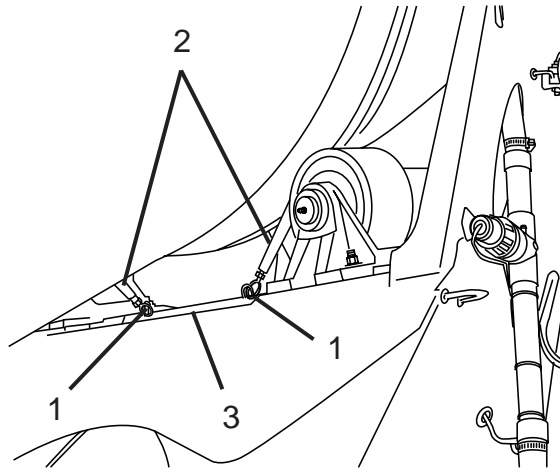

Figure 4

4. Remove magnetic “DANGER” signs (Figure 5, Item 1) from both doors.
5. Unlock cab doors.
6. Remove and discard the steering wheel fastener.

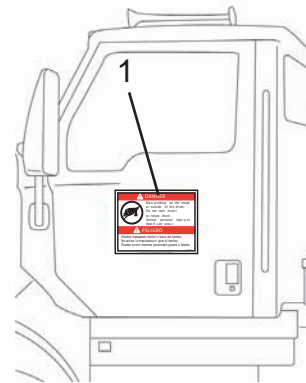

Figure 5

7. Remove all tools and other foreign objects from the area.
8. Check to make sure all mixer components (chutes, ladders, hoses, etc.) are properly stowed.
9. Inspect the area around the mixer system to make sure all people are clear before starting the Mixer.
10. Remove the wheel chocks or blocks from the front wheels before moving the truck.

## 1.1.4 Restoring Equipment to Normal Production Operations

1. After the servicing and/or maintenance is complete and the vehicle is ready for normal operations, check the area around the vehicle to ensure that no one is exposed.
2. After all tools have been removed from the vehicle, guards have been reinstalled and employees are in the clear, the employee who applied the LOCKOUT/TAGOUT device(s) will remove the device(s).
3. Notify all affected employees that the vehicle is being put in operation. Operate the energy-isolating devices to restore energy to the vehicle.

## 1.2 Battery Cable Disconnect

If the Mixer is not equipped with a battery disconnect switch, disconnect the negative (black) battery cable first, then disconnect the positive (red) cable.

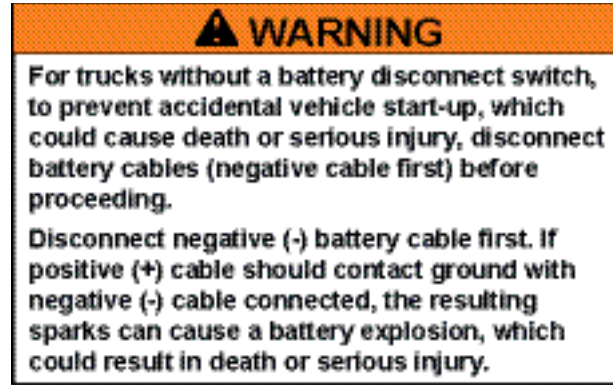

## 1.3 Safety Equipment

Some McNeilus Mixer Trucks come equipped with a five pound fire extinguisher, which has a rating of B:C, and a reflective warning triangle kit containing three triangles.

The fire extinguisher may already be mounted to the Mixer, otherwise it is temporarily placed into the cab of your truck along with the reflective triangle kit.

If you are supplying your own fire extinguisher, it must comply with DOT FMCSA regulation 173.309 and 393.95 for rating and placement on the vehicle.

You are responsible for permanent mounting of this equipment. The fire extinguisher is required to be securely mounted to prevent sliding, rolling, or vertical movement. The placement and mounting location of the reflective triangles are at your discretion.

## 1.4 Reporting Safety Defects

If you believe that your vehicle has a defect which could cause a crash or could cause injury or death, you should immediately inform the National Highway Traffic Safety Administration (NHTSA) in addition to notifying McNeilus Truck and Manufacturing, Inc., and the chassis manufacturer.

If NHTSA receives similar complaints, it may open an investigation, and if it finds that a safety defect exists in a group of vehicles, it may order a recall and remedy campaign. However, NHTSA cannot become involved in individual problems between you, your dealer, McNeilus Truck and Manufacturing, Inc., or the chassis manufacturer.

To contact NHTSA, you may call the Vehicle Safety Hotline toll-free at 1-888-327-4236 (TTY: 1-800-424-9153); go to <http://www.safercar.gov>; or write to: Administrator, NHTSA, 400 Seventh Street, SW., Washington, DC 20590. You can also obtain other information about motor vehicle safety from <http://www.safercar.gov>.

## 2.0 Product Safety Information

Safety notices are one of the primary ways to call your attention to potential hazards.



**THIS SAFETY SYMBOL INDICATES IMPORTANT SAFETY MESSAGES IN THIS MANUAL.**

**WHEN YOU SEE THIS SYMBOL, CAREFULLY READ THE MESSAGE THAT FOLLOWS.**

**BE ALERT TO THE POSSIBILITY OF PERSONAL INJURY OR DEATH.**

The following safety notices are used throughout this manual.

### **DANGER**

**Danger indicates an imminently hazardous situation which, if not avoided, will result in death or serious injury. Danger is used in the most extreme situations.**

### **WARNING**

**Warning indicates a potentially hazardous situation which, if not avoided, could result in serious injury or death.**

### **CAUTION**

**Caution indicates a situation that might result in property damage.**

### **SAFETY NOTICE**

### **OPERATOR'S INSTRUCTION**

The signal words of DANGER, WARNING, and CAUTION have specific meanings to alert you to the relative level of hazard.

Take the safety warnings seriously. If you do not understand them or have questions about them, call McNeilus Truck and Manufacturing, Inc.

## 2.1 Use Proper Safety Equipment

Always wear proper safety equipment/clothing while operating the Mixer.

Proper safety equipment includes:

- Hard Hat
- Safety Glasses or Goggles
- Snug-Fitting, Full-Covering Clothes
- Shirt with Tight-Fitting Long Sleeves (always keep shirt tails tucked in)
- Long Pants without Cuffs (Cuffs can be tripped over. Cuffs may also catch concrete)
- Steel-Toed Shoes or Boots
- Rubber Boots (if standing in concrete is required)
- Lime-Resistant Gloves
- Rubber Gloves (during clean-out)
- Hearing Protection
- Breathing Mask (if working in an area where cement dust is present)
- Breathing Apparatus and Ventilation Fan (if working in a Confined Space - see OSHA 1910.146)

Follow these guidelines to reduce risks of injury:

- Avoid wearing clothing that has long strings, fringes, or ties that can become caught in equipment
- Never wear jewelry (rings, necklaces, bracelets, wrist watches, etc.). These can become snagged on equipment or, if they come in contact with electrical circuits, can present a shock or burn hazard.
- Tie up long hair to prevent it from becoming caught in moving parts
- In cold weather, avoid wearing loose-fitting clothing. It is better to wear layers of clothing under a pair of snug-coveralls than a large, loose-fitting jacket or parka
- Keep work clothing clean and in good repair
- Keep the soles of your work boots clean and in good condition for traction when climbing on and off the vehicle/mixer system

## 3.0 Safety Information

Read, understand, and follow the safety guidelines and heed dangers and warnings listed below and contained in this manual as well as on the Mixer itself to promote reliable operation and prevent serious personal injury.

Contact McNeilus Truck and Manufacturing, Inc. if you require assistance or have questions.

## 3.1 Safety

### **WARNING**

**Anytime you are working on this equipment or its related systems, you must do the following:**

- 1. Inform the truck driver that the equipment is going to be repaired and locked out and that he must not attempt to start the truck.**
- 2. Follow all OSHA and Mixer lockout procedures. Remove the keys from the truck's ignition.**
- 3. Place magnetic signs on both doors of the truck which read "CAUTION - MAN WORKING ON MIXER - DO NOT START ENGINE."**
- 4. Lockout supplies are available from McNeilus Truck and Manufacturing, Inc.**

**READ, UNDERSTAND, AND FOLLOW THE SAFETY GUIDELINES, DANGERS, AND WARNINGS LISTED BELOW AND CONTAINED IN THIS MANUAL TO PROMOTE RELIABLE OPERATION AND PREVENT SERIOUS PERSONAL INJURY.**

**⚠ WARNING**

All owners and supervisors should make sure all drivers, operators, and maintenance personnel have read and thoroughly understand the decals affixed to this Mixer as well as the safety information and instructions in the McNeilus Operator's Manual. Owners and supervisors must read and understand the NRMCA manual.

**SAFETY NOTICE**

If chassis is equipped with a battery shut-off switch, it must be turned off anytime the equipment is parked overnight, in a shop, or out of service for any extended period of time. Failure to do so may result in a fire and personal injury or property damage.

**SAFETY NOTICE**

Immediately replace safety decals if damaged, unreadable, or missing. Contact McNeilus Truck and Manufacturing, Inc. at 888-686-7278 for no-charge replacement decals when required. Failure to replace decals may result in serious personal injury or death.

**⚠ WARNING**

This product may contain materials with chemicals or byproducts of chemical processes known in the State of California to cause cancer or birth defects or other reproductive harm (California Proposition 65).

## 3.2 Cab Operation

### DANGER

If the Mixer comes into contact or close proximity with a power line or there is any arcing, stay in the truck cab and keep away from the metal parts of the unit. Do not let anyone come close to the truck. Do not attempt to jump clear of the truck. Stay in the cab. The power company must disconnect the power before you can safely leave the cab.

Minimum clearance from power lines:

50,000 Volts or Less	4 Feet
50,000 + Volts	10 Feet
345,000 - 750,000 Volts	16 Feet

Know the clearance of overhead obstructions. Never drive the Mixer under any overhead obstruction without knowing the clearance height. If unit has a flip-up hopper, be sure hopper is in the lowered position. Failure to do so may result in damage to the Mixer body or truck, and may result in serious personal injury or death.

### DANGER

Never back up without taking every precaution to be sure the rear is clear. Check behind truck before backing up. Watch mirrors for activity. Never back up the Mixer unless and until you are completely sure it is safe. Use a spotter/observer and/or get out and check yourself to ensure it is safe to do so.

### WARNING

The operator and anyone working in the area of the Mixer should understand the meaning of all audible alarms and warning lights.

Failure to comply may result in serious injury or death.

**⚠ WARNING**

Thoroughly understand the controls before operating the Mixer. Be sure everyone is clear of the area around the truck before operating the Mixer. Remain attentive at all times when operating the controls.

**⚠ WARNING**

No passenger is allowed in the cab unless a manufacturer's approved passenger seat and seat belt are provided. Serious injury or death can result.

**⚠ WARNING**

The Mixer and the chassis must not be overloaded. Gross Vehicle Weights must not exceed the Manufacturer's gross vehicle weight of this vehicle. Gross Vehicle Weights must meet Federal, State, and Local laws.

**⚠ WARNING**

Never drive the truck with the water tank pressurized.

Serious personal injury or death may occur.

**⚠ WARNING**

Use slower speeds when going around curves or corners. You are carrying a high center of gravity load.

**⚠ WARNING**

At the job site, use the lowest transmission gear and proceed at low speed, 3 mph (4.8 km/h) maximum, to the discharge area.

**⚠ WARNING**

Optional air chute lock is intended for use only on the job site. The manual chute lock should always be engaged during transport. Excessive wear or injury may result due to improper usage.

### 3.3 Outside Operation

#### WARNING

##### IMPORTANT ALUMINUM AND STEEL WATER TANK INFORMATION.

1. Inspect water tank on a daily basis for any damage including, but not limited to, dents, gouges in metal, or leaks.
2. Do not weld on or repair water tank. Instead, replace water tank with a new OEM water tank.
3. Never pressure test an empty water tank. Only pressure test a full water tank.
4. Never remove pressure regulator or pressure safety valve from tank.
  - If regulator or safety valve is defective, it must be replaced before Mixer is put into service.
5. Do not pressurize water tank beyond its working pressure.
  - If pressure exceeds the working pressure, immediately depressurize water tank and replace pressure regulator and pressure safety valve.

#### WARNING

##### CONTINUED

6. Never drive the truck with the water tank pressurized.
  - Depressurize water tank prior to transit to or from job site.
  - Water tank should be pressurized only when being used.
7. Never modify water tank in any way.
8. Immediately replace safety decals with McNeilus decals if decals are missing or difficult to read.
9. Refer to the McNeilus Operator's Manual or contact McNeilus at 1-888-686-7278 if you have questions or require assistance.

#### WARNING

**NEVER** drink the water from a water tank. The water tank may contain residue from chemicals used to modify concrete properties. Drinking the water from a tank may cause serious internal injury or death.

**⚠ WARNING**

Never pressurize water tank in excess of 55 psi (380 kPa). If pressure exceeds 55 psi (380 kPa), depressurize the water tank immediately and adjust or replace the air regulator valve.

Serious personal injury or death may occur.

**⚠ WARNING**

Never pressurize an empty water tank.

Serious personal injury or death may occur.

**⚠ WARNING**

Use the three-point contact method (either two hands and one foot, or two feet and one hand on the ladder at all times) when climbing the ladder. Always face the ladder when climbing up or down. Serious personal injury may result due to a fall.

**⚠ WARNING**

Do not climb on ladders or ride on platforms (if equipped with either) while the truck is in motion or when ladders or platforms are wet and slippery. Serious personal injury may result due to a fall.

**⚠ WARNING**

Do not cross or stand behind vehicle while it is backing up.

Failure to heed these instructions/warnings may result in serious personal injury or death.

**⚠ WARNING**

Do not wear watches, rings, and jewelry while working with electrical and mechanical equipment. These items can be hazardous and can cause serious and painful injuries if they come into contact with electrical wires, moving parts, or hydraulic equipment.

**⚠ WARNING**

Always keep hands and feet clear of the Mixer drum, revolving parts, and moving parts while checking load or washing down the Mixer.

**⚠ WARNING**

Always keep clear of pinch and crush points. Failure to heed these instructions/warnings may result in serious personal injury or death.

**⚠ WARNING**

The Mixer must not be overloaded. Load pressures must match the load to be transported.

**⚠ WARNING**

All personnel must stand clear of the chutes during raising and lowering, and when chutes are loaded with concrete. Position chutes while they are not loaded. A loaded chute falling on a person may cause serious injury. All chutes must be handled with great care to avoid injury. Do not stand on the chutes.

**⚠ WARNING**

Do not let persons, other than the driver, handle the chutes, unfold the foldover, and/or remove extension, or stow and secure the extensions for transit. Keep hands away from chute hardware where the chutes connect. Never stand in the path of the chute as it is being unfolded or while in use. Failure to follow the warnings concerning chute safety may result in serious injury.

**⚠ WARNING**

Wear proper Personal Protective Equipment (PPE) such as hard hats, safety glasses, gloves, safety shoes, and snug-fitting sturdy long-sleeve shirt and long pants when operating or maintaining the Mixer.

Reflective clothing is recommended for drivers and employees.

Serious personal injury or death can result without proper PPE.

**⚠ CAUTION**

Do not use the water tank as a step.

Using the water tank as a step may result in personal injury or damage to equipment.

**⚠ CAUTION**

Do not use more chute extensions than are specified for your Mixer. Never exceed three chute extensions.

Do not use any other type or style of chute extensions, other than ones designed for use with your Mixer.

Using additional chute extensions, or the improper type of chute extensions, may result in personal injury or damage to equipment.

### 3.4 Maintenance

**⚠ DANGER**

LOCKOUT/TAGOUT procedures must be followed when working on this equipment including, but not limited to, cylinders being changed or maintained. Failure to heed these instructions/warnings can result in serious personal injury or death.

** DANGER**

Do not attempt to use extraneous sources of power or extraneous machines to overcome a malfunctioning system. Contact McNeilus Truck and Manufacturing, Inc., if you are unsure how to proceed.

Do not override with overhead cranes, forklifts, jacks, etc., or jury-rig systems or equipment that may be malfunctioning.

Failure to heed the foregoing instructions/warnings can result in serious personal injury or death.

** DANGER**

Auxiliary pusher or tag axles must be supported with jack stands, blocks, or similar devices while being serviced or maintained to prevent serious personal injury or death if auxiliary axle drops unexpectedly. Failure to do so may result in serious personal injury or death.

** WARNING**

Never enter under the chassis unless the Mixer is in the LOCKOUT mode. Remember to follow the LOCKOUT procedures when working under the truck.

Failure to heed may result in serious personal injury or death.

** WARNING**

When working on the Mixer, the wheels must be blocked, the parking brake on, LOCKOUT procedure in effect, and the keys out of the truck's ignition.

Failure to heed may result in serious personal injury or death.

**⚠ WARNING**

Daily inspection should be performed on the Mixer. This includes proper operation of the controls, hydraulics, lock-out systems, electrical systems, and lighting system, including turn signals, back-up alarm, brake lights, clearance lights, head lamps, tail lamps, safety equipment, and work lights. The truck's air system must operate properly and have no leaks. Water and moisture should be drained from the truck's air system daily. Failure to heed may result in serious personal injury or death.

**⚠ WARNING**

The Mixer must not be modified in any way without authorization from McNeilus Truck and Manufacturing, Inc. Modifications may not comply with safety standards, including ANSI safety standards, and may result in serious personal injury.

**⚠ WARNING**

Exceeding axle gross weight will result in premature brake wear and reduced brake performance. Inspect and adjust chassis brake as per the chassis manufacturer's recommendations. Failure to inspect and adjust brakes may result in serious personal injury or death.

**⚠ WARNING**

Main, foldover, and extension chutes must be inspected on a daily basis for damage, excessive wear, proper hardware fit, twist, and overall condition to determine that they are safe to use. Unsafe chutes must be replaced with new chutes.

** WARNING**

Do not repair or weld on steel or aluminum water tanks. Inspect the water tank for rust and corrosion every 30 days. Inspect the water tank under the straps, on the exterior and interior by removing the flopper. If any rust or corrosion is found, replace the water tank with an OEM water tank from McNeilus. Contact McNeilus Truck and Manufacturing, Inc. with questions. Failure to maintain water tanks may result in serious personal injury or death.

**3.5 Hydraulics**** WARNING**

Hydraulic hoses and tubing must be inspected on a daily basis for leaks, cuts, abrasions, damage, aging, improper clearance, and along the frame for hidden damage. If you find hoses with any such adverse conditions or damage, they must be replaced before the vehicle is returned to service! Failure to properly inspect and maintain your vehicle may result in serious personal injury or death.

** WARNING**

Inspect the hydraulic reservoir on a daily basis for leaks, cracks, damage, or improper clearance. If you find any such adverse conditions or damage, it must be repaired before the Mixer is returned to service! Failure to properly inspect and maintain your Mixer may result in serious personal injury or death.

**⚠ WARNING**

Never operate the hydraulic system if a leak is present. Operating the Mixer with a hydraulic system leak may result in serious personal injury or death.

**⚠ WARNING**

Hydraulic systems are hot. **DO NOT TOUCH!** Serious personal injury or death may result from hot oil. When you have completed working on the hydraulic systems, thoroughly clean any spilled oil from the equipment. Do not spill any hydraulic fluid on the ground. Clean any hydraulic fluid from your skin as soon as you have completed your maintenance and repairs. Dispose of used oil and filters as required by law.

**⚠ WARNING**

Hydraulic systems operate under high pressure. Only qualified, experienced people properly trained in hydraulic system maintenance should attempt repairs or troubleshoot hydraulic systems. Use the proper tools and equipment when servicing the hydraulic system. Failure to comply can cause serious injury. Please contact McNeilus Truck and Manufacturing, Inc. at 888-686-7278 if you require assistance.

**⚠ WARNING**

Correct hoses, fittings, and adapters with the correct SAE rating must be used when replacing hoses to prevent possible serious injury. Always replace hoses, fittings, and adapters with replacements that have a proper, suitable working pressure rating. Replacement hoses must be of correct length and must comply with the hose manufacturer's installation guidelines and recommendations. Hydraulic hoses have the SAE ratings marked on the hose to assist you in selecting the correct hose. Any replacement hydraulic hoses and fittings assemblies must be supplied by the same manufacturer. As an example: Brand "A" hose and brand "B" fitting will not normally be compatible. No "twist" is allowed in the hydraulic hoses. "Twist" may result in premature hose failure.

**⚠ WARNING**

Any hydraulic tubing which is replaced must conform to SAE J1065 specifications. If incorrect hydraulic tubing is installed, the hydraulic system may fail, causing serious injury. Damaged or leaking tubing must be replaced before the Mixer is returned to service. For best results, always use genuine McNeilus replacement parts.

**⚠ WARNING**

Do not heat hydraulic tubing. The carbon content of this steel tube is such that if heated for bending, and either water or air is quenched, the tubing may lose its ductility and thereby be subject to failure under high pressure or hydraulic shock conditions. Serious injury can result. Damaged or leaking tubing must be replaced before the Mixer is returned to service. Please contact McNeilus Truck and Manufacturing, Inc. at 888-686-7278 if you require assistance or have questions.

**⚠ WARNING**

Hydraulic components can be heavy. Use caution while lifting these components. Serious personal injury can be avoided with proper handling of the components.

**⚠ WARNING**

Use the proper tools and equipment when servicing the hydraulic system. Use only the McNeilus charging kit when recharging the accumulator.

**⚠ WARNING**

Never remove hydraulic pipes/tubing, fittings, and adapters until all pressure has been relieved from the hydraulic system.

**⚠ WARNING**

All hydraulic pressures must be relieved from the hydraulic system prior to removing any components from the system to prevent oil from spraying or functions and systems from failing.

**⚠ WARNING**

When performing hydraulic test procedures, use the proper hydraulic gauges. Installing an incorrect test gauge could result in serious injury or death if the gauge fails. Use properly rated hydraulic hoses with adequate length to allow the test gauge to be used far enough away from moving parts and functions.

**⚠ WARNING**

Increasing hydraulic pressure beyond the recommendations may result in serious damage to the Mixer or serious personal injury. If you have questions concerning hydraulic pressures or testing procedures, please contact McNeilus Truck and Manufacturing, Inc. at 888-686-7278 before attempting the test procedures or making adjustments.

**⚠ WARNING**

When using the emergency jumper procedure to rotate the drum on a disabled Mixer, the following must be observed: Before removing the hydraulic motor or hoses from the Mixer drive on both the operating and disabled Mixer, be sure the drum has been allowed to turn freely so that it is balanced with no forces transmitted to the hydraulic motor.

**3.6 Electrical****⚠ WARNING**

Electrical wiring, battery wiring, and electrical cable must be inspected on a daily basis for cuts, abrasions, damage, aging, improper clearance, and along the frame for hidden damage.

If you find electrical wiring or electrical cable with any such adverse conditions or damage, it must be replaced with electrical wiring or cable of equivalent specifications before the Mixer is returned to service!

Failure to properly inspect and maintain your Mixer may result in a serious personal injury. Contact McNeilus Truck and Manufacturing, Inc. if in need of further information.

**3.7 Chute Extensions****⚠ DANGER**

Do not repair metal or composite chute extensions.  
Serious personal injury or death could occur.

** DANGER**

Do not over-load chute extensions. Maximum load capacity of 400 lbs. per chute extension.

** DANGER**

Composite chute extensions are flammable. Do not expose to an open flame or a temperature exceeding 220°F (104°C). Burning chute extensions produce toxic smoke/fumes during combustion. Serious personal injury or death could occur.

** CAUTION**

Chute extensions must be secured on the truck before leaving the job site. Failure to comply may result in damage to the equipment.

** DANGER**

Inspect chute extensions prior to each use. Never use a damaged chute extension or a chute extension that has been driven over. Replace damaged chute extensions immediately.

** DANGER**

Never stand on a chute or chute extensions. Do not use the chute as a crane to pull or transport objects.

** CAUTION**

Do not use more than three chute extensions. Do not combine the use of metal and composite chute extensions during operational use. Failure to comply could cause damage to the equipment.

** CAUTION**

Never clean chute extensions by striking or chiseling.

## 4.0 Safety Decals

The following safety decals are found on your concrete Mixer. They warn of hazards related to the use of this equipment. Read and understand all safety decals before operating this equipment. All safety decals should be present and clearly readable at all times. If any safety decals on the equipment are not clearly readable, contact McNeilus parts and service at 888-686-7278 or [www.streetsmartparts.com](http://www.streetsmartparts.com) for replacements free of charge. Use only McNeilus replacement decals.

### NOTE

**Depending on the Mixer configuration and optional equipment, the actual location of decals and/or placards may vary slightly from the examples shown.**

The table below contains part numbers for the individual safety decals. See the Figures in this section for decal identification of each safety decal.

### NOTE

**Specifications, appearance, and part numbers for safety decals are subject to change without notice.**

No.	Part Number	Qty.	Description
1	0214603	4	Warning: Operator should not stand beneath or pull chutes over himself during concrete discharge.
2	1321144	2	Warning: Crush Hazard. Moving drum can crush you against debouncer. <b>Standard (Steel) Drum</b>
4	0129700	2	McNeilus
5	0215072	2	Caution: Stay clear of rotating drum.
7	0215100	1	Operator's Instruction: Change oil after first 100 hours.
8	0214504	1	Operator's Instruction: Remove transit strap upon delivery. <b>Used for Mixer delivery only</b>
9	Not Available Separately. If needed, order part number 0214545.	1	DRUM MUST BE ROTATING AT ALL TIMES WHILE DELIVERING TRUCK. <b>Used for Mixer delivery only</b>
10	1138174	1	MIXER PENDANT INSTRUCTIONS CARD <b>Used for Mixer delivery only</b>
11	0155068	1	When in transit, rotate drum. <b>Used for Mixer delivery only</b>

No.	Part Number	Qty.	Description
12	1240555	1	Notice: CHUTE IS NOT TO BE OPERATED UNTIL AFTER DELIVERY OF TRUCK.
13	0215099	1	Danger: Avoid turnover. You are hauling a high center of gravity fluid load!
14	0214515	1	Danger: No passenger is allowed in the cab unless a manufacturer's approved passenger seat and seat belt are provided.
15	0215063	2	Warning: Never place tools, hoses, hands, arms, or any part of the body or clothing in the vicinity of fins, rollers, drum, or any other part of the mixer while it is in motion.
16	9083.601930	2	Caution: Welding on this structure will result in damage to load cell and indicator.
17	0214672	2	Operator's Instruction: Engage manual chute lock when in transit.
18	0215097	1	Safety Notice: Fresh Concrete.
19	0215060	3	Caution: Do not exceed three (3) extension chutes or any other type/style of chute.

No.	Part Number	Qty.	Description
20	0115118	1	Caution: Before unfolding chute be sure people on the other side are clear.
21	1130173	2	Warning: Never place tools, hoses, hands, arms, or any part of the body or clothing in the vicinity of Power Chute Swing mechanism. <b>Hydraulic chute swing option only</b>
22	0214502	1	Operator's Instruction: PTO shaft, universal joints and spline must be lubricated weekly.
23	0215059	1	Danger: Do not enter under chassis unless engine or power units are stopped, ignition keys removed, and lockout procedures are followed.
24	0214512	2	Warning: Do not use as a step.
25	0214671	1	Danger: DO NOT use as a tow bar under any circumstances.
26	0215064	2	Warning: Never place tools, hoses, hands, arms, or any part of the body or clothing in the vicinity of fins, rollers, drum or any other part of the mixer while it is in motion.

No.	Part Number	Qty.	Description
27	0214724	2	Warning: Always position your hands with your fingers around the side (formed edge) of the chute. <b>Quantity of Decals Per Chute.</b>
28	1130172	8	Warning: Stay clear of chutes when Power Chute Swing is in operation. <b>Hydraulic chute swing option only</b>
29	1141691	1	Warning: Routine inspection and maintenance is required for all aluminum extension chutes. <b>Quantity of Decals Per Chute.</b>
30	0215023	1	Warning: DO NOT FILL the mixer drum with any amount of concrete that will cause the GVWR or GAWR of the truck (as shown on the certification label of the vehicle manufacturer) to be exceeded.
31	0115117	1	Operator's Instruction: DAILY CHECKLIST.
32	0215141	1	Operator's Instruction: McNeilus will not accept responsibility for damage to paint, hydraulic cylinders, or any indirect damage resulting from the use of acid based cleaners on this mixer.

No.	Part Number	Qty.	Description
33	0215119	1	Operator's Instruction: When in transit, rotate drum.
34	0614000	2	Operator's Instruction: Under no circumstances should you overload the mixer.
35	1394101	1	Danger: LOOK UP AND LIVE.
36	0115100	1	Caution: Oil temperatures may exceed 120°F.
37	0129702	1	Operator's Instruction: Hydraulic Oil and Filter Elements.
38	0129709	1	Danger: NEVER LEAN OR CLIMB OVER RAILING.
39	1138173	1	Warning: The hopper prop pin must be moved from stowed position to locked position when standing on upper ladder platform with the charge hopper raised.
40	0214667	1	Danger: Do not climb on ladder or stand on platform while truck is in motion.
41	0214666	1	Danger: Use extreme care and a three point stance when on ladder or platform.
43	0215123	2	Caution: KEEP HANDS AND BODY AWAY FROM PIVOT POSITION.

No.	Part Number	Qty.	Description
44	0215095	1	Safety Notice: Always secure fold over chute with safety chain.
45	1171741	3	Safety Notice: 1. BEFORE ENTERING DRUM, read and follow OSHA Regulations concerning entry and working in "CONFINED SPACE" OSHA 1910.146 and "LOCKOUT/TAGOUT" OSHA 1910.147.  <b>One decal inverted on drum hatch opening.</b>
46	0214500	1	Safety Notice: Do not operate or service this machine until you have read and understood the operation manual supplied with this equipment.
47	0215086	1	Warning: Do not drink the water.
48	0215058	1	Caution: Use care and a three point stance when climbing on ladder or platform, which may be slippery.
49	1326014	1	Mixer Hand Signals

No.	Part Number	Qty.	Description
50	1420547	1	Danger: Inspect water tank daily for damage including, but not limited to, dents, gouges in metal, or leaks.
51	1241178	1	Operator's Instruction: WATER PUMP.  <b>Used on trucks with pump water system only.</b>
52	1138175	1	This diagram shows the function of each of the valves on the pneumatic manifold.
53	1326487	1	Operator's Instruction: Drain coalescing filter bowl daily.
54	0214523	1	McNeilus GENUINE REPLACEMENT PARTS.
55	1139944	1	NOT A STEP
56	TMMB	1	This drum was manufactured by a member of the Truck Mixer Manufacturers Bureau.
58	0214618	1	Operator's Instruction: All circuit breakers and fuses to the cab control console must be in the off position before jump starting or charging the battery.

No.	Part Number	Qty.	Description
59	0214648	1	NO STEP
60	1420592	1	Danger: Do Not Modify or Remove Pressure Relief.
61	1496869	1	If Equipped with Single Cable. Secure extension chutes on chute rack.

## 4.1 Safety Decal and Placard Locations

### 4.1.1 Curb Side Views

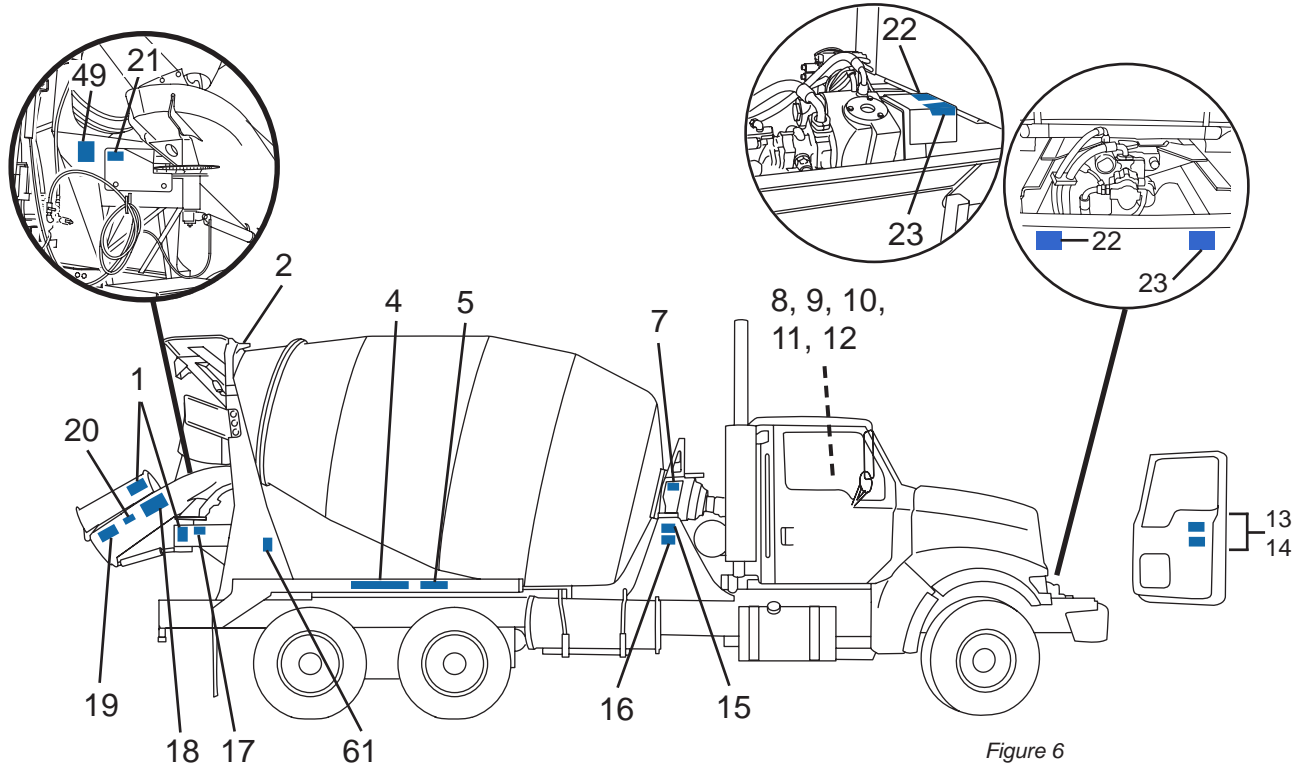

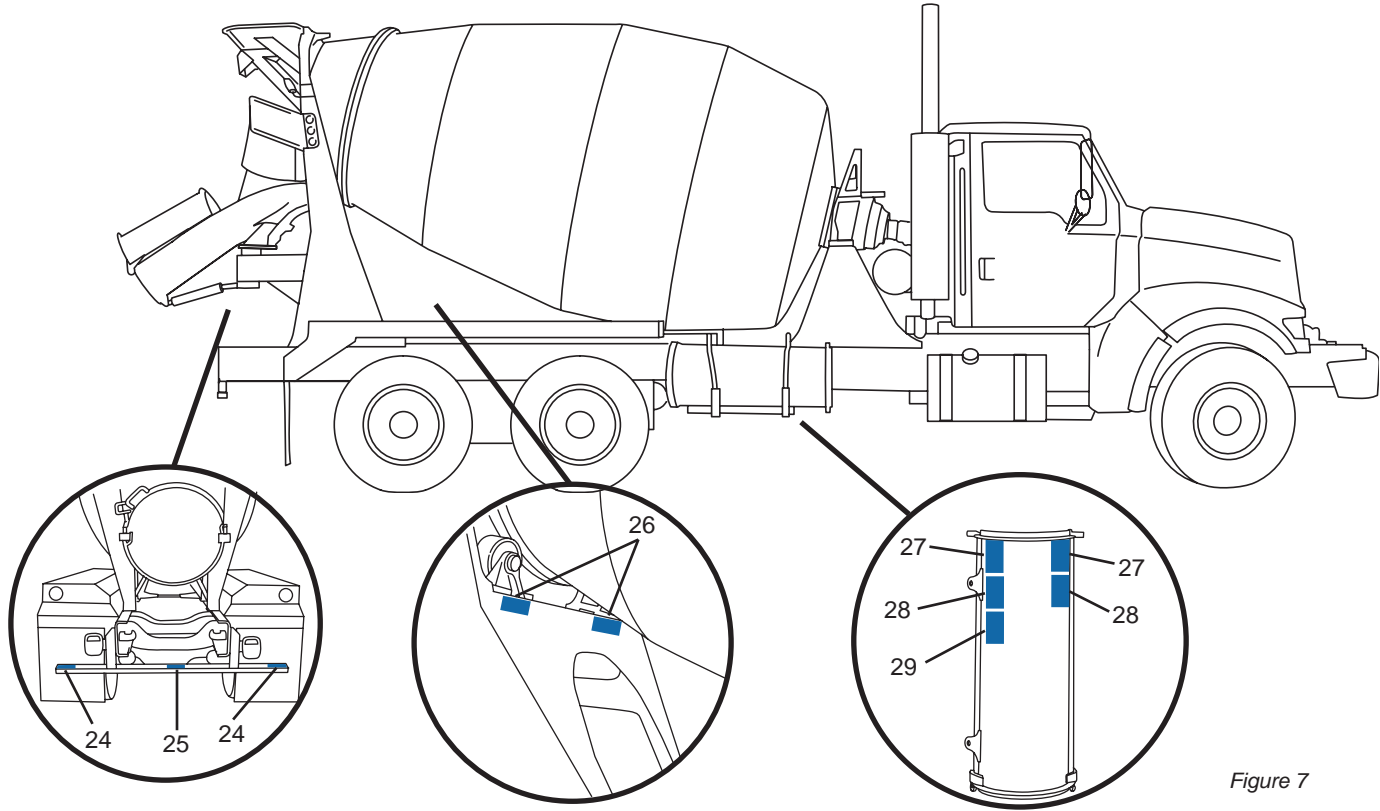

Figure 7

**4.1.2 Street Side Views**

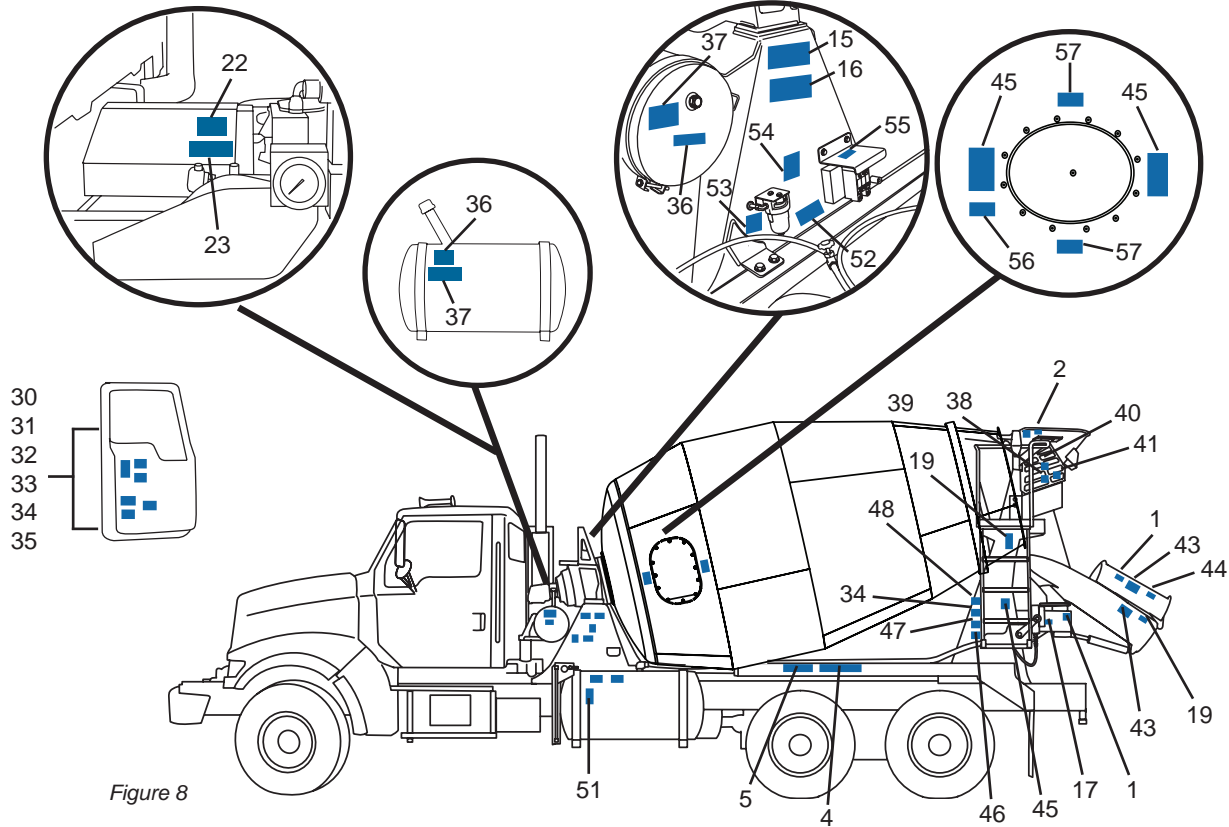

Figure 8

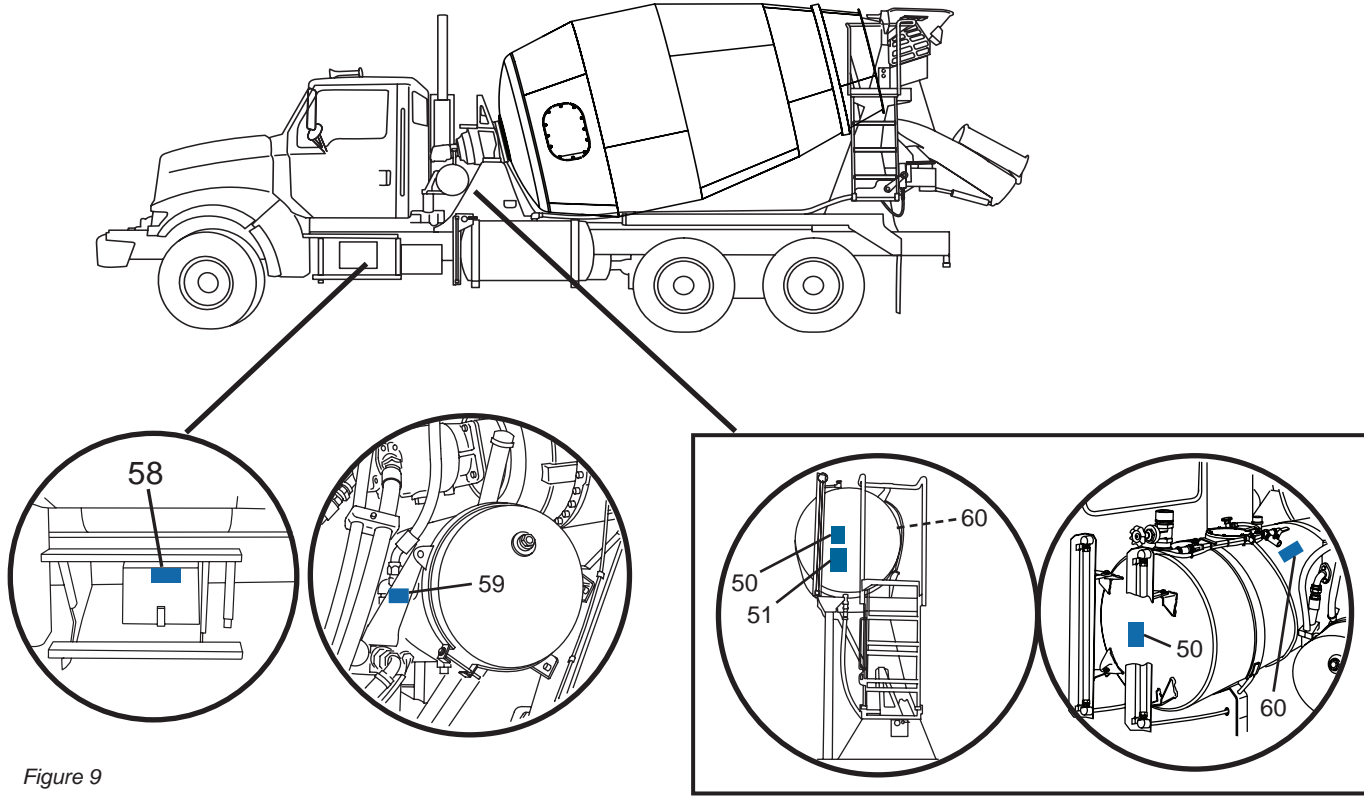
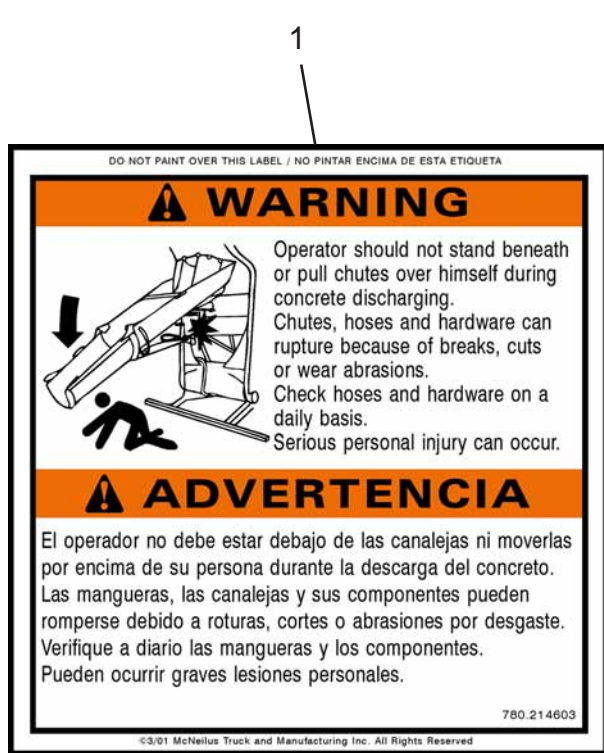

Figure 9

## 4.2 Safety Decal Identification



4



5

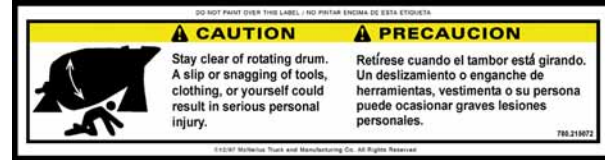

7

DO NOT PAINT OVER THIS LABEL / NO PINTAR ENCIMA DE ESTA ETIQUETA

**OPERATOR'S INSTRUCTION**

**Change oil after first 100 hours.  
Thereafter change every six months.  
Capacity: fill to check plug or site glass.  
Recommended lubricant: GL5 spec.  
85W-140**

**INSTRUCCIONES PARA EL OPERADOR**

**Cambie el aceite después de las primeras 100 horas.  
Después, cámbielo cada seis meses.  
Capacidad: Llénelo hasta la tapa o la ventana de la  
mirilla de aceite.  
Lubricante recomendado: GL5 spec. 85W-140**

780.215100

©3/01 McNeilus Truck and Manufacturing Inc. All Rights Reserved

8

DO NOT PAINT OVER THIS LABEL / NO PINTAR ENCIMA DE ESTA ETIQUETA

**OPERATOR'S INSTRUCTION**

**Remove transit strap upon delivery.  
Failure to do so will impede  
operation of pump.**

**INSTRUCCIONES PARA EL OPERADOR**

**Al recibir el equipo, retirar las bandas de seguridad  
para el embarque. Si no se hace impedirá el  
funcionamiento de la bomba.**

780.214504

©9/02 McNeilus Truck and Manufacturing Inc. All Rights Reserved

9

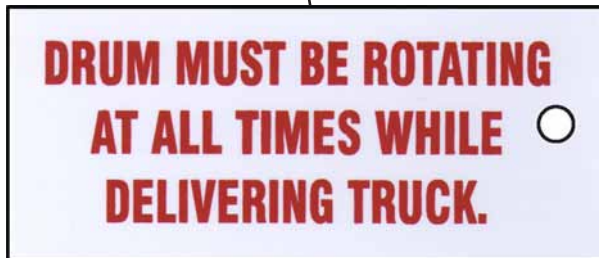

10

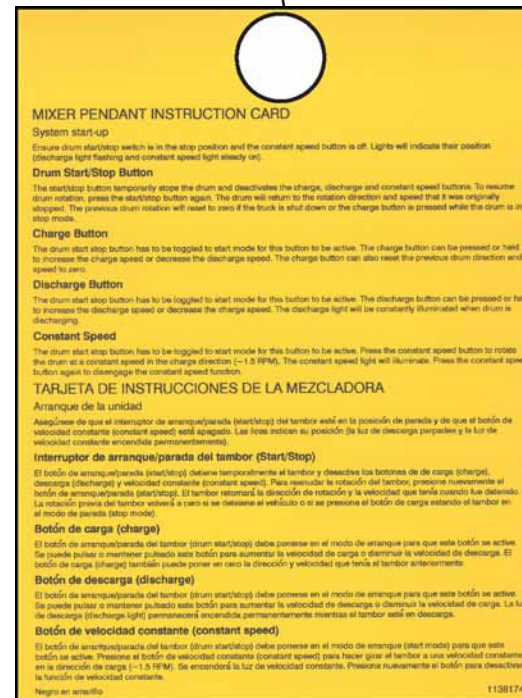



13

DO NOT PAINT OVER THIS LABEL / NO PINTAR ENCIMA DE ESTA ETIQUETA

**! DANGER**



**Avoid Turnover**  
**You are hauling a high center of gravity fluid load!**  
**Failure to do so can result in serious personal injury or death.**

**! PELIGRO**

Evite que se voltee el vehículo  
 ¡Usted está transportando una carga de fluido que tiene un centro de gravedad alto!  
 En caso contrario pueden ocurrir lesiones personales graves o fatales.

780.215099

©3/01 McNeilus Truck and Manufacturing Inc. All Rights Reserved

14

DO NOT PAINT OVER THIS LABEL / NO PINTAR ENCIMA DE ESTA ETIQUETA

**! DANGER**



**No Passenger is Allowed in the Cab**  
**Unless a Manufacturer's Approved Passenger Seat and Seat Belt are Provided.**  
**Serious personal injury or death can occur in the case of a sudden stop or vehicle accident.**

**! PELIGRO**

No se permite ningún pasajero dentro de la cabina salvo que se provea un asiento para pasajeros y un cinturón de seguridad aprobados por el fabricante.  
 Una frenada repentina o un accidente pueden ocasionar lesiones personales graves o fatales.

780.214515

©12/07 McNeilus Truck and Manufacturing Inc. All Rights Reserved

15



16



17

DO NOT PAINT OVER THIS LABEL / NO PINTAR ENCIMA DE ESTA ETIQUETA

**OPERATOR'S INSTRUCTION**

**Engage manual chute lock when in transit.**

**INSTRUCCIONES PARA EL OPERADOR**

Enganche el seguro de la canaleja manual cuando esté en tránsito.

780.214672

©12/97 McNeilus Truck and Manufacturing Co. All Rights Reserved

18

DO NOT PAINT OVER THIS LABEL / NO PINTAR ENCIMA DE ESTA ETIQUETA

**SAFETY NOTICE**

**Fresh Concrete**  
Can cause burns and eye injury!

- Avoid skin contact
- Wear protective clothing
- Wash exposed skin with water

If concrete gets into eyes, rinse immediately with water and obtain prompt medical attention.

**KEEP CHILDREN AWAY FROM FRESH CONCRETE**

**AVISO DE SEGURIDAD**

**Concreto Fresco**  
Puede causar quemaduras y lesiones a los ojos

- Utilice ropa adecuada
- Evite contacto con la piel
- Inmediatamente lave con agua la piel que haya sido expuesta

Si le cae concreto en los ojos, inmediatamente enjuague con agua y obtenga atención médica.

**MANTENGA A LOS NIÑOS ALEJADOS DEL CONCRETO FRESCO**

780.219097

©12/97 McNeilus Truck and Manufacturing Inc. All Rights Reserved

19

DO NOT PAINT OVER THIS LABEL / NO PINTAR ENCIMA DE ESTA ETIQUETA

**CAUTION**



Do not exceed three (3) extension chutes or any other type/style of chute. Serious personal injury can occur

**PRECAUCION**

No exceda más de tres (3) canalejas de extensión o cualquier otro tipo/estilo de canaleja. Pueden ocurrir graves lesiones personales.

780.215060

©12/97 McNeilus Truck and Manufacturing Co. All Rights Reserved

20

DO NOT PAINT OVER THIS LABEL / NO PINTAR ENCIMA DE ESTA ETIQUETA

**CAUTION**



Before unfolding chute be sure people on other side are clear. Keep hands away when folding or unfolding chute. Serious personal injury can occur.

**PRECAUCION**

Antes de desdoblar la canaleja, asegúrese de que no hay nadie en el otro lado. Retire las manos al doblar o desdoblar la canaleja. Puede ocurrir graves lesiones personales.

780.115118

©12/97 McNeilus Truck and Manufacturing Co. All Rights Reserved

21

DO NOT PAINT OVER THIS LABEL / NO PINTAR ENCIMA DE ESTA ETIQUETA

**⚠ WARNING**



Never place tools, hoses, hands, arms, or any part of the body or clothing in the vicinity of Power Chute Swing mechanism. A slip or snagging of tools, clothing, or yourself could result in serious personal injury.

**⚠ ADVERTENCIA**

Nunca coloque herramientas, mangueras, manos, brazos, ni ninguna otra parte del cuerpo o ropa en la cercanía del mecanismo del oscilador motorizado del vertedero. Si se resbalan o enganchan herramientas, ropa o usted mismo, se podría ocasionar una lesión personal grave.

1130173

©2/02 McNeilus Truck and Manufacturing Inc. All Rights Reserved

22

DO NOT PAINT OVER THIS LABEL / NO PINTAR ENCIMA DE ESTA ETIQUETA

**OPERATOR'S INSTRUCTION**

**PTO Shaft, Universal Joints and Splines must be lubricated weekly.**

**INSTRUCCIONES PARA EL OPERADOR**

La flecha del PTO, las juntas universales y la acanaladura deben lubricarse semanalmente.

780.214502

©3/01 McNeilus Truck and Manufacturing Inc. All Rights Reserved

23



24



25



26



27

DO NOT PAINT OVER THIS LABEL / NO PINTAR ENCIMA DE ESTA ETIQUETA

**⚠ WARNING**

Always position your hands with your fingers around the side (formed edge) of the chute. Failure to do so can cause serious personal injury.

Operator should not stand beneath or pull chutes over himself during concrete discharging. Chutes, hoses and hardware can rupture because of breaks, cuts or wear abrasions. Check hoses and hardware on a daily basis. Serious personal injury can occur.

Never hold the end of a chute. Serious personal injury can occur.



**⚠ ADVERTENCIA**

Siempre ponga sus manos con sus dedos situados a los lados exteriores del borde del canalón.

El operador no debe permanecer de pie debajo de las canaléjas ni moverlas por encima de su persona durante la descarga del concreto. Las mangueras, las canaléjas y sus componentes pueden romperse debido a roturas, cortes o abrasiones por desgaste. Verifique a diario las mangueras y los componentes. Pueden ocurrir graves lesiones personales.

Nunca sostenga el extremo final del canalón. Lesiones personales pueden ocurrir.

780.214724

© 2013 McNeilus Truck and Manufacturing Inc. All Rights Reserved

28

DO NOT PAINT OVER THIS LABEL / NO PINTAR ENCIMA DE ESTA ETIQUETA

**⚠ WARNING**



Stay clear of chutes when Power Chute Swing is in operation. Failure to do so could result in serious personal injury or property damage.

**⚠ ADVERTENCIA**

Permanezca alejado de los vertederos cuando el oscilador motorizado del vertedero esté en operación. Si no lo hace podría sufrir una lesión grave o daños materiales.

1130172

©2/02 McNeilus Truck and Manufacturing Inc. All Rights Reserved

29

DO NOT PAINT OVER THIS LABEL / NO PINTAR ENCIMA DE ESTA ETIQUETA

**⚠ WARNING**

Routine inspection and maintenance is required for all aluminum extension chutes. The list below contains the requirements:

Inspect aluminum chutes for any cracks. If a crack is found, discontinue using the chute immediately.

Do not attempt any repairs unless a duly certified and competent welder is available to perform the repair. Contact McNeilus Companies at 507-374-6321 if you need assistance.

Do not clean an aluminum chute using acid. Doing so will have adverse effects to the chute.

**⚠ ADVERTENCIA**

Se requiere la inspección y el mantenimiento de rutina de todos los canales de extensión de aluminio. A continuación se expone la lista de las tareas:

Inspeccione los canales de aluminio para ver si tienen grietas. Si encuentra una grieta, discontinúe inmediatamente el uso del canal.

No intente hacer reparaciones a menos que cuente con un soldador competente debidamente certificado para realizar la reparación. Si necesita asistencia, comuníquese con McNeilus Companies llamando al teléfono 507-374-6321.

No limpie los canales de aluminio con ácido. Si lo hace, afectará adversamente el canal.

1141091

©11/02 McNeilus Truck and Manufacturing Inc. All Rights Reserved

30

DO NOT PAINT OVER THIS LABEL / NO PINTAR ENCIMA DE ESTA ETIQUETA

**⚠ WARNING**



DO NOT FILL the mixer drum with any amount of concrete that will cause the GVWR or GAWR of the truck (as shown on the certification label of the vehicle manufacturer) to be exceeded. Exceeding the vehicle manufacturer's GVWR or GAWR certification limits or limits of this equipment can cause damage to the equipment or serious personal injury to the operator and others.

**⚠ ADVERTENCIA**

NO LLENE el tambor de la mezcladora con una cantidad de concreto que haga que la carga GVWR o GAWR del camión (como se muestra en la etiqueta de certificación del fabricante del vehículo) se exceda.

El exceder la limitación o limitaciones de la certificación de carga GVWR o GAWR para este equipo, provista por el fabricante del vehículo, puede dañar el equipo o causar serias lesiones personales al operador y a otras personas.

780.215023

©12/97 McNeilus Truck and Manufacturing Co. All Rights Reserved

31

DO NOT PAINT OVER THIS LABEL / NO PINTAR ENCIMA DE ESTA ETIQUETA

## OPERATOR'S INSTRUCTION

<p><b>DAILY CHECKLIST</b></p> <p><b>GREASE:</b> PTO shaft from pump to engine or transmission Drum rollers Rear control bars Cable control bars Main shaft pin</p> <p><b>CHECK BEFORE START UP:</b> Oil level in reservoir Inspect hoses for cuts, abrasions, and damage</p> <p><b>CHECK AFTER START UP:</b> Vacuum gauge in mixer below 10 Hydraulic meter for leaks Hydraulic pump for leaks PTO shaft doesn't have vibration Drum rollers for rotation Drum rollers both directions Inspect hoses for cuts, abrasions, and damage</p>	<p><b>CAUTION:</b> Start up in cold temperatures could cause damage to hydraulic system If oil doesn't flow vacuum gauge will read high on scale</p> <p><b>WEEKLY CHECK LIST:</b> Mixer mounting bolts secure Direct drive mounting bolts secure Water tank brackets secure PTO mounting bolts secure Pump mounting bolts secure Roller adjustment correct Direct drive lubrication full Chute filler reservoir full with chutes down</p>	<p><b>IMPORTANT FACTS:</b></p> <ol style="list-style-type: none"> <li>If oil vacuum gauge remains above 0 after warm up period of filler should be changed.</li> <li>While driving vehicle drum should be rotating to prevent drum roller damage</li> <li>Air pressure in water tank should not exceed 50 lbs. pressure</li> </ol>
--	---	--

## INSTRUCCIONES PARA EL OPERADOR

<p><b>LISTA DE VERIFICACION DIARIA:</b></p> <p><b>ENGRASAR:</b> La flecha del PTO de la bomba hacia el motor o la transmisión. Los rodillos del tambor. La caja de control de la cabina. El pin de la cadena principal.</p> <p><b>ANTES DE PONER EN MARCHA REVISAR:</b> El nivel del aceite en el depósito. Inspeccione las mangueras en busca de cortes, abrasiones y daño.</p> <p><b>DEPUÉS DE PONER EN MARCHA REVISAR:</b> Que el indicador de vacío está en menos de 10. Si el motor hidráulico gotea. Si la bomba hidráulica gotea. Que la varilla PTO no tenga vibración. Que los rodillos del tambor roten. Que el tambor rote en ambas direcciones. Inspeccione las mangueras en busca de cortes, abrasiones y daño.</p>	<p><b>CUIDADO:</b> Puede ser macho en temperaturas frías puede dañar el sistema hidráulico. El no flujo de aceite, el indicador de vacío mostrará alto en la escala.</p> <p><b>LISTA DE VERIFICACION SEMANAL:</b> Asegúrese de que los pernos de montaje de la mezcladora estén apretados. Que los pernos de montaje del accionamiento directo estén apretados. Que los soportes del tanque de agua estén apretados. Que los pernos de montaje del PTO estén apretados. Que los rodillos estén correctamente alineados. Que el accionamiento directo está completamente lubricado. Que el depósito del elevador de la sarena está lleno, con las canchales hacia abajo.</p>	<p><b>DATOS IMPORTANTES:</b></p> <ol style="list-style-type: none"> <li>Si el indicador de vacío del aceite permanece sobre 0 después del período de calentamiento, se debe cambiar el filtro del aceite.</li> <li>Mientras que se conduce el vehículo, el tambor debe girar para evitar dañar el rodillo del tambor.</li> <li>La presión de aire en el tanque de agua no debe exceder 22 libras (10 libras) de presión.</li> </ol>
--	---	---

780.115117

© 3/01 McNeilus Truck and Manufacturing Inc. All Rights Reserved

32

DO NOT PAINT OVER THIS LABEL / NO PINTAR ENCIMA DE ESTA ETIQUETA

## OPERATOR'S INSTRUCTION

McNeilus will not accept responsibility for damage to paint, hydraulic cylinders, or any indirect damage resulting from the use of acid based cleaners on this mixer.

## INSTRUCCIONES PARA EL OPERADOR

McNeilus no se hace responsable por daños en la pintura. Los cilindros hidráulicos, o cualquier otro daño ocasionado por el uso de limpiadores que contienen ácido.

780.215141

©12/97 McNeilus Truck and Manufacturing Co. All Rights Reserved

33



34

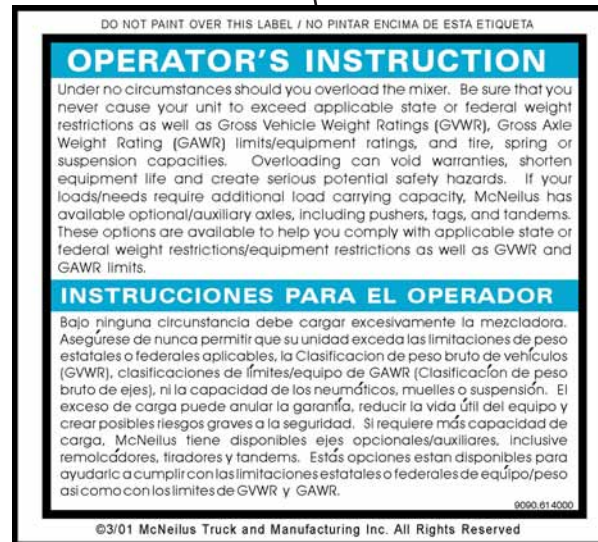

35

DO NOT PAINT OVER THIS LABEL / NO APLICAR PINTURA SOBRE ESTA ETIQUETA

<b>⚠ DANGER</b>	<b>⚠ PELIGRO</b>
	<p>MIRE HACIA ARRIBA Y VIVA. Asegúrese de que exista suficiente distancia entre una hormigonera y las líneas de alimentación aéreas. No es necesario que la hormigonera esté en contacto con los cables para que se transmita electricidad a la unidad. Si la unidad contacta con una línea de alimentación, permanezca en la cabina y manténgase LEJOS DE LAS PARTES METÁLICAS DE LA UNIDAD. Podría sufrir lesiones graves o fatales.</p>
<p><b>LOOK UP AND LIVE.</b> Make sure there is enough clearance between a mixer and overhead power lines. It is not necessary for the mixer to be in contact with the electric cable for the electricity to go through the unit. If unit does come in contact with a power line, stay in the cab and <b>KEEP AWAY FROM THE METAL PARTS OF THE UNIT.</b> Serious personal injury or death can occur.</p>	1394101
©10/08 McNeilus Truck and Manufacturing, Inc. All Rights Reserved / Todos los derechos reservados	

36

DO NOT PAINT OVER THIS LABEL / NO PINTAR ENCIMA DE ESTA ETIQUETA

<b>⚠ CAUTION</b>	<b>⚠ PRECAUCION</b>
<p>Oil temperatures may exceed 120° F. This could result in burns to the skin.</p>	<p>La temperatura del aceite puede exceder 120° F. Esto puede ocasionar quemaduras en la piel.</p>
780.115100	
©9/02 McNeilus Truck and Manufacturing Inc. All Rights Reserved	

37

DO NOT PAINT OVER THIS LABEL / NO PINTAR ENCIMA DE ESTA ETIQUETA

## OPERATOR'S INSTRUCTION

### Hydraulic Oil and Filter Elements

Change Hydraulic Oil and Filters after First 100 Hours and every 6 months/1000 hours thereafter  
 Temperature over 80°F use ISO100 Hydraulic Oil  
 Temperature under 80°F use ISO68 Hydraulic Oil

### Minimum Filter Rating for Hydrostats:

Beta 10=2 with 28" of Vacuum Capability  
 ISO 18/13 Cleanliness Must Be Maintained  
 Call McNeilus for Assistance if Required at: (507) 374-6321

## INSTRUCCIONES PARA EL OPERADOR

### Aceite hidráulico y elementos de filtro

Cambie el aceite hidráulico y los filtros después de las primeras 100 horas y cada 6 meses/1000 horas en lo sucesivo.  
 Con temperaturas sobre los 80°F use aceite hidráulico Iso100  
 Con temperaturas bajo los 80°F use aceite hidráulico ISO68

### Capacidad nominal mínima del filtro para hidrostatos:

Beta 10=2 con 20" de capacidad de aspiración  
 Debe mantenerse el nivel de limpieza de conformidad con la norma ISO 18/13  
 Llame a McNeilus para asistencia si es necesario al: (507) 374-6321

780.129702

©3/99 McNeilus Truck and Manufacturing Co. All Rights Reserved

38

DO NOT PAINT OVER THIS LABEL / NO PINTAR ENCIMA DE ESTA ETIQUETA

## ⚠ DANGER



### NEVER LEAN OR CLIMB OVER RAILING.

Stay clear of moving drum or parts.  
 Serious personal injury may result from contact with rotating equipment.

## ⚠ PELIGRO

### NUNCA SUBA NI SE ASOME POR EL BARANDAL

Manténgase lejos de los componentes móviles del tambor.  
 El contacto con el equipo giratorio puede provocar lesiones graves.

780.129709

©3/01 McNeilus Truck and Manufacturing Inc. All Rights Reserved

39

DO NOT PAINT OVER THIS LABEL / NO PINTAR ENCIMA DE ESTA ETIQUETA

**⚠ WARNING**

The hopper prop pin must be moved from stowed position to locked position when standing on upper ladder platform with the charge hopper raised. This will prevent lowering of the hopper. Failure to do so could result in serious injury.

**⚠ ADVERTENCIA**

Cuando quiera subirse a la plataforma superior de la escalera estando levantada la tolva de carga (hopper), debe sacar el pasador del soporte de la tolva de la posición de almacenaje (stowed) y ponerlo en la posición de bloqueo (locked). Esto evitará que la tolva caiga repentinamente. De no hacerlo, la tolva puede causar heridas graves.

1138173

©8/02 McNeilus Truck and Manufacturing Inc. All Rights Reserved

40

DO NOT PAINT OVER THIS LABEL / NO PINTAR ENCIMA DE ESTA ETIQUETA

**⚠ DANGER**

Do not climb on ladder or stand on platform while truck is in motion. Serious personal injury or death can occur due to a fall.

**⚠ PELIGRO**

No se suba a la escalerilla ni se pare en la plataforma mientras el camión esté en movimiento. Podría ocurrir una lesión personal seria debido a una caída.

780.214687

©12/97 McNeilus Truck and Manufacturing Inc. All Rights Reserved

41

DO NOT PAINT OVER THIS LABEL / NO PINTAR ENCIMA DE ESTA ETIQUETA

**⚠ DANGER**



Use extreme care and a three point stance when on ladder or platform. Position yourself so that you do not contact any moving or rolling parts. Do not place any part of your body inside the drum. A slip or snagging of tools, clothing, or yourself could result in personal injury or death.

**⚠ PELIGRO**

Tenga sumo cuidado y adopte una postura de tres puntos si está sobre una escalera o una plataforma. Colóquese de manera que no entre en contacto con ninguna parte en movimiento o rodando. No ponga ninguna parte de su cuerpo dentro del tambor. El resbalamiento o atrapamiento de herramientas, de vestiduras o de usted mismo, podría dar como resultado una lesión personal seria o la muerte.

780.214666

©5/10 McNeilus Truck and Manufacturing, Inc. All Rights Reserved

43

DO NOT PAINT OVER THIS LABEL / NO PINTAR ENCIMA DE ESTA ETIQUETA

**⚠ CAUTION**



KEEP HANDS AND BODY AWAY FROM PIVOT POINTS

**⚠ PRECAUCION**

MANTENGA LAS MANOS Y EL CUERPO FUERA DE LAS PUNTAS DEL PIVOTE

780.215129

© 2010 McNeilus Truck and Manufacturing, Inc. All Rights Reserved

44

DO NOT PAINT OVER THIS LABEL / NO PINTAR ENCIMA DE ESTA ETIQUETA

## SAFETY NOTICE

- BEFORE ENTERING DRUM, read and follow OSHA Regulations concerning entry and working in "CONFINED SPACE" OSHA 1910.146 and "LOCKOUT/TAGOUT" OSHA 1910.147.
- Refer to safety lockout procedure for McNeilus Transit and Stationary Mixers Instruction Bulletin for additional procedures. Following procedures pertain to the use of McNeilus Lockout Procedure Kit #780.02024.
- Shut off truck engine and carry all sets of ignition keys in your pocket.
- NOTE: Position of control valve arm. Remove hydrostatic pump control valve arm. Place lockout with red "Danger Lockout" tag thru splined hole of control valve arm, attach padlocks and carry all keys in your pocket.
- Place magnetic "DANGER" signs on both cab doors.
 

**⚠ DANGER**  
 No admittance to this area until authorized personnel have been notified.  
 No admittance to this area until authorized personnel have been notified.
- Place dual turnbuckle wedge assembly base on rear pedestal. Make sure wedge assembly base has a flat clean surface. Extend turnbuckles so wedges are firmly in place between drum roller track and rollers. Evenly snug up turnbuckles one-turn or more if necessary to prevent possible drum rotation. Tighten the turnbuckle jam nuts to secure the wedges in place.
- When finished, remove dual turnbuckle wedge assembly FIRST, then unlock control valve arm and remove "DANGER" sign from doors. Serious personal injury or death can occur.

## AVISO DE SEGURIDAD

- ANTES DE ENTRAR AL TAMBOR lee y siga los Reglamentos de OSHA referentes al ingreso y trabajo en "ESPACIOS REDUCIDOS" ("CONFINED SPACE") OSHA 1910.146 y "CERRAM/AMARCAR" ("LOCKOUT/TAGOUT") OSHA 1910.147.
- Consulta el Procedimiento de cierre de seguridad para el Sistema de Tráfico y Mezcladoras Estacionarias McNeilus para ver procedimientos adicionales. Los procedimientos siguientes se refieren al uso del Juego para Procedimiento de Cierre McNeilus No. 780.02024.
- Apague el motor de camión y llevese todos los juegos de llaves de encendido en el bolsillo.
- NOTA: Ponga el brazo de la válvula de control en la posición indicada. Retire el brazo de la válvula de control de la bomba hidrostática. Coloque un letrero de color rojo indicando "Peligro-Cierre" por la ranura del brazo de la válvula de control, coloque candados y llevese todas las llaves en el bolsillo.
- Coloque letreros de "Peligro" en ambas puertas de la cabina.
- Coloque una base de conjunto de cuñil de doble torniquete en el pedestal posterior. Asegúrese que la base de cuñil tiene una superficie plana y limpia. Ajuste los torniquetes para que las cuñiles estén firmemente colocadas entre la pista de rodadura del tambor y los rodillos. Ajuste los torniquetes con una vuelta o más si es necesario, para evitar la posibilidad de que el tambor se ruede. Ajuste las tuercas de embudo de los torniquetes, para asegurarse que las cuñiles estén fijas.
- Cuando termine, PRIMERO retire el conjunto de cuñil de doble torniquete, luego desconecte el seguro del brazo de la válvula de control y retire los letreros de "Peligro" de las puertas.  
 Pueden ocurrir lesiones personales graves o fatales. 780.02024-0

©/3/02 McNeilus Truck and Manufacturing Inc. All Rights Reserved

45

DO NOT PAINT OVER THIS LABEL / NO PINTAR ENCIMA DE ESTA ETIQUETA

## SAFETY NOTICE

# Always secure foldover chute with safety chain.

## AVISO DE SEGURIDAD

Siempre asegure la canaleja  
doblada con la cadena de  
seguridad.

780.215095

©3/01 McNeilus Truck and Manufacturing Inc. All Rights Reserved

46



47

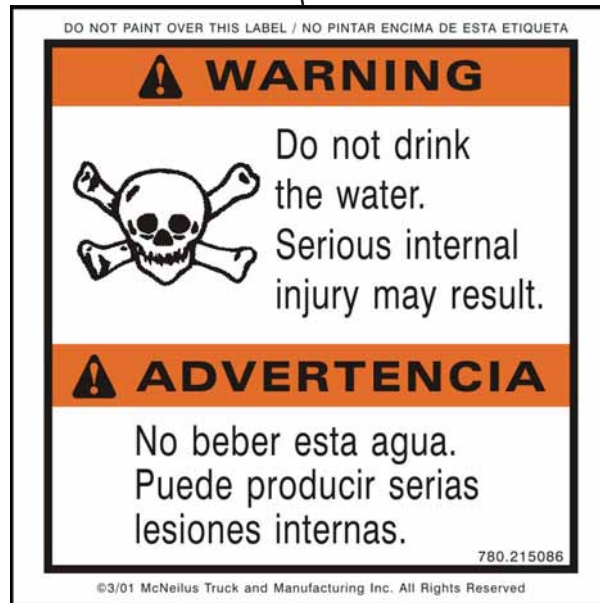

48

DO NOT PAINT OVER THIS LABEL / NO PINTAR ENCIMA DE ESTA ETIQUETA

**CAUTION**



Use care and a three point stance when climbing on ladder or platform, which may be slippery. Serious personal injury can occur due to a fall.







**PRECAUCION**

Tenga cuidado y adopte una postura de tres puntos al subir por una escalera o plataforma, ya que pueden estar resbaladizas. Una caída puede ocasionar graves lesiones personales.

780.215058

©5/10 McNeilus Truck and Manufacturing, Inc. All Rights Reserved

49

 <p>DRIVE IN ENTRE ENTRE EN AVANÇANT</p>	 <p>BACK IN RETROCEDA ENTRE EN RECLANT</p>	 <p>BACK UP RETROCEDA RECULE</p>
 <p>PULL FORWARD HACIA ADELANTE AVANCE</p>	 <p>STOP ALTO ARRÊTE</p>	 <p>RAISE CHUTE LEVANTE EL CONDUCTO MONTE LA CHUTE</p> <p>LOWER CHUTE BAJE EL CONDUCTO DESCEND LA CHUTE</p>
 <p>START POURING EMPIECE A VACIAR COMMENCE À DÉVERSER</p>	 <p>MORE WATER MAS AGUA PLUS D'EAU REQUIS</p>	 <p>STOP POURING DEJE DE VACIAR ARRÊTE DE DÉVERSER</p>

50

DO NOT PAINT OVER THIS LABEL / NO PINTAR ENCIMA DE ESTA ETIQUETA

**DANGER**

- Inspect water tank daily for damage including, but not limited to, dents, gouges in metal or leaks.
- Do not weld or repair tank.
- If water tank is damaged and/or leaks, it must be replaced with a new OEM tank before Mixer is returned to service.
- Do not pressurize an empty water tank.
- Depressurize water tank prior to transit to or from job.
- Do not pressurize water tank beyond 55 psi.
- Never remove regulator or safety valve from water tank.
- Refer to McNeilus Operator's Manual or contact McNeilus Mixer Service at 888.686.7278 if you have any questions or require assistance.



**PELIGRO**

- Inspeccione el tanque de agua a diario para verificar si hay daños, incluyendo, entre otros, abolladuras, perforaciones en el metal o fugas.
- No suelde ni repare el tanque de agua.
- Si el tanque de agua está dañado o tiene fugas, debe ser reemplazado por un nuevo tanque del fabricante del equipo original antes de devolver el mezclador al servicio técnico.
- Nunca presurice un tanque de agua vacío.
- No presurice el tanque de agua a menos que el tanque esté lleno de agua.
- Despresurice el tanque de agua antes de transportarlo hacia o desde el lugar de trabajo.
- No presurice el tanque de agua más allá de 55 psi.
- Nunca quite el regulador ni la válvula de seguridad del tanque.
- Consulte el Manual del usuario McNeilus o comuníquese con el servicio técnico del mezclador McNeilus al 888.686.7278 si tiene preguntas o necesita asistencia.

1420547

© 2010 McNeilus Truck and Manufacturing, Inc. All Rights Reserved

51

DO NOT PAINT OVER THIS LABEL / NE PAS PEINDRE CETTE ÉTIQUETTE

**OPERATOR'S INSTRUCTION**

**WATER PUMP**

WITH TRUCK RUNNING ENSURE 100 PSI TO PUMP  
CLOSE PURGE DRAIN BALL VALVE AT PUMP INLET  
OPEN WATER VALVE FROM TANK  
TURN ON AIR PRESSURE TO PUMP  
OPEN SPRAY VALVE TO PRESSURIZE WATER LINE  
TRUCK MUST BE AT 2000 RPM FOR WATER INJECTION  
WHEN TEMPERATURE IS BELOW 32° F WATER SYSTEM MUST BE PURGED AFTER EACH USE TO PREVENT FREEZING

**WATER SYSTEM PURGE**

TURN ON AIR PRESSURE TO PUMP  
WITH TRUCK RUNNING ENSURE 100 PSI TO PUMP  
CLOSE WATER VALVE FROM TANK  
OPEN PURGE DRAIN BALL VALVE  
EMPTY WATER FROM EACH SPRAY OUTLET  
ALLOW SYSTEM TO PRESSURIZE BACK UP WITH AIR  
EMPTY ANY EXISTING WATER FROM EACH OUTLET  
SHUT OFF AIR SUPPLY TO PUMP  
OPEN ALL OUTLETS UNTIL NEXT USE

**DIRECTIVE POUR L'OPÉRATEUR**

**POMPE À EAU**

LORSQUE LE CAMION FONCTIONNE,  
LA PRESSION JUSQU'À LA POMPE DOIT ÊTRE DE 6,9 BARS (100 LB/PO)  
FERMER LA SOUPAPE À BILLE DE PURGE AU NIVEAU  
DE L'ORIFICE D'ASPIRATION DE LA POMPE  
OUVRIR LE ROBINET DE PRISE D'EAU PROVENANT DE RÉSERVOIR  
OUVRIR LA PRESSION D'AIR VERS LA POMPE  
OUVRIR LA SOUPAPE DE PULVÉRISEMENT POUR PRESSURISER LE TUYAU D'EAU  
LE CAMION DOIT FONCTIONNER À 2 000 TR/MIN POUR L'INJECTION D'EAU  
LORSQUE LA TEMPÉRATURE EST INFÉRIEURE À 0°C, LE SYSTÈME  
D'EAU DOIT ÊTRE VIDÉ APRÈS CHAQUE UTILISATION POUR  
ÉVITER LE GEL

**VIDANGE DU SYSTÈME D'EAU**

OUVRIR LA PRESSION D'AIR VERS LA POMPE  
LORSQUE LE CAMION FONCTIONNE,  
LA PRESSION JUSQU'À LA POMPE DOIT ÊTRE DE 6,9 BARS (100 LB/PO)  
FERMER LE ROBINET DE PRISE D'EAU PROVENANT DU RÉSERVOIR  
OUVRIR LA SOUPAPE À BILLE DE PURGE  
VIDER L'EAU DE CHAQUE ORIFICE DE PULVÉRISEMENT  
LAISSER LE SYSTÈME SE REMETTRE SOUS PRESSION AVEC DE L'AIR  
VIDER TOUTE EAU PRÉSENTE DANS CHAQUE ORIFICE  
COUPER L'ALIMENTATION EN AIR VERS LA POMPE  
OUVRIR TOUTS LES ORIFICES JUSQU'À LA PROCHAINE UTILISATION

1281178

© 2010 McNeilus Truck and Manufacturing, Inc. All Rights Reserved

52

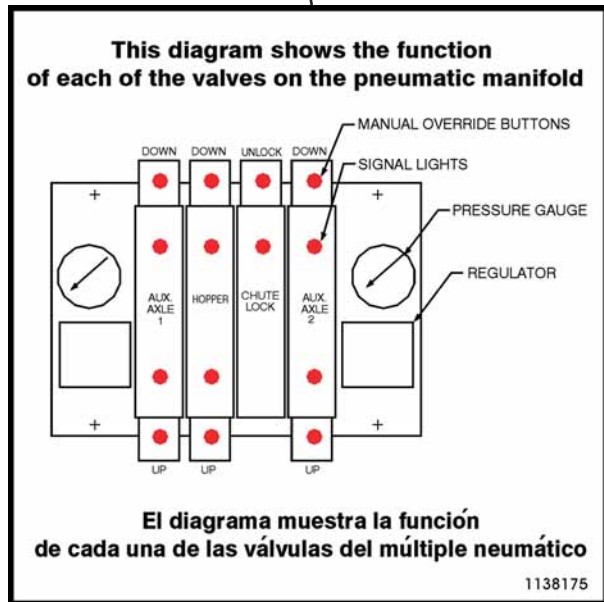

53

DO NOT PAINT OVER THIS LABEL / NO PINTAR ENCIMA DE ESTA ETIQUETA / NE PAS PEINTUREZ CET ÉTIQUETTE

**OPERATOR'S INSTRUCTION**

Drain Coalescing Filter Bowl Daily.

**INSTRUCCIONES PARA EL OPERADOR**

Drene diariamente el receptáculo Del Siltro coalescente.

**INSTRUCTIONS À L'OPÉRATEUR**

Vidangez le bol du filtre coalescent quotidiennement

1326487

©5/07 McNeilus Truck and Manufacturing, Inc. All Rights Reserved

54

**McNeilus**  
**GENUINE REPLACEMENT PARTS**

Protect your investment in McNeilus equipment. Do not jeopardize your warranty. Use only genuine McNeilus replacement parts. Original McNeilus parts insure the finest quality, the longest life and proper, reliable operation.

CALL YOUR LOCAL MCNEILUS BRANCH

CORPORATE HEADQUARTERS  
 P.O.Box 70, County Road 34, Dodge Center, MN 55927  
 FAX:507-374-6306 Phone:507-374-6321

BRANCH FACILITIES

<b>CALIFORNIA</b> Phone:909-370-2100	<b>COLORADO</b> Phone:303-287-7486	<b>UTAH</b> Phone:801-954-8709
<b>PENNSYLVANIA</b> Phone:610-286-0400	<b>OHIO</b> Phone:614-868-0760	<b>WASHINGTON</b> Phone:253-536-0260
<b>GEORGIA</b> Phone:770-489-5151	<b>TEXAS</b> Phone:972-225-2313	

MADE IN THE U.S.A.  
 WITH PRIDE.

780.214523

55

DO NOT PAINT OVER THIS LABEL / NO PINTAR ENCIMA DE ESTA ETIQUETA

**NOT A STEP**

**NO ES UN ESCALON**

1139944

©10/02 McNeilus Truck and Manufacturing Inc. All Rights Reserved

56



58



59



60



61

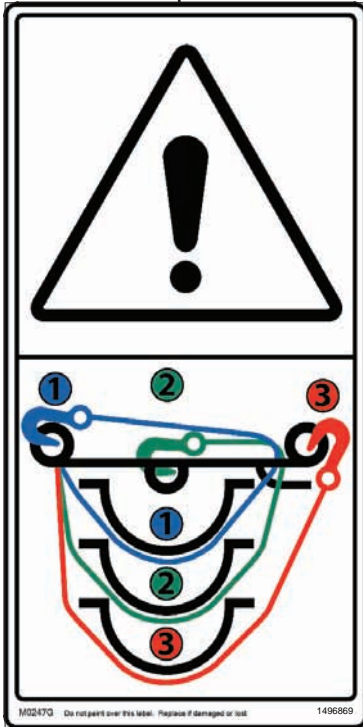

## NOTES

# 1.0 Exterior Systems Arrangement

## 1.1 Curb Side View

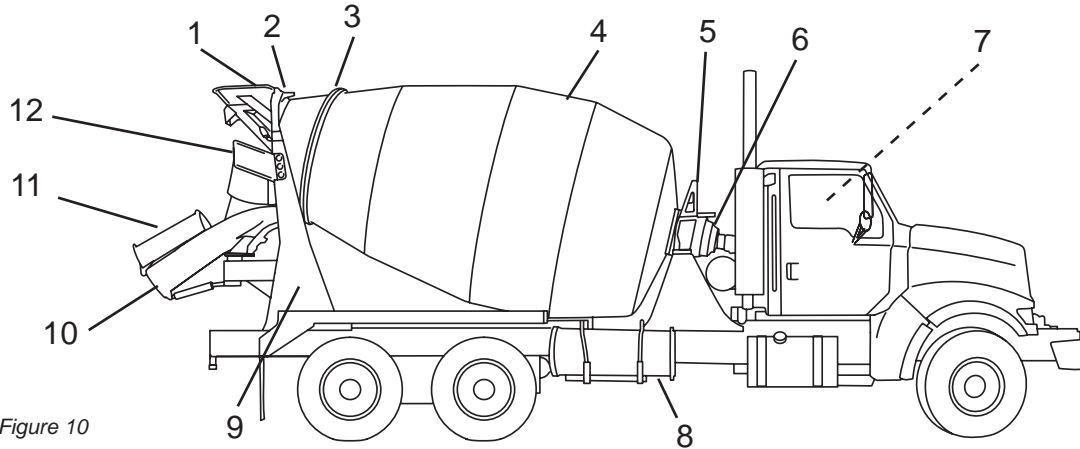

Figure 10

Ref No.	System Description
1	Charge Hopper
2	Debouncer
3	Drum Roller Track (Ring)
4	Drum
5	Hydraulic Oil Cooler (Location May Vary)
6	Drum Drive

Ref No.	System Description
7	Cab Control Box
8	Chute Extensions (Location May Vary)
9	Rear Pedestal
10	Main Chute
11	Fold-Over Chute
12	Collector

1.2 Street Side View

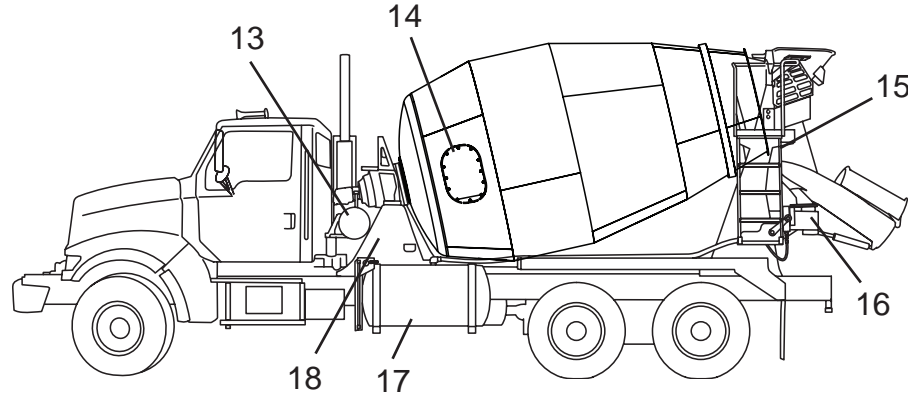

Figure 11

Ref. No.	System Description
13	Hydraulic Oil Reservoir (Location May Vary)
14	Drum Hatch
15	Drum Access Ladder
16	Rear Control Pendant
17	Water Tank (Location May Vary)
18	Front Pedestal

## 1.0 Before Placing the Mixer Into Service

After delivery, it will be necessary to prepare the Mixer for normal operation.

1. Remove cable ties securing the access ladder.
2. De-activate the Transport Lock using the control display (see Display operations).
3. Securely mount the emergency equipment.
  - a. Mount the fire extinguish in an area that is readily accessible, and in a manner that prevents sliding, rolling, or vertical movement.
  - b. The mounting location of the triangle kit and spare fuse kit is at the discretion of the final user.
4. Attach and securely stow wash-out hose(s).
5. Inspect all mounting hardware to see if any has loosened during delivery. Retighten hardware as needed.
6. Inspect all hydraulic lines and hoses for leaks.
7. Charge the Mixer with a quantity of stone and sand. Rotate the drum for 1-1/2 to 2 hours to clean the interior of any weld slag or splatter. This will polish the blades and reduce the possibility of concrete adhering to the drum interior.

## 1.1 Transport Feature

After delivery, it will be necessary to prepare the Mixer for normal operation.

1. Remove the cable tie (Figure 12, Item 1) securing the hydraulic pump linkage in the TRANSPORT mode. The TRANSPORT mode constantly rotates the drum in the CHARGE direction at a speed of 1 to 1-1/2 rpm. This prevents the drum rollers from becoming damaged during transport.

2. Reinstall the cab chute control fuse (Figure 13).

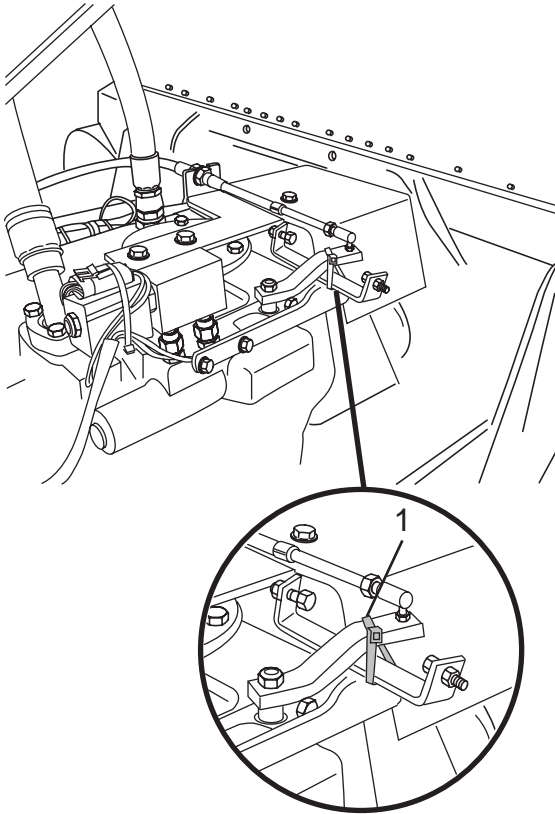

Figure 12

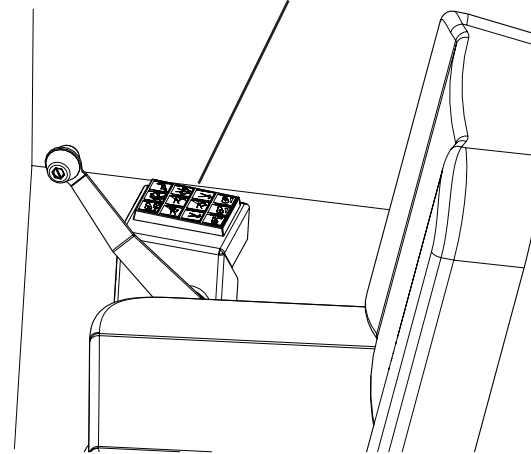
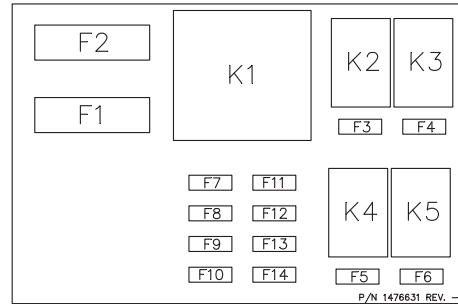

Figure 13

3. Remove cable ties securing the access ladder(s).
4. Attach and securely stow wash-out hose(s).
5. Securely mount the emergency equipment:
  - a. Mount the fire extinguisher in an area that is readily accessible, and in a manner that prevents sliding, rolling, or vertical movement.
  - b. The mounting location of the triangle kit and spare fuse kit is at the discretion of the final user.
6. Inspect all mounting hardware to see if any has loosened during delivery. Retighten hardware as needed.
7. Inspect all hydraulic lines and hoses for leaks.
8. Charge the Mixer with a quantity of stone and sand. Rotate the drum for 1-1/2 to 2 hours to clean the interior of any weld slag or splatter. This will polish the blades and reduce the possibility of concrete adhering to the drum interior.

**NOTE:** Activate the Transport Mode on the cable control by installing a zip tie on the pump controller lever.

## 2.0 Instruments and Controls

The following figures and tables identify and describe the controls used on this equipment. These instructions include optional features that may or may not be included on your Mixer.

To make sure you understand proper operating procedures, read this section and carefully practice with the controls and instruments to learn how to safely operate the equipment.

### 2.1 Electronic Drum Control System

The Electronic Drum Control System consists of a touch screen control pad (Figure 14).

No.	Item	Description
1	Joystick Condition Monitor	Not applicable.
2	Rear Pendant Condition Monitor	Indicates if Rear Pendant is enabled (green) or disabled (red).
3	Bridgmaster Axle Condition Indicator	Not applicable.
4	Chute Condition Indicator	Chute centered and down.
5	Hopper Condition Indicator	Hopper up or down indicators. (Shown Hopper Down.)
6	Chute Lock Condition Indicator	Chute locked. (Chute shown locked.)

No.	Item	Description
7	Drum Operation Monitor	Displays drum RPM and direction of rotation.
8	Error/Fault Indicator	Indicates if there is an error.
9	Mix Drum Counter	Number of drum revolutions achieved during mix mode only.
10	Trip Counter	Operator resettable counter.
11	Non-Resetting Counter	Non-resettable cumulative counter.
12	Work Light Function	Touch to access lighting and camera functions.
13	Add Water Functions/Slump Meter	Touch to access slump functions.
14	Drum Control Functions	Touch to access drum control functions (from display).
15	Auxiliary Axle Functions	Touch to access lift axle functions.
16	Home Screen Selector	Touch to return to the HOME screen.
17	Oil Temperature Indicator	Displays current oil temperature (OPTIONAL).
18	Fan Manual ON/OFF Button	Touch to manually turn on hydraulic fan cooler.
19	Rear Pendant Enable Button	Touch to enable control from the rear control pendant.

No.	Item	Description
20	Optional Drum Control Joystick Enable Button	Not applicable.

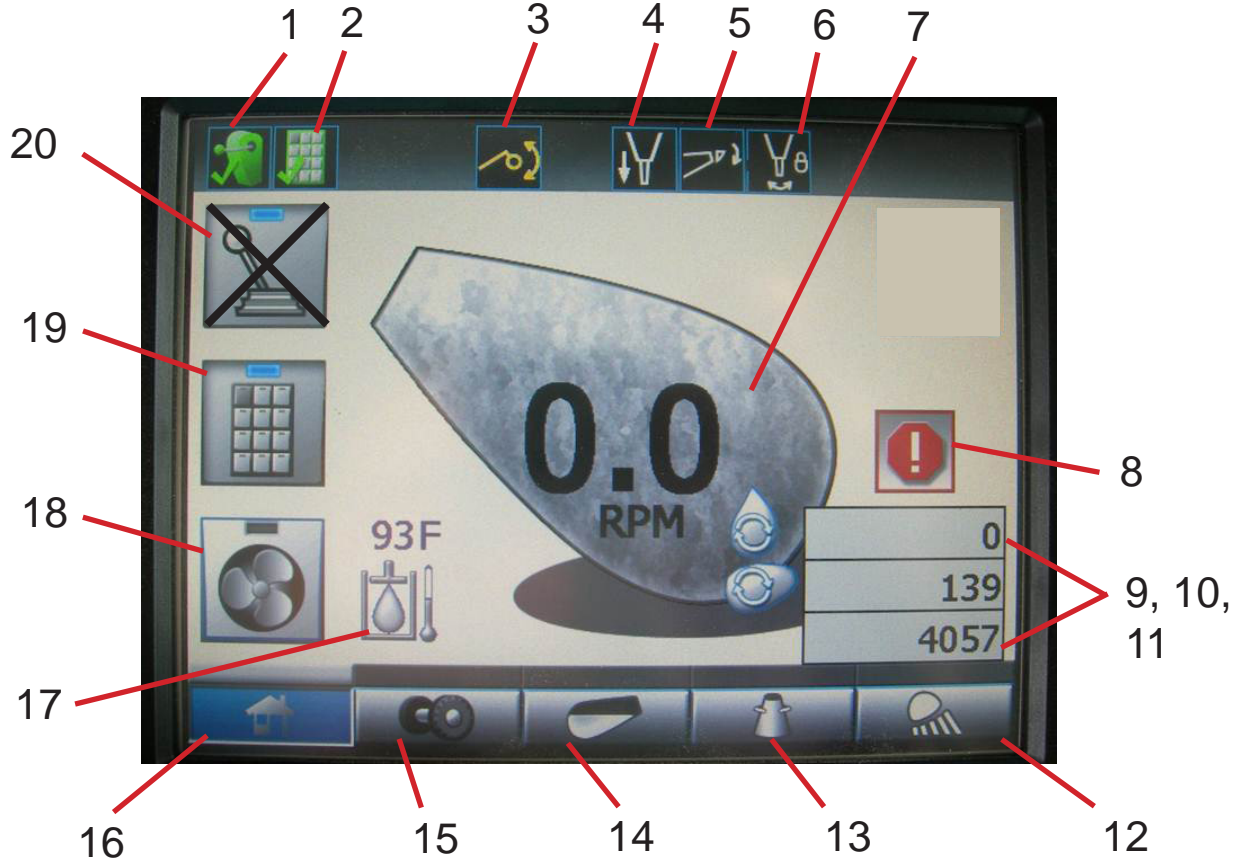

Figure 14

## 2.2 Touch Screen Display Status Icons



Not Applicable -  
Bridgmaster Down



Not Applicable -  
Bridgmaster Up



Not Applicable -  
Bridgmaster In Motion



Chute Centered



Chute Not Centered



Chute Left



Chute Right



Chute Centered and Down



Chute Not Centered and Not Down



Chute Locked



Chute Unlocked



Drum Charge



Drum Discharge



Drum Stop



Slump High



High Oil Temperature



Low Oil



Hopper Up



Hopper Down



Joystick Enabled - Not applicable



Joystick Disabled - Not applicable



Keypad Enabled



Keypad Disabled



Lights On



Strobe Lights On

### 2.3 Cab Controls - Cab Control Pendant

The in-cab controls consist of a control pendant and the cable control lever (Figure 15).

No.	Item	Description
1	Constant Speed	Not applicable.
2	Mix Mode	Not applicable.
3	Load Mode	Not applicable.
4	Chute Lock	Green LED when locked and Red LED when unlocked.
5	Chute Swing Right	Moves chute to the right (Power Chute Swing Option only). Green LED is on when button is pressed.
6	Drum Discharge	Not applicable.
7	Drum Charge	Not applicable.
8	Chute Down	Green LED while button is pressed.
9	Drum Start/Stop	Not applicable.
10	Chute Swing Left	Moves chute to the left (Power Chute Swing Option only). Green LED is on when button is pressed.
11	Hopper Up/Down	Green LED when air hopper is DOWN. Red LED when air hopper is UP.
12	Chute Up	Green LED while button is pressed.

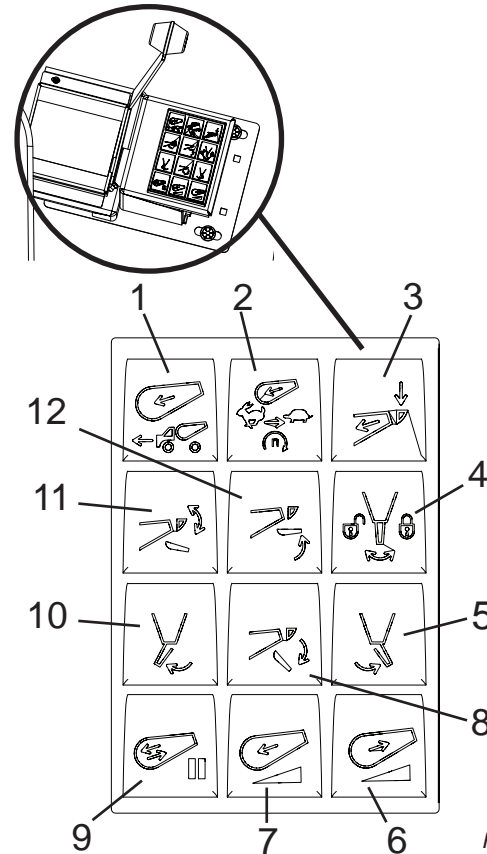

Figure 15

## 2.4 Fuse Functions

If a function in the cab pendant controls or rear pendant controls does not operate, check the condition of the fuses (Figure 16) located in the cover of the control fuse box (in the cab control pendant) or the rear of the control box (cab control box). A label is located beside the fuses to identify the functions they control.

**CAUTION**

**Do not replace a fuse with a higher amperage fuse than is listed for the location. Always use new fuses of the correct amperage.**

**Using a fuse with a higher amperage may cause damage to the equipment.**

Fuse No.	Amperage Rating	Description
F9	10 amp	In-Cab Touch Pad and Joystick Power
F10	10 amp	Sensor Power
F11	10 amp	Controller Power 1
F12	30 amp	Controller Power 2
F13	5 amp	Display Power
F14	10 amp	Wireless Control Power
K1	Relay	System
K2	Relay	Cooling Fan
K3	Relay	Strobe Lights
K4	Relay	Work Lights
K5	Relay	Perimeter Lights

Fuse No.	Amperage Rating	Description
F1	60 amp	System
F2	25 amp	Cooling Fan
F3	5 amp	Telematics Power (Not Currently Used)
F4	10 amp	Strobe Light
F5	10 amp	Work Lights
F6	10 amp	Perimeter Lights
F7	2 amp	Rear Pendant
F8	- amp	Not Used

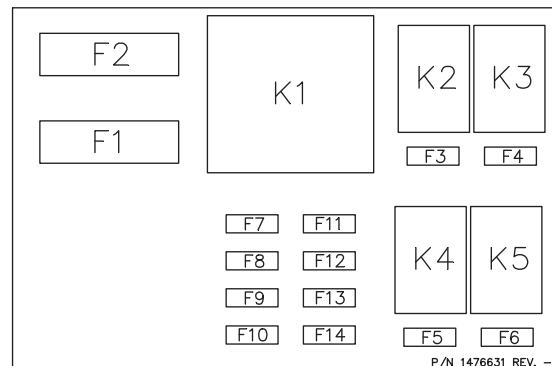

Figure 16

## 2.5 Outside Controls

The outside controls consist of an optional rear pendant (Figure 17, Item 1), a manual chute lock (Figure 17, Item 2), and drum cable control (Figure 17, Item 3).

No.	Item	Description
1	Rear Control Pendant	Contains keypad to control various mixer functions. The controls contained will vary, depending on options.
2	Manual Chute Lock	Mechanically locks the main chute in one of several positions.
3	Drum Control	Contains the drum control lever that controls the speed and direction of the drum rotation. Early models may also contain toggle switches to control various mixer functions. The controls contained will vary, depending on options.

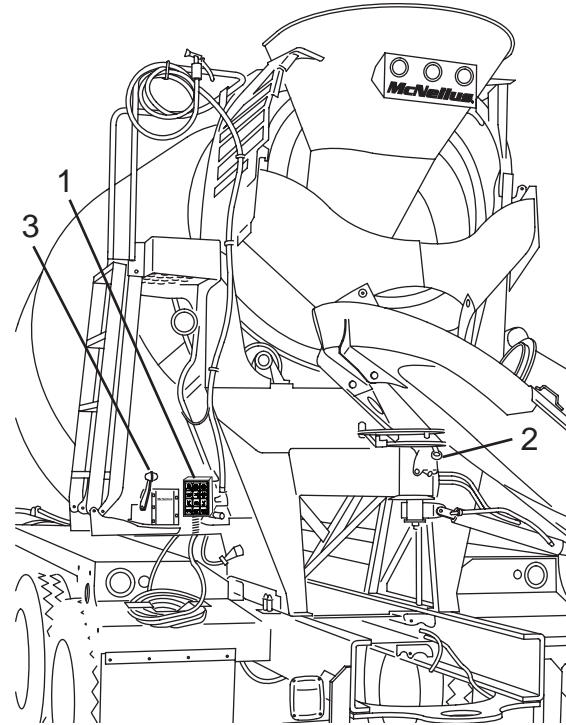

Figure 17

## 2.5.1 Rear Pendant Controls

Accessories and mixer functions and some options are operated by buttons on the rear control pendant (Figure 18). The actual buttons present on the control pendant will vary, depending on the configuration of your Mixer. The operator can take the rear pendant up the ladder platform for quick access to starting and stopping the drum (optional).

No.	Item	Operation
12	Hopper Up/Down	Green LED when air hopper is DOWN. Red LED when air hopper is UP.

No.	Item	Operation
1	Bridgemaster Stop	Not applicable.
2	Throttle Down	Slows the engine throttle. Active while the truck is in neutral and park brake is set.
3	Throttle Up	Speeds engine throttle. Active while the truck is in neutral and park brake is set.
4	Chute Up	Green LED while button is pressed.
5	Chute Lock	Green LED while button is pressed.
6	Chute Swing Right	Moves chute to the right (Power Chute Swing Option only). Green LED is on when button is pressed.
7	Drum Discharge	Not applicable.
8	Drum Charge	Not applicable.
9	Drum Start/Stop	Starts or stops the drum (Optional).
10	Chute Swing Left	Moves chute to the left (Power Chute Swing Option only). Green LED is on when button is pressed.
11	Chute Down	Green LED while button is pressed.

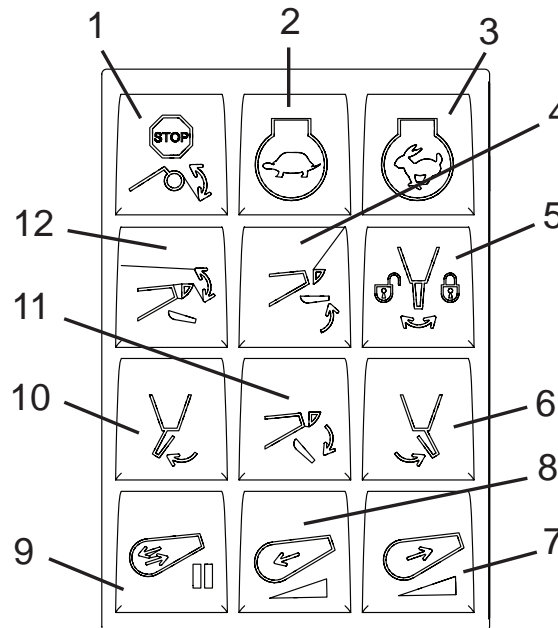

Figure 18

**2.5.2 Drum Control**

The rear drum control (Figure 19).

No.	Control	Normal Use or Reading
1	DRUM CONTROL LEVER (CHARGE/ DISCHARGE)	<p>Starting at the NEUTRAL position, pushing the lever forward (away from the operator) starts the drum rotating in the CHARGE direction. The farther the lever is pushed forward, the faster the drum rotates.</p> <p>Pulling the lever back (toward the operator) will decrease the drum speed until the NEUTRAL position is reached at which point the drum stops rotating.</p> <p>From the NEUTRAL position, pulling lever back (toward the operator) will start the drum rotating in the DISCHARGE direction. The farther the lever is pulled back, the faster the drum rotates.</p>

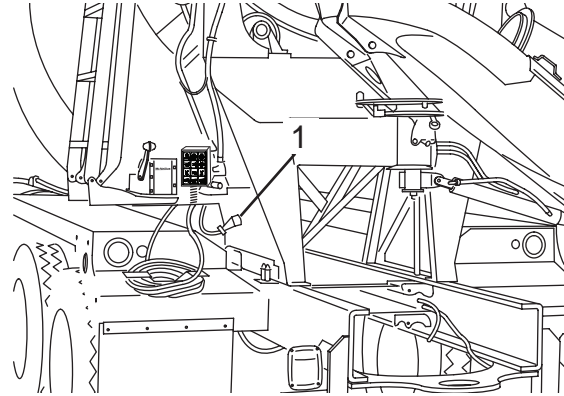

Figure 19

### 2.5.3 Manual Chute Lock

#### **CAUTION**

**Do not move the vehicle without locking the chute with the manual chute lock. Do not use the chute air lock to secure the chute for transport.**

**Driving the vehicle without the chute properly locked may cause damage to equipment.**

The manual chute lock mechanically locks the chute in one of several pre-determined positions.

To move the chute:

1. Unlock the chute air lock (if equipped).
2. While holding the chute, pull down on the lever (Figure 20, Item 1) and move it to the right or left until the lever is seated in one of the lock positions.
3. Move the main chute (Figure 20, Item 2) to the desired position, and while holding the chute, move the lever to the center. Make sure the lever pin is fully seated into one of the holes in the chute plate before releasing the chute. Move the chute from side to side as needed to align the pin and hole.

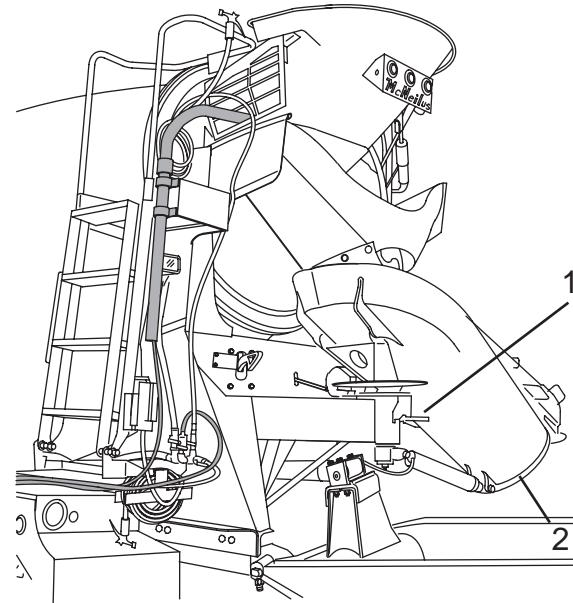

Figure 20

## 2.6 Manual Drum Operation

### 2.6.1 Manual Override - CHARGE and DISCHARGE

If the mixer cable control fails, and there is still a need to rotate the drum, the control cable can be disconnected to allow the pump drum drive to be engaged manually. This will allow the Mixer to be unloaded.

To engage the drum drive:

1. Pull back and hold the head (Figure 21, Item 1) of the control cable, and lift the end of the cable off the pivot (Figure 21, Item 2) to disconnect the control cable from the pump control lever (Figure 21, Item 3).
2. Move the pump control lever (Figure 21, Item 3) as required to start the drum rotation in the charge or discharge direction.
3. If the drum controls are still disabled after unloading, see Manual Override - Locking for Transit to configure the drum drive for transit.

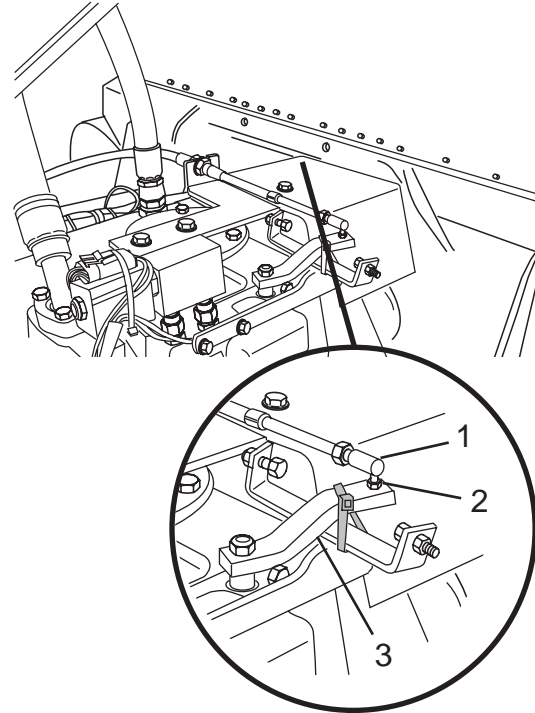

Figure 21

### 2.7 OMNEX® Wireless Remote Control (Optional)

The OMNEX® Wireless Remote Control system consists of a transmitter, and a receiver that is connected to the mixer electronic control system.

#### 2.7.1 OMNEX® Wireless Remote Control (Cab Console Version)

The transmitter (Figure 22, Item 1) when not in use is stored in the docking cradle (Figure 22, Item 2). The cradle will automatically charge the transmitter whenever the transmitter is placed in the cradle.

The transmitter is equipped with a battery-saving feature. If the transmitter is inactive for ten minutes, the transmitter will shut itself off (the receiver will then also shut off all outputs). Pressing any of the buttons momentarily before shut-down will reset the ten-minute timer.

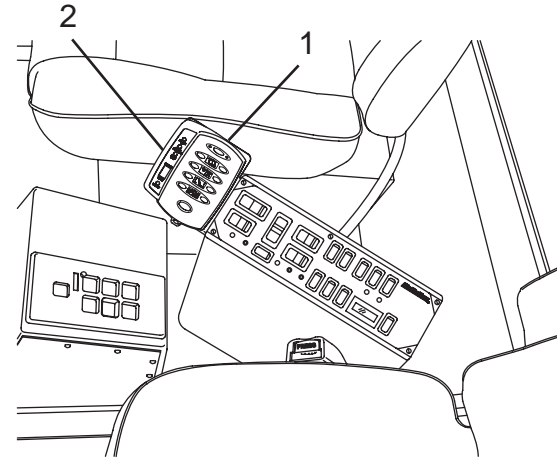

Figure 22

- 2.7.1.1 Control Buttons

**NOTE**

**Transmitter buttons 5, 6, and 7 have alternate functions. The alternate functions are accessed by pressing and holding the green power button after the system is turned on.**

Mixer functions can be operated by the control buttons on the transmitter and docking cradle (Figure 23), as well as the buttons on the cab control console.

No.	Control	Normal Use or Reading
1	DRUM CHARGE Button	Non Functioning
2	Power ON Button	Press to turn the system ON.
	SHIFT SELECT Button (Press and Hold)	Once the system has been activated, pressing and holding the button allows buttons 4, 5, and 10 to operate in the alternate function (lower icon).
3	DRUM DISCHARGE Button <sup>1</sup>	Non Functioning
4	THROTTLE RETARD Button <sup>2</sup> (Primary Function)	Press to retard throttle/drum speed. (See "Adjusting the Throttle Speed" for more information.)
	HOPPER UP/DOWN Button <sup>3</sup> (Alternate Function)	Press to raise or lower the charge hopper. <sup>4</sup>

No.	Control	Normal Use or Reading
5	CHUTE DOWN Button (Primary Function)	Press and hold to lower the discharge chute.
	CHUTE SWING (RIGHT) Button <sup>2</sup> (Alternate Function)	Press and hold to swing the discharge chute to the right.
6	CHUTE LOCK/ UNLOCK Button	Press to engage the chute lock. <sup>3</sup> Press the button again to disengage the chute lock.
7	Power OFF Button	Press to turn the system OFF. The drum will stop if it was rotating when the button was pressed.
8	DRUM STOP Button	Press to stop drum rotation. <sup>3</sup>
9	CHARGE/ DISCHARGE Button (Located on Docking Cradle)	Non Functioning
10	CHUTE UP Button (Primary Function)	Press and hold to raise the discharge chute.
	CHUTE SWING (LEFT) Button <sup>2</sup> (Alternate Function)	Press and hold to swing the discharge chute to the left.
11	THROTTLE ADVANCE Button	Press to advance throttle/drum speed. (See "Adjusting the Throttle Speed" for more information.)

<sup>1</sup> If the DRUM DISCHARGE button is pressed while the drum is rotating in the Charge direction, the drum will slow before rotating in the Discharge direction.

<sup>2</sup> The chassis cruise control must be in the ON position, the parking brake must be applied, and the automatic transmission must be in NEUTRAL.

<sup>3</sup> To activate the alternate function, press and hold the Power ON/SHIFT SELECT button.

<sup>4</sup> The function triggered by the switch will depend on the current state of that function. (Example: If the charge hopper is up, activating the switch will lower it.)

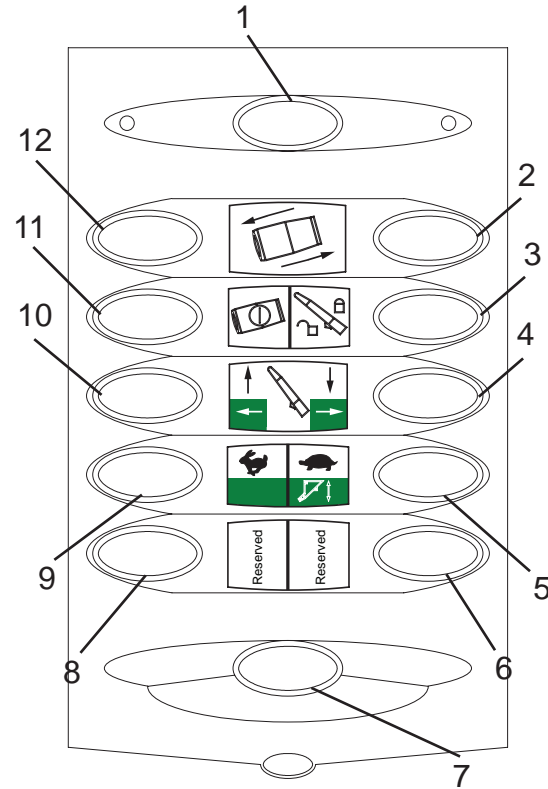

Figure 23

**2.7.2 LED Indicators**

The Battery Low (Figure 24, Item 1) and Active (Figure 24, Item 2) LED indicators on the transmitter are used to indicate the status of the transmitter.

Both of the LED indicators can display one of three colors (red, green, or yellow), and may operate in a solid, or in slow-flash or fast-flash display mode.

The combination of indicators activated, colors, and display modes are used to display transmitter status or display the fault code. (See Diagnostic Codes - Transmitter.)

No.	Control	Normal Use or Reading
1	Battery Low LED	The indicator is ON when the batteries are low. The LED is also used to display diagnostic codes.
2	Active LED	The LED indicates that there is activity between the transmitter and receiver. The LED is also used to display diagnostic codes.
3	BATTERY	The indicator is ON when the transmitter is installed in the docking cradle to indicate that the batteries are being recharged.
4	DRUM STOP	The indicator is ON when the drum rotation is stopped.
5	CHUTE UNLOCKED	The light indicates that the chute lock is unlocked.
6	HOPPER UP	The light indicates that the hopper is in the UP position.

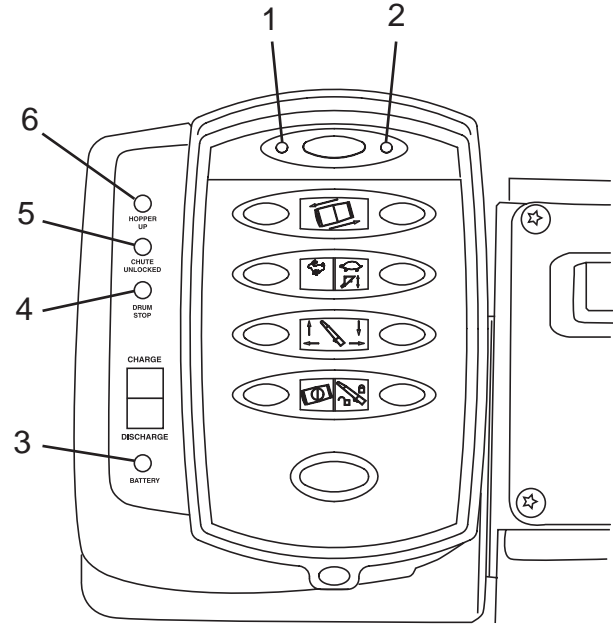

Figure 24

## 2.7.3 OMNEX® Wireless Remote Control (Plug and Play Version)

The OMNEX® Wireless Remote Control system consists of a transmitter, and a receiver that is connected to the mixer electronic control system. The “Plug and Play” version of the OMNEX Wireless Remote Control system uses a receiver (Figure 25, Item 1) that plugs into the rear pendant connector in place of the rear pendant.

A portable transmitter is used to input commands to the mixer system. The transmitter is equipped with a battery-saving feature. If the transmitter is inactive for ten minutes, the transmitter will shut itself off (the receiver will then also shut off all outputs). Pressing any of the buttons momentarily before shut-down will reset the ten-minute timer.

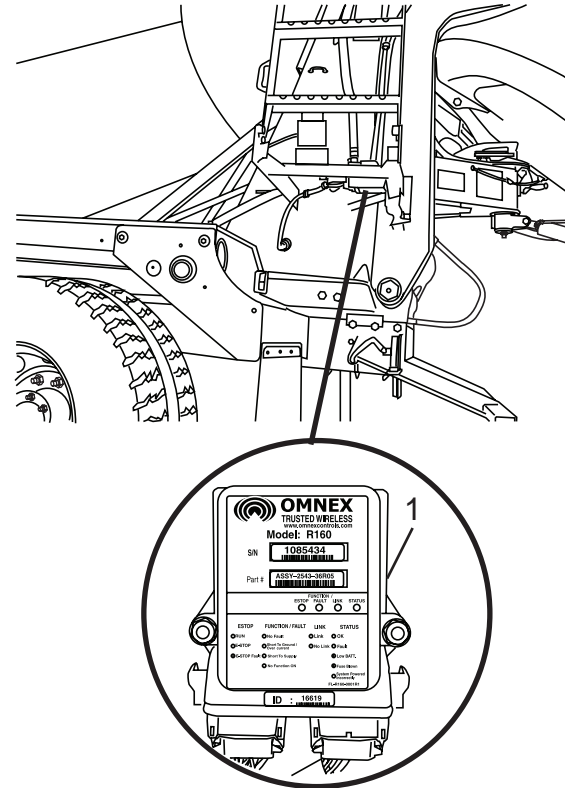

Figure 25

**2.7.4 Transmitter**

• **2.7.4.1 Control Buttons**

Mixer functions can be operated by the control buttons on the transmitter (Figure 26).

No.	Control	Normal Use or Reading
1	POWER ON Button	Press to turn the system ON.
2	CHUTE LOCK Button	Press to lock the chute lock. Press the button again to unlock the chute lock.
3	DRUM DISCHARGE Button <sup>1</sup>	Non Functioning
4	CHUTE DOWN Button	Press and hold to lower the discharge chute.
5	SPARE	Not Used.
6	THROTTLE DOWN Button <sup>2</sup>	Press to retard throttle/drum speed. (See "Adjusting the Throttle Speed" for more information.)
7	POWER OFF Button	Press to turn the system OFF.
8	THROTTLE UP Button <sup>2</sup>	Press to advance throttle/drum speed. (See "Adjusting the Throttle Speed" for more information.)
9	HOPPER Button	Press to raise or lower the charge hopper. <sup>3</sup>
10	CHUTE UP Button	Press and hold to raise the discharge chute.

No.	Control	Normal Use or Reading
11	DRUM CHARGE Button	Non Functioning
12	DRUM START/STOP Button	Press to start drum rotation. Press the button again to stop drum rotation.

<sup>1</sup> If the DRUM DISCHARGE button is pressed while the drum is rotating in the CHARGE direction, the drum will slow before rotating in the DISCHARGE direction.

<sup>2</sup> The chassis cruise control must be in the ON position, the parking brake must be applied, and the automatic transmission must be in NEUTRAL.

<sup>3</sup> The function triggered by the switch will depend on the current state of that function. (Example: If the charge hopper is up, activating the switch will lower it.)

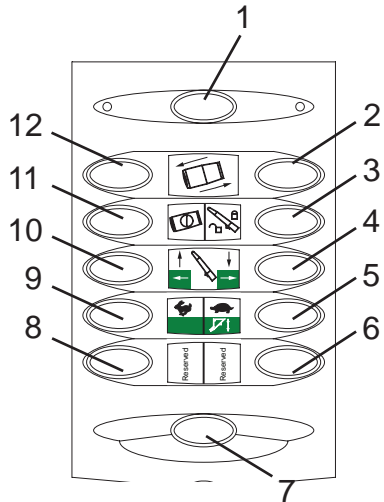

Figure 26

- 2.7.4.2 LED Indicators

The Battery Low (Figure 27, Item 1) and Active (Figure 27, Item 2) LED indicators on the transmitter are used to indicate the status of the transmitter.

Both LED indicators can display one of three colors (red, green, or yellow), and may operate in a solid, or in slow-flash or fast-flash display mode.

The combination of indicators activated, colors, and display modes are used to display transmitter status or display the fault code. (See “Diagnostic Codes - Transmitter.”)

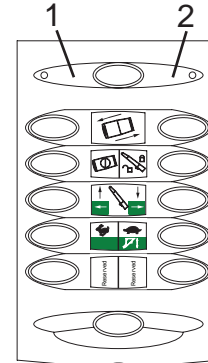

Figure 27

No.	Control	Normal Use or Reading
1	Battery Low LED	The indicator is ON when the batteries are low. The LED is also used to display diagnostic codes.
2	Active LED	The LED indicates that there is activity between the transmitter and receiver. The LED is also used to display diagnostic codes.

## 2.7.5 Cleaning the Transmitter

**⚠ CAUTION**

**Do not clean the transmitter or receiver using high pressure.**

**If water or other liquids get inside the transmitter battery compartment or receiver, immediately dry the unit. Remove the case and allow it to air dry before use.**

**Failure to comply may result in damage to equipment.**

Use a damp cloth to clean the transmitter unit after operation. Remove mud, dirt, concrete, etc. from the transmitter to prevent clogging of buttons.

## 2.7.6 OMNEX<sup>®</sup> Wireless Remote Control (Optional) Troubleshooting

### • 2.7.6.1 Diagnostic Codes – Transmitter

1. The Battery Low (Figure 28, Item 1) and Active (Figure 28, Item 2) LED indicators on the transmitter are used to indicate the status of the transmitter.
2. Both of the LED indicators can display one of three colors (red, green, or yellow), and may operate in a solid, or in slow-flash or fast-flash display modes.
3. The combination of indicators activated, colors, and display modes are used to display transmitter status or display the fault code.

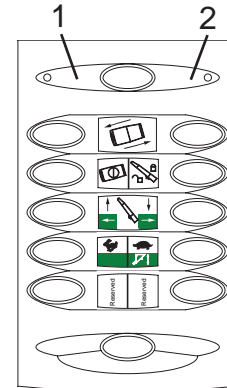

Figure 28

LED Indicator Activity	Status/Fault	Action
Battery Low LED: OFF Active LED: ON – Solid	Occurs whenever a function is pressed. Will also remain on momentarily during power-up.	None required – Normal operation.
Battery Low LED: OFF Active LED: ON – Slow Flash	Transmitter is in download mode.	Turn transmitter OFF and back ON again.
Battery Low LED: OFF Active LED: ON – Fast Flash	Transmitter is in operating mode.	None required – Normal operation.
Battery Low LED: ON – Slow Flash Active LED: ON – Fast Flash	Low battery.	Replace batteries. (See Battery Replacement–Plug and Play Version.) Recharge batteries by placing the transmitter in the docking cradle (cab control box version).
Battery Low LED: ON – Fast Flash (10 seconds) Active LED: OFF	Transmitter failure.	Requires shop service and repair.
Battery Low LED: ON – Slow Flash Active LED: ON – Slow Flash	Stuck button detected.	Turn power off. Depress all buttons several times to free the stuck button. Turn power on and check button functions. If problem cannot be cleared, shop service is required.
On Power Down – Only: Battery Low LED: ON – Slow Flash Active LED: ON – Slow Flash	Unit still under power; a stuck button may be detected.	Turn power off. Depress all buttons several times to free the stuck button. Turn power on and check button functions. If a problem cannot be cleared, shop service is required.
Battery Low LED: ON – Fast Flash Active LED: ON – Fast Flash	Transmitter is in configuration mode.	Requires shop service and repair.
Battery Low LED: ON – Solid Active LED: ON – Solid	Transmitter is downloading ID code.	Requires shop service and repair.

## 2.7.7 Receiver Locations

If the Mixer does not respond to commands from the transmitter, the receiver may need to be accessed to check diagnostic codes.

Depending on the version of the wireless remote installed, the location of the receiver will vary.

**Cab Control Box Version:** The receiver is located in the control box (cab control box) (Figure 29, Item 1).

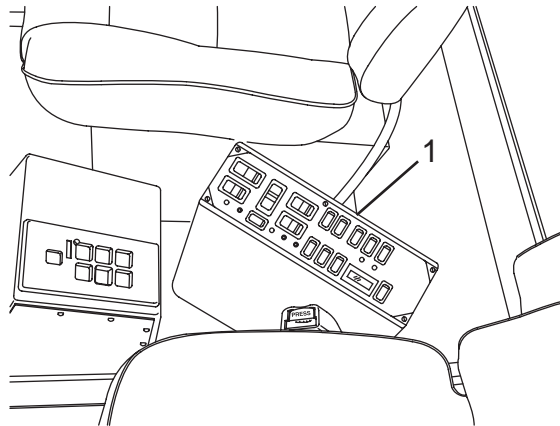

Figure 29

- 2.7.7.1 LED Indicators

LED indicators (Figure 30, Item 1) are used to indicate the operational status of the receiver. The LED indicators are also used to diagnose transmitter problems.

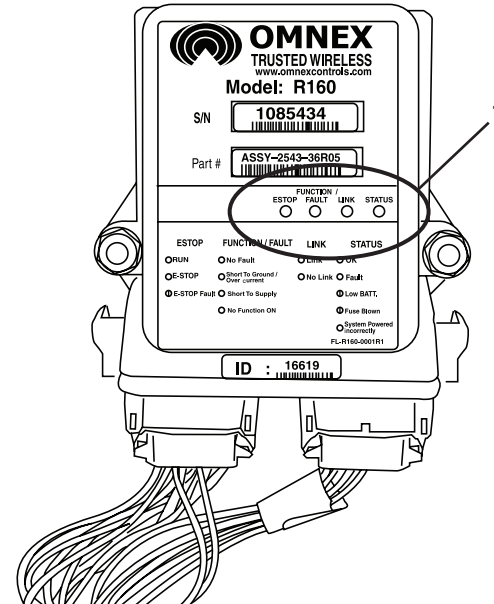

Figure 30

- 2.7.7.2 Normal Operation

LED Indicator Activity	Transmitter Status	Receiver Status
E-STOP: ON – Solid Red FAULT: OFF LINK: ON – Solid Red STATUS: ON – Solid Green	Transmitter: OFF	The receiver is operating properly.
E-STOP: ON – Solid Green FAULT: OFF LINK: ON – Green – Fast Flash STATUS: ON – Solid Green	Transmitter: ON	The receiver is operating properly.
E-STOP: ON – Solid Green FAULT: ON – Solid Green LINK: ON – Green – Fast Flash STATUS: ON – Solid Green	Transmitter: In operation	The receiver is operating properly.
E-STOP: ON – Solid Red FAULT: ON – Solid Green LINK: ON – Solid Red STATUS: ON – Solid Green	Transmitter: OFF	When a latched function is activated when the transmitter is turned off, the FAULT light will stay green. The receiver is operating properly. If the FAULT light is not green, service is required.

- 2.7.7.3 Fault Codes

**NOTE:** In some cases, the LED indicators will vary, depending on whether the transmitter is ON or OFF. See the transmitter status in the “Status/Fault” column in the chart in the pages below.

LED indicators (Figure 31, Item 1) are used to display the receiver fault codes.

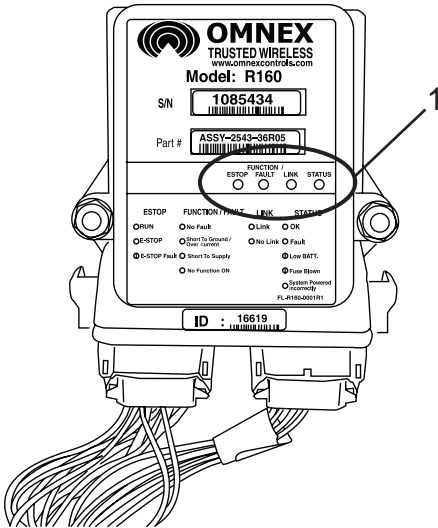

Figure 31

LED Indicator Activity	Status/Fault	Action
E-STOP: ON – Solid Red FAULT: OFF LINK: ON – Solid Red STATUS: ON – Solid Green	Transmitter: ON Receiver is not receiving a signal from the transmitter	Transmitter does not match receiver. Use correct transmitter. If transmitter matches receiver, the receiver requires shop service and repair.
E-STOP: ON – Solid Green FAULT: OFF LINK: ON – Green – Fast Flash STATUS: ON – Green – Slow Flash	Transmitter: ON A low battery condition has been detected	Replace batteries (Plug and Play Version). (See Battery Replacement – Plug and Play Version.) Recharge batteries (cab control box version). If fault code still displays after the batteries have been replaced, shop service and repair is required.
E-STOP: ON – Red – Slow Flash FAULT: OFF LINK: ON – Green – Fast Flash STATUS: ON – Solid Red	Transmitter: ON Short detected in E-STOP circuit	Requires shop service and repair.
E-STOP: ON – Solid Green FAULT: ON – Solid Red LINK: ON – Green – Fast Flash STATUS: ON – Solid Red	Transmitter: ON A short to ground or excessive current load has been detected	Requires shop service and repair.
E-STOP: ON – Solid Red FAULT: ON – Red – Slow Flash LINK: ON – Red – Fast Flash STATUS: ON – Solid Red	Transmitter: ON E-STOP output not properly connected	Requires shop service and repair.
E-STOP: ON – Solid Red FAULT: ON – Red – Slow Flash LINK: ON – Solid Red STATUS: ON – Solid Red	Transmitter: OFF A wiring short to the battery has been detected	Requires shop service and repair.

LED Indicator Activity	Status/Fault	Action
E-STOP: ON – Solid Red FAULT: OFF LINK: ON – Solid Red STATUS: ON – Solid Red	Transmitter: OFF Internal fault detected in receiver	Requires shop service and repair
E-STOP: ON – Solid Red FAULT: OFF LINK: ON – Solid Red STATUS: ON – Red – Slow Flash	Transmitter: OFF Blown fuse detected	Replace fuse. (See Fuse Functions.)
E-STOP: ON – Solid Green FAULT: OFF LINK: ON – Red – Fast Flash STATUS: ON – Red – Fast Flash	Transmitter: ON Set-up mode failure	Requires shop service and repair
E-STOP: ON – Solid Red FAULT: ON – Red – Slow Flash LINK: ON – Solid Red STATUS: ON – Alternating Red/Green – Fast Flash	Transmitter: OFF Receiver powered incorrectly	Requires shop service and repair

## 3.0 Mixer Options

### 3.1 Hydraulic Fold-Over Chute

The hydraulic fold-over toggle switch (Figure 32, Item 1) enables the operator to fold or unfold the fold-over chute (Figure 32, Item 2) using a hydraulic cylinder.

#### WARNING

**Do not let persons, other than the driver, handle the chutes, unfold the foldover, and/or remove extension, or stow and secure the extensions for transit. Keep hands away from chute hardware where the chutes connect. Never stand in the path of the chute as it is being unfolded or while in use. Failure to follow the warnings concerning chute safety may result in serious injury.**

#### CAUTION

**Do not move the vehicle with the fold-over chute extended and chute extensions installed. Driving the vehicle with chute extensions installed may cause damage to equipment.**

To unfold the chute:

1. Position the chute so that there is sufficient room behind the chute. Lock the main chute using the manual chute lock or the optional chute air lock.
2. Remove the fold-over retaining chain.
3. Press and hold the fold-over toggle switch (Figure 32, Item 1) until the fold-over chute (Figure 32, Item 2) is fully seated against the main chute. Release the switch.

To fold the chute:

1. Press and hold the fold-over toggle switch (Figure 32, Item 1) until the fold-over chute (Figure 32, Item 2) is fully seated against the main chute. Release the switch.
2. Secure the fold-over chute to the main chute with the retaining pin.
3. Stow and lock the main chute using the manual chute lock or the optional chute air lock.

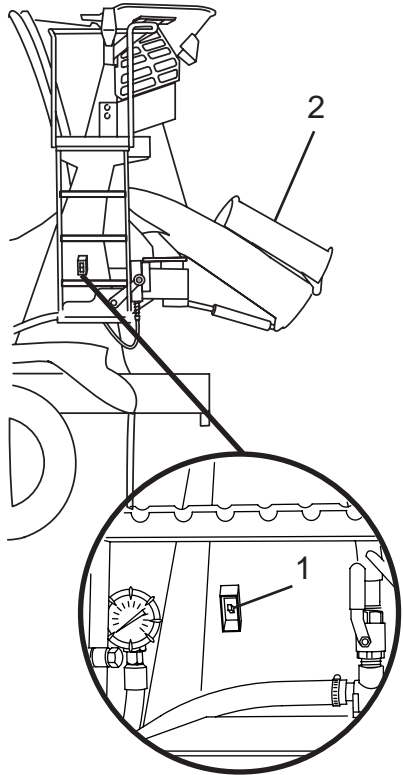

Figure 32

### 3.2 Chute Assist

The fold-over chute assist operates on a manual pulley to lower the fold-over chute into position.

To unfold the chute:

1. Unlatch the securing hook.
2. Grip the fold-over chute using the correct hand-holds (Figure 33).
3. Slowly lower the chute into operation position (Figure 34).

To fold the chute:

1. Grip the fold-over chute using the correct hand-holds (Figure 34).
2. Slowly raise the chute into stored position (Figure 35).
3. Latch the securing hook.

**NOTE:** The securing hook needs to be latched on the hand hold of the fold-over chute.

#### **WARNING**

The chute assist has pinch points between the main chute and the fold-over chute. Keep hands away from chute hardware where chutes connect. Keep hands away from the pulley system.

Failure to comply may result in serious personal injury or death or damage to equipment.

**WARNING**

Do not let persons, other than the driver, handle the chutes, unfold the foldover, and/or remove extension, or stow and secure the extensions for transit. Keep hands away from chute hardware where the chutes connect. Never stand in the path of the chute as it is being unfolded or while in use. Failure to follow the warnings concerning chute safety may result in serious injury.

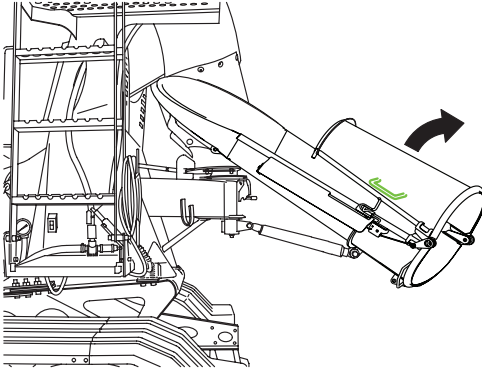

Figure 33

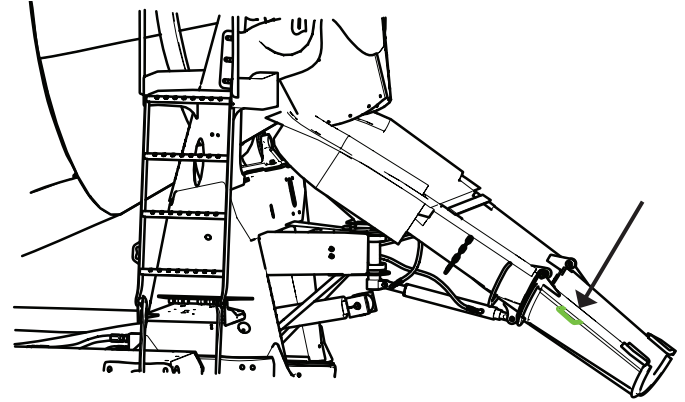

Figure 34

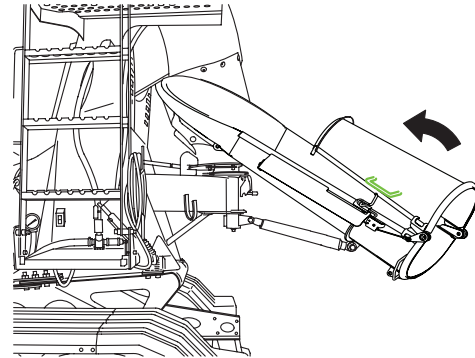

Figure 35

### 3.3 Hydraulic Chute Swing

The hydraulic chute swing option (Figure 36, Item 1) allows the operator to move the discharge chute from the rear pendant.

#### **WARNING**

**Stay clear of chutes when the power chute swing is in operation.**

**Failure to follow the warnings concerning chute safety may result in serious personal injury or property damage.**

To engage the chute swing option:

1. Release the manual chute lock (Figure 36, Item 2).
2. Release the chute air lock. (See Cab Pendant Controls or Rear Pendant Controls for more information.)
3. Press the CHUTE SWING LEFT or RIGHT buttons on either the cab control or rear pendant to engage the chute swing drive. Release the button when the chute reaches the desired position. (See Cab Pendant Controls or Rear Pendant Controls for more information.)

#### **WARNING**

**Optional air chute lock is intended for use only on the job site. The manual chute lock should always be engaged during transport. Excessive wear or injury may result due to improper usage.**

4. Engage the chute air lock.

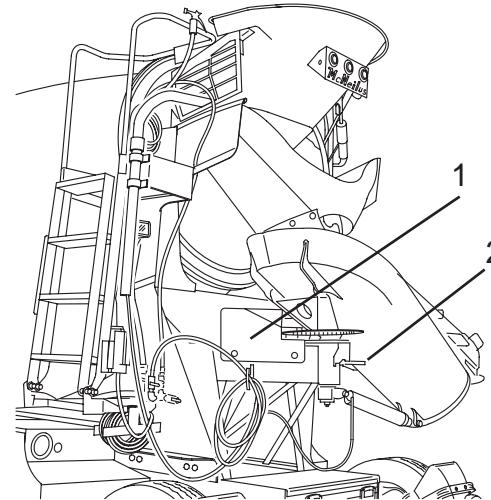

Figure 36

### 3.4 Discharge Chute Vibrator Valve

When the chute vibrator valve (Figure 37, Item 1) is placed in the OPEN position, air pressure is supplied to the chute vibrator. This assists stiff slump concrete to flow down the chute.

#### **CAUTION**

**Operating the chute vibrator without concrete in the chute may cause damage to equipment.**

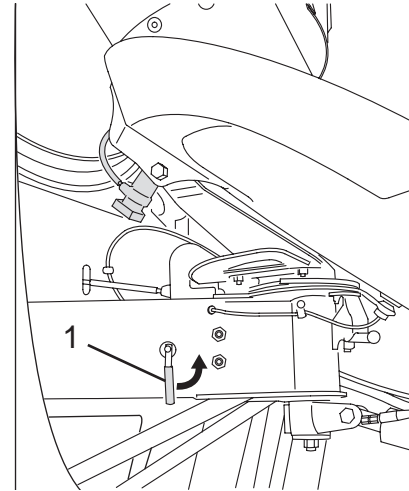

Figure 37

### 3.5 Chute Blockers

Discharge chute blockers are available in two styles—Shute Shutter™ (Figure 38, Item 1) or “Rock Stopper” (Figure 39, Item 1).

Both types prevent concrete or other debris from dropping off the main chute during transport. The chute blocker will automatically open when the fold-over chute is unfolded, and will close automatically when the fold-over chute is folded.

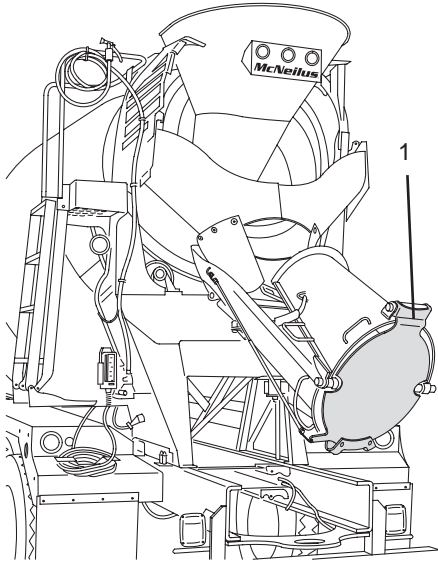

Figure 38

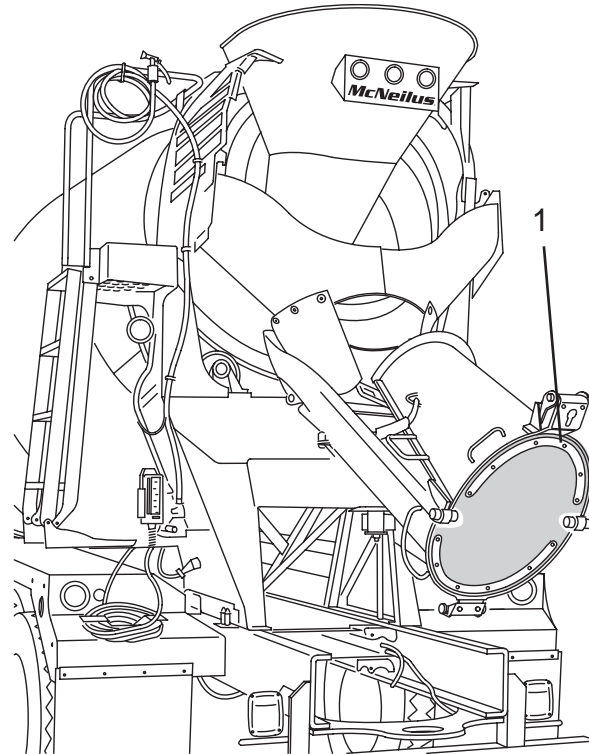

Figure 39

### 3.6 Foldover Stop

The optional foldover chute stop provides an additional margin of safety from pinch hazards when unfolding the foldover chute.

As the chute is unfolded, the foldover chute stop tab (Figure 40, Item 1) will make contact with the main chute, preventing the chute from slamming down against the main chute.

When the chute is raised, the foldover chute stop will automatically release.

#### **WARNING**

**Remove hands, fingers, and any obstructions from the gap between the main and foldover chutes before releasing the foldover stop.**

**Failure to comply could result in serious personal injury.**

To release the foldover chute stop:

1. Support the fold-over chute (Figure 40, Item 2).
2. Depress the handle (Figure 40, Item 3) until the stop tab (Figure 40, Item 1) clears the main chute, and lower the fold-over chute.

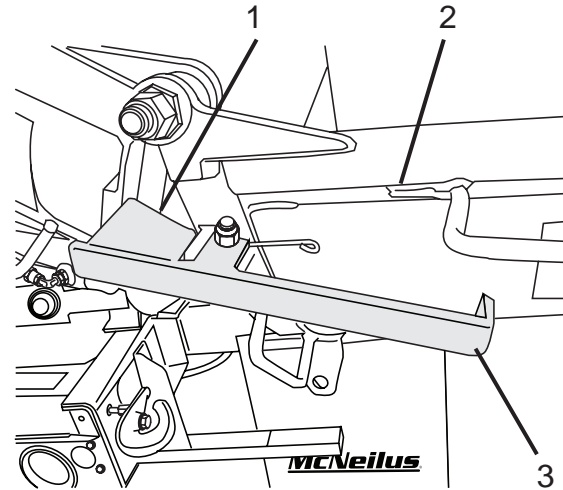

Figure 40

### 3.7 Composite Chute Extension

#### **⚠ DANGER**

Composite chute extensions are flammable. Do not expose to an open flame or a temperature exceeding 220°F (104°C). Burning chute extensions produce toxic smoke/fumes during combustion. Serious personal injury or death could occur.

#### **⚠ DANGER**

Do not repair metal or composite chute extensions. Serious personal injury or death could occur.

#### **⚠ CAUTION**

Do not use more than three chute extensions. Do not combine the use of metal and composite chute extensions during operational use. Failure to comply could cause damage to the equipment.

The composite chute extensions are lighter weight than metal chute extensions, but function the same. Composite and metal

chute extensions should never be used in combination.

### 3.8 Flip-Up Charge Hopper

#### **⚠ CAUTION**

A raised hopper may cause overhead clearance problems. Always lower the flip-up hopper when not in use.

Failure to lower the hopper may result in damage to equipment.

The flip-up charge hopper (Figure 41, Item 1) allows the charge hopper to be moved up to allow improved discharge of low slump concrete.

The flip-up charge hopper can be controlled either from the cab controls, or from the rear of the Mixer from the drum control or optional rear pendant.

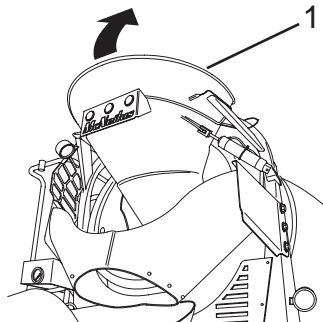

Figure 41

### 3.9 SAT (Swing Away Throat) Charge Hopper

The “Swing Away Throat” charge hopper (Figure 42, Item 1) allows the lower section of the charge hopper to move back (away from the drum opening). This allows improved discharge of low slump concrete without raising the entire charge hopper.

The “Swing Away Throat” charge hopper can be controlled either from the cab controls, or from the rear of the Mixer from the drum control or optional rear pendant.

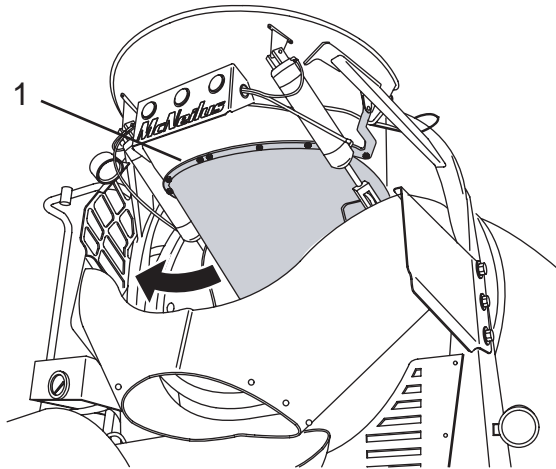

Figure 42

### 3.10 Concrete Slump Meter

**NOTE**

**The location of the concrete slump meter may vary.**

The concrete slump meter (Figure 43, Item 1) indicates the slump of the concrete by reading the hydraulic pressure required to rotate the drum. This pressure remains reasonably constant for a wide range of load sizes, the only requirement being that the mixing blades be fully covered.

The hydraulic pressure required to rotate the drum at a specific slump will vary because of different drum size, age, and drive ratios. This requires the slump meter to be calibrated for each Mixer.

**NOTE**

**The concrete should be thoroughly mixed before a slump reading is taken from the slump meter.**

The slump meter is calibrated by positioning pointers (Figure 43, Item 2) that are marked in inches of slump around the circumference of the hydraulic gauge. The pointers indicate the pressure that is required to rotate the drum at a given slump (See Setting the Mechanical Concrete Slump Meter.)

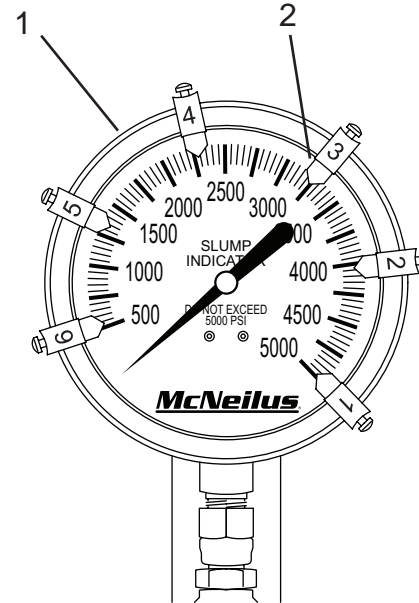

Figure 43

### 3.10.1 Setting the Mechanical Concrete Slump Meter

To calibrate the slump meter:

1. Load the drum with the normal full load of concrete at a slump that is less than the driest point you wish to read on your indicator, for example, 3".

#### NOTE

**To accurately calibrate the slump meter, the concrete must mix for at least 40 revolutions before setting the pointer.**

2. Add water to the concrete until a slump reading of 3" is obtained when the concrete is fully mixed. Check the slump using a standard slump cone test.
3. Run the Mixer in the CHARGE direction with the truck engine at idle rpm. The drum must be mixing when reading the indicator.
4. Loosen the locking screw (Figure 44, Item 1), and move the 3" indicator (Figure 44, Item 2) to match the tip of the indicator needle. Tighten the locking screw.
5. Add water and test for 4", 5", and 6" of slump in the same manner.

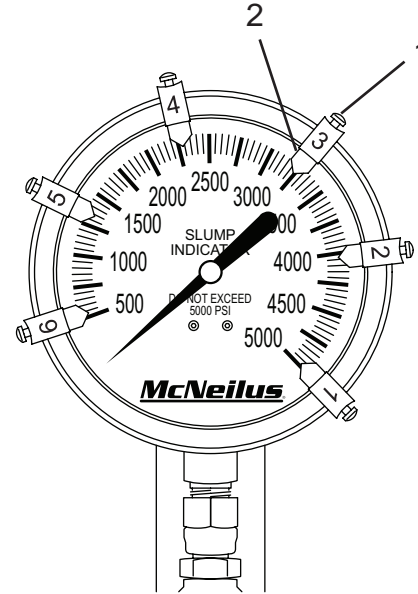
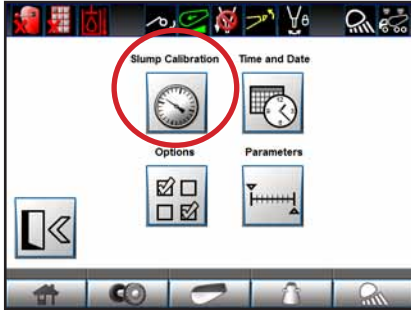

Figure 44

## 3.10.2 Setting the Digital Concrete Slump Meter

Digital slump meter must be calibrated individually on each truck upon delivery and periodically thereafter.



1. Touch the screen at the slump calibration line you want to adjust the reading for a given slump (Figure 45, Item 1).
2. Adjust either the “slump inches” or the “slump pressure” as required (Figure 45, Items 2 and 3).
3. Touch the “+” sign to add additional slump indication points (Figure 45, Item 4).
4. Touch the BACK button the save (DO NOT touch the HOME button) (Figure 45, Item 5).

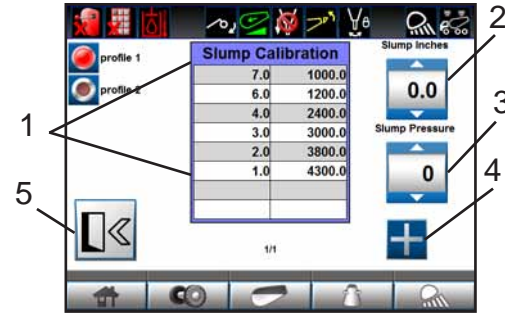

Figure 45

### 3.10.2.1 Adding a Slump Point

1. Enter the slump calibration screen. Touch the “+” sign to add additional slump indication points (Figure 46, Item 1).

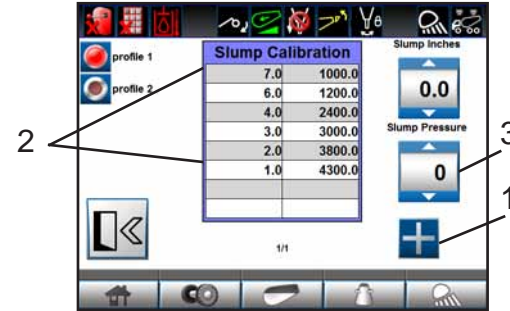

Figure 46

- Use the arrows or key in the desired slump point (Slump Inches). Touch the check mark button to save selection (Figure 47).

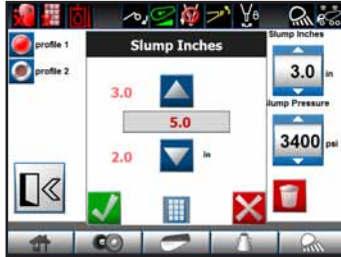

Figure 47

- The slump point will appear in the slump list (Figure 48, Item 2). Touch the slump line you want to calibrate.
- Touch the slump pressure button (Figure 48, Item 3).
- Use the arrows or key in the desired slump pressure (Figure 48). Press the check mark button to save selection.

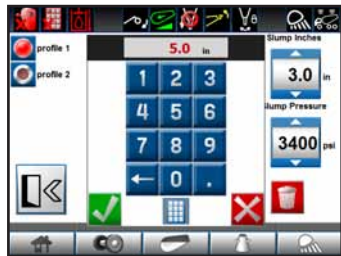
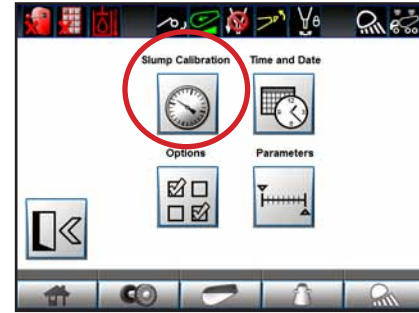

Figure 48

- 3.10.2.2 Deleting a Slump Point



- Touch the line of the slump point you wish to delete (Figure 49, Item 1). The line will be highlighted.
- Touch the DELETE button (Figure 49, Item 2).

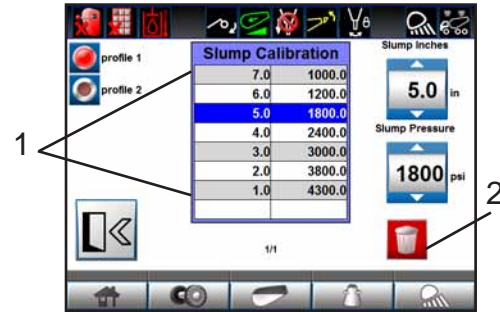

Figure 49

### 3.11 Trimble® Mobile Solutions Crosscheck System

#### NOTE

The Trimble® Mobile Solutions Crosscheck System will need to be activated before use. Contact Trimble® Support at 877-883-4367.

The Trimble® Mobile Solutions Crosscheck System (Figure 50, Item 1) is a GPS-based tracking and dispatch system. This system allows the dispatcher to continuously track the mixer status without using voice communications.

Refer to the information supplied with the Mixer for operating and troubleshooting information.

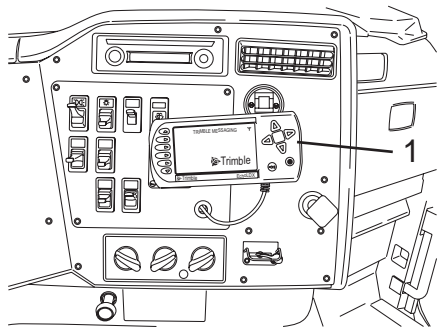

Figure 50

### 3.12 Safety Vision System

#### WARNING

The Safety Vision System should be used in conjunction with both rear view mirrors. Do not watch the monitor exclusively while backing the truck.

The monitor can be used as an aid in lane changing and monitoring traffic behind the truck. Viewing the monitor should be limited while driving.

Failure to use the Safety Vision System as intended may result in death or serious personal injury.

The Safety Vision System uses a video camera and monitor to provide a view of the area behind the Mixer, and can be an aid when backing the truck.

Refer to the information supplied with the Mixer for operating and troubleshooting information.

### 3.13 Eagle Eye™ Electronic Obstacle Detection System

 **WARNING**

**The Eagle Eye™ Electronic Obstacle Detection System should be used in conjunction with both rear view mirrors. Do not rely on the obstacle detection system exclusively while backing the truck or when changing lanes.**

**Failure to use the obstacle detection system as intended may result in death or serious personal injury.**

The Eagle Eye™ Electronic Obstacle Detection System uses a series of sensors positioned around the truck to detect vehicles or other large obstacles around the truck. If obstacles are detected, an LED indicator on the display module will turn red.

Refer to the information supplied with the Mixer for operating and troubleshooting information.

### 3.14 Central Lubrication Systems

Mixers may be equipped with one of several central lubrication systems. These systems allow mixer components to be lubricated from a central station.

Some systems have a manually-operated pump usually mounted in the cab.

**NOTE**

**Lincoln Quicklube® system shown; other systems are similar.**

Other central lubrication systems consist of a powered pump and reservoir unit (Figure 51, Item 1) mounted in the rear pedestal. This system can be set to automatically lubricate mixer components at pre-determined intervals.

Each lubrication system has unique features and operating controls. Refer to the information supplied with the Mixer for specific operating, maintenance, and troubleshooting information.

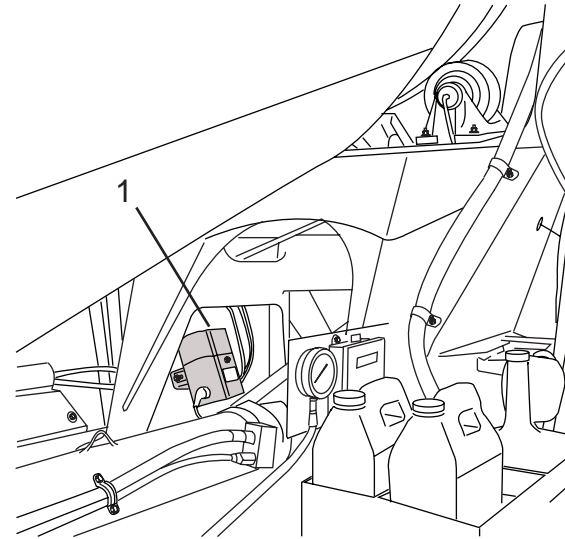

Figure 51

**NOTE**

**The mounting location for the central lubrication system may vary depending on options and truck configuration.**

The central lubrication may be equipped with an indicator light (Figure 52, Item 1). This light can be used to indicate operation and troubleshooting codes. Refer to the information supplied with the Mixer for specific information.

Each lubrication system has unique features and operating controls. Refer to the information supplied with the Mixer for specific operating, maintenance, and troubleshooting information.

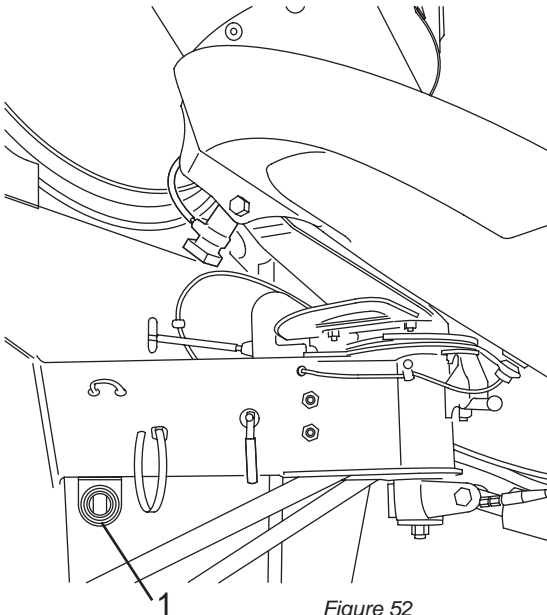

Figure 52

## 4.0 Chassis Options

### 4.1 Pusher Axles

The auxiliary axle down force is controlled by regulated air pressure to the axle suspension air springs. The regulated air pressure is preset at the factory to a common pressure setting. Determine the actual regulated air pressure by driving the vehicle over a truck scale at the various weights the vehicle will be operated at up to the GVWR as shown on the Final Stage Manufacturer Label located on the driver's side cab doorjamb (see the Foreword). Adjust the regulated air pressure according to the auxiliary axle manufacturer's pressure/weight chart located in the cab information packet supplied with the vehicle. The air pressure gauge is located in the cab of the vehicle and may also be located outside of the cab.

Always follow your company's policies and procedures when adjusting the air pressure. If you have any questions, call McNeilus Parts and Service branches at 888-686-7278.

#### NOTE

The following information is for auxiliary axles installed by McNeilus Truck and Manufacturing, Inc. Refer to chassis manufacturer information for axle installed by the chassis manufacturer or a third party.

Pusher axle(s) (Figure 53, Item 1) are located in front of the rear drive axle.

Auxiliary axles use an UP/DOWN switch (labeled PUSHER) to control the lower and lift function. The UP/DOWN switch is located on the digital control display in the cab (Figure 54).

The auxiliary axle down force is controlled by regulated air pressure to the axle suspension air bags. The regulated air pressure is preset at the factory. The air pressure of the axle is displayed on an air gauge located in the truck cab. The air gauge may also be mounted outside of the cab.

To change the air pressure of an auxiliary axle, refer to the service manuals for your truck. Always follow your company's policies and procedures when adjusting the air pressure. If you have any questions, call McNeilus Parts and Service at 888-686-7278.

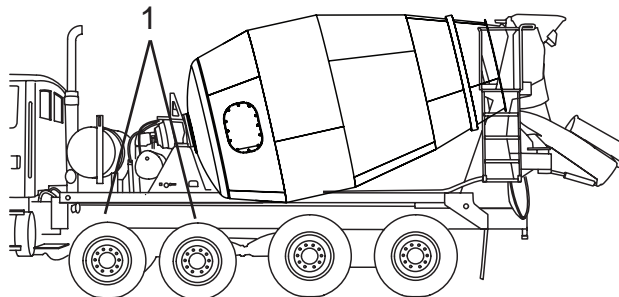

Figure 53

**4.1.1 Raising or Lowering Pusher Axle**

**NOTE:** Auxiliary axles may raise when the truck is placed in reverse.

**NOTE**

Lower the auxiliary axle(s) only when your load requires an auxiliary axle to distribute load weight.

**NEVER** lower auxiliary axle(s) when the truck is moving, or when the mixer is empty.

The pusher axle air pressure is preset at the factory. Only your service department is authorized to adjust air pressure.

**NOTE**

All McNeilus installed pusher axles are designed to lift when the truck is in reverse gear.

1. Bring the truck to a complete stop and set the park brake. (Refer to the Operator's Manual supplied by the chassis supplier for all parking procedures.)
2. Touch the AXLE function button on the bottom row of the display home screen (Figure 54, Item 1).

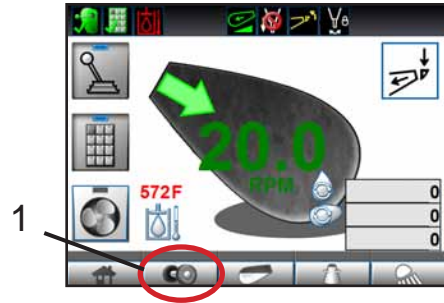

Figure 54

3. AXLE operation screen appears; touch the button for the desired lift axle operation (raise or lower) (Figure 55, to raise and to lower).

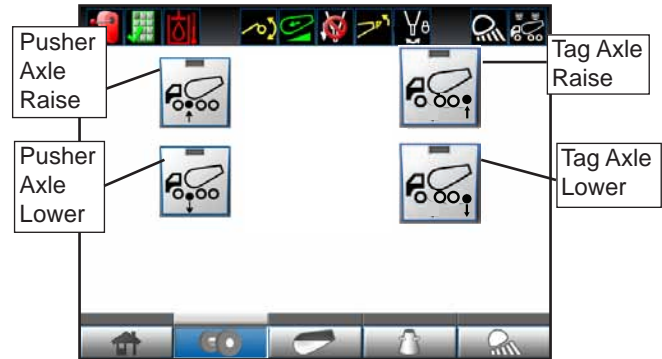

Figure 55

## 5.0 Control Functions

### 5.1 Hopper Function

The Hopper function button is located on the cab keypad or the rear pendant only. To activate the Hopper function, press the HOPPER function button on either the cab keypad or the rear pendant (Figure 56, Item 1).

**NOTE:** The Hopper UP or DOWN icons will display on the touch screen monitor.

The button indicator will illuminate when mode is selected. Indicator light is red when hopper is up and green when hopper is down.

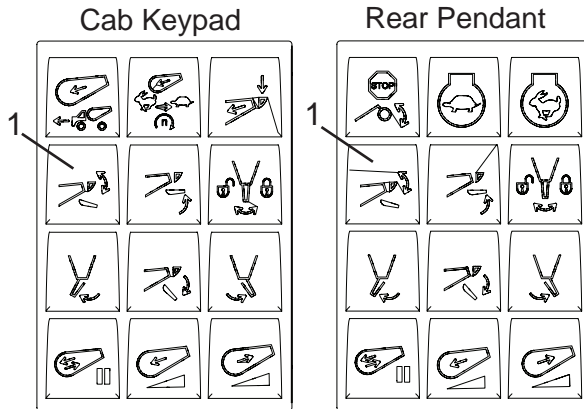
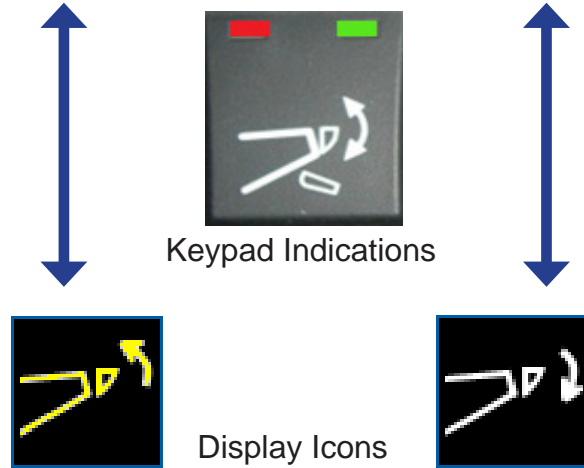

Figure 56

Hopper UP

Hopper DOWN



## 5.2 Chute Lock Function

The Chute Lock function button is located on the cab keypad or the rear pendant only. To activate the Chute Lock function, press the CHUTE LOCK function button on either the cab keypad or the rear pendant (Figure 57, Item 1).

**NOTE:** The Chute Lock Unlocked or Locked icons will display on the touch screen monitor.

The button indicator will illuminate when mode is selected. Indicator light is red when unlocked and green when locked.

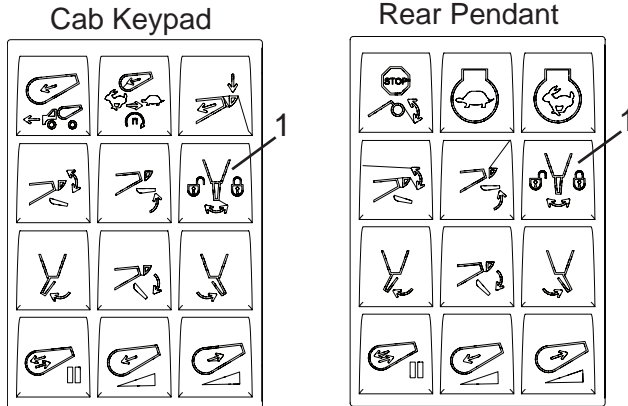
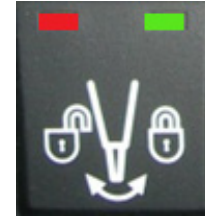
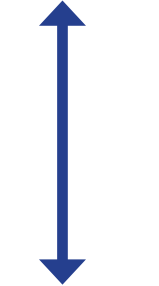

Figure 57

Chute  
UNLOCKED

Chute  
LOCKED



Keypad Indications



Display Icons



### 5.3 Chute Raise/Lower and Swing Functions

The Chute Raise/Lower or Swing function buttons are located on the cab keypad or the rear pendant only (Chute Swing is an optional feature). To activate the Chute Raise/Lower or Swing functions, press the appropriate function buttons on either the cab keypad or the rear pendant (Figure 58). Press and hold the desired function button until desired movement is achieved.

Indicator lights will illuminate green only when pressed.

Ref.	Function
1	Chute UP
2	Chute DOWN
3	Chute Swing LEFT
4	Chute Swing RIGHT

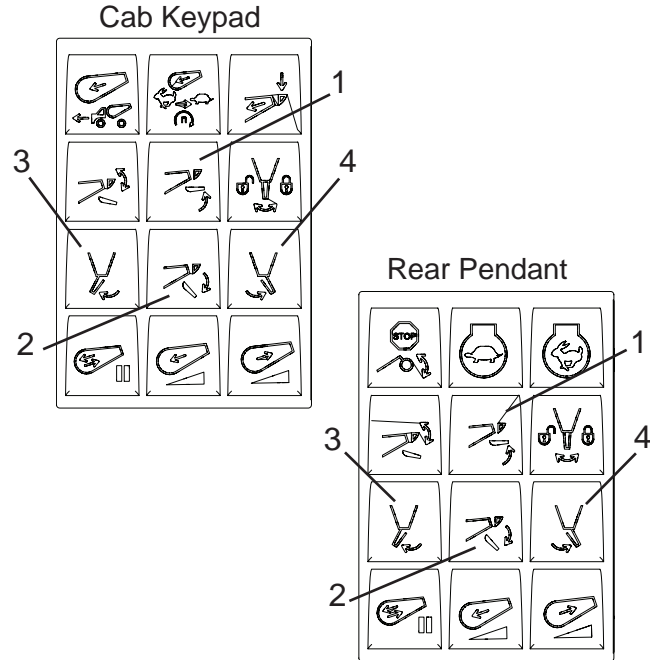

Figure 58

### 5.4 Work Lighting Functions

The touch screen monitor displays information necessary for operating the work lighting (if equipped).

1. Touch the LIGHT function button on the bottom row of the touch screen home screen (Figure 59, Item 1).
2. Touch the button for the selected light function.
  - a. The button will illuminate if output is turned on (all indicators shown on in Figure 60).

Ref.	Function	Description
1	Perimeter Lights	Fender mounted perimeter lights.
2	Work Lights	Rear pedestal work lights.
3	Strobe Lights	All locations of strobe lights.
4	Work Lights (In Reverse)	Work lights turn on when Mixer is placed in reverse.
5	Camera Light	Camera light option currently may not be available. This button allows user manually to go to the camera screen; otherwise, the camera will come on when in Reverse.
6	Strobe Lights (In Reverse)	Strobe lights turn on when Mixer is placed in reverse.

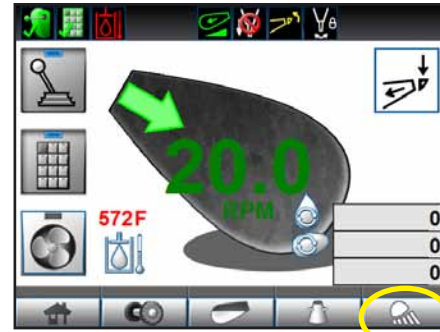

Figure 59

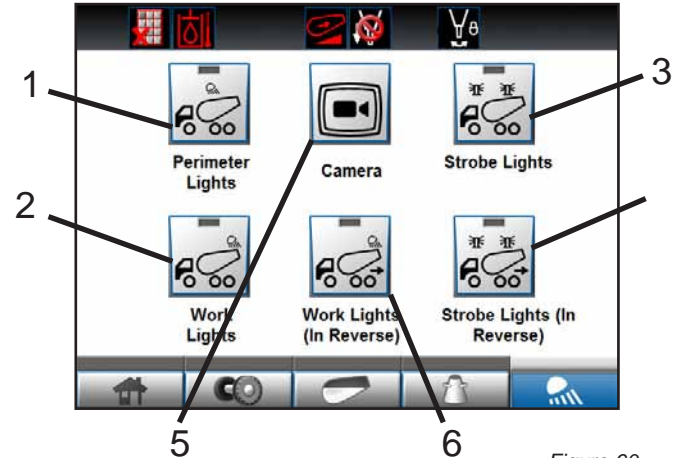

Figure 60

## 5.5 Add Water Function

### 5.5.1 Manual Water Injection System

Water can be added to the drum by opening the water injection ball valve (Figure 61, Item 1) located at the rear of the Mixer.

Some Mixers may be equipped with an optional valve (Figure 61, Item 3). This valve will automatically close when the handle is released.

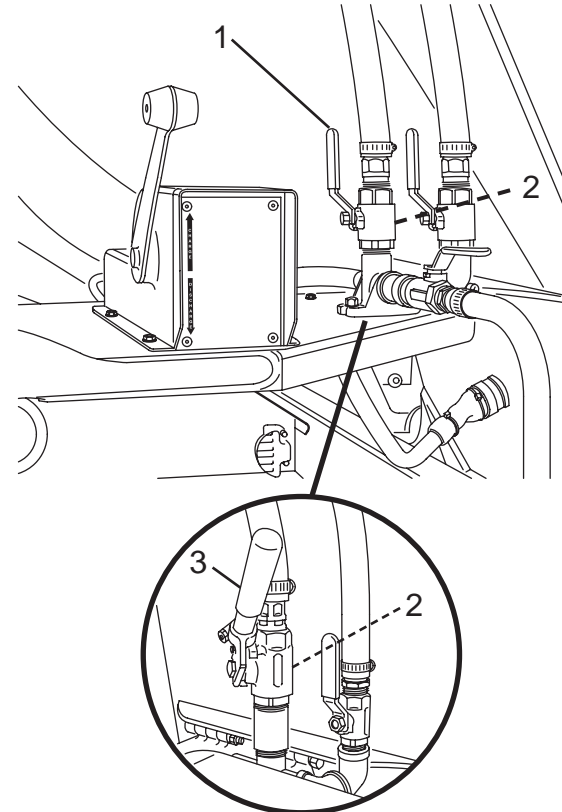

Figure 61

### **WARNING**

**Never allow the water from the tank to drain onto a public sidewalk or roadway. Water may cause the sidewalk or roadway to become slippery. Always drain the water system at a location designated by the job site manager or in compliance with your company policy.**

**Failure to comply may result in serious personal injury or death.**

Both valves may be equipped with a drain option. This feature automatically drains the water from the hose(s) beyond the valve, through a small hole at the rear of the valve (Figure 60, Item 2).

### 5.5.2 Remote Water Injection System

This system allows the operator to add water while remaining in the cab by activating the ADD WATER button in the touch screen display.

To add water:

1. Open the water injection ball valve (Figure 62, Item 1).

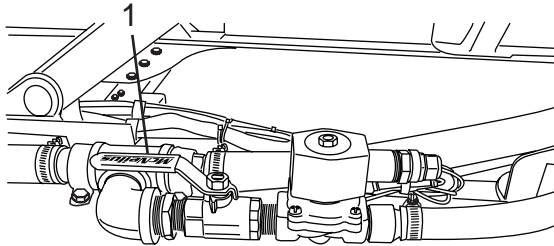

Figure 62

2. Touch the slump button at the bottom of the home screen.
3. Edit the amount of gallons to be added (Figure 63, Item 1).
4. Touch the ADD WATER button (Figure 63, Item 2).

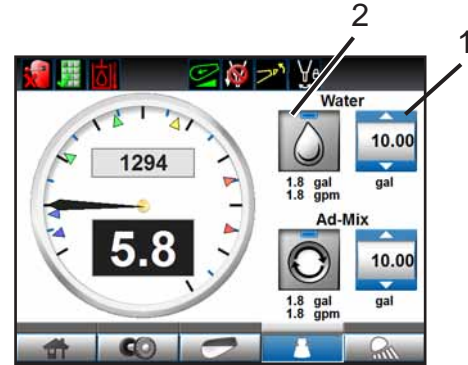

Figure 63

5. Once the desired amount of water has been added, the system will shut off the electronic water valve.
6. Close the water injection ball valve (Figure 62, Item 1).

## 6.0 Water Tanks

### 6.1 Water Tank Safety

#### **WARNING**

##### **IMPORTANT ALUMINUM AND STEEL WATER TANK INFORMATION.**

1. Inspect water tank on a daily basis for any damage including, but not limited to, dents, gouges in metal, or leaks.
2. Do not weld on or repair water tank. Instead, replace water tank with a new OEM water tank.
3. Never pressure test an empty water tank. Only pressure test a full water tank.
4. Never remove pressure regulator or pressure safety valve from tank.
  - If regulator or safety valve is defective, it must be replaced before Mixer is put into service.
5. Do not pressurize water tank beyond its working pressure.
  - If pressure exceeds the working pressure, immediately depressurize water tank and replace pressure regulator and pressure safety valve.

#### **WARNING**

##### **CONTINUED**

6. Never drive the truck with the water tank pressurized.
  - Depressurize water tank prior to transit to or from job site.
  - Water tank should be pressurized only when being used.
7. Never modify water tank in any way.
8. Immediately replace safety decals with McNeilus decals if decals are missing or difficult to read.
9. Refer to the McNeilus Operator's Manual or contact McNeilus at 1-888-686-7278 if you have questions or require assistance.

## 6.2 Water Tank Operation

### 6.2.1 Introduction

Your mixer may be equipped with a pressurized water tank. This tank is used to add water to a concrete mix, and to provide a source of water pressure for washing down the chutes and the drum. Air pressure from the truck's brake system is used to provide pressure to the tank. Use these instructions for the safe operation and inspection of all McNeilus, Oshkosh, and London pressurized water tanks.

If your mixer is equipped with a non-pressurized water tank (a system that uses a water pump to provide pressure), refer to the instructions provided with the mixer.

## 6.2.2 Daily Operation



### • 6.2.2.1 Tank Integrity

**At the start of each shift:**

- **Inspect Interior:** Drain the tank of water and use a flashlight to look into the tank through the fill opening. Look for signs of corrosion on the inside of the tank which may indicate that the tank has been weakened and is in need of replacement.
- **Inspect Exterior without Pressure:** If the interior inspection indicates that the tank is in good condition, fill

the tank with water and inspect the exterior of the tank thoroughly for signs of leaks. Inspect the filler neck and fill opening. Look for signs of damage. Look for cracks in the weld joints or seams. Check that all fastening hardware is tight and undamaged. Inspect fittings for signs of damage, cracks, or looseness.

- **Inspect Exterior with Pressure:** If there are no signs of exterior leakage, pressurize the tank and repeat the inspection.
- **Depressurize Tank:** Release the pressure in the tank as soon as you are finished inspecting and before moving the truck.

**Replace Defective Tank:** Water tanks with any leak or significant signs of internal or external damage or corrosion should be replaced. **DO NOT ATTEMPT TO REPAIR.**

### • 6.2.2.2 Pressure Regulator Valve

**Inspect Pressure Regulator:** The pressure regulator is used to reduce the air brake system pressure to a pressure that is safe to be used in the water tank. It must be undamaged and in proper working order. Look and listen for signs of leaking. Ensure that the valve and associated hoses and fittings are undamaged.

**Adjust Pressure to Correct Setting:** Many pressure regulators are set at the factory and cannot be adjusted. If your water tank has an adjustable regulator, set it to 50 psi. When setting the regulator, always begin by turning the

adjusting knob counterclockwise first to reduce the pressure slightly. Then turn it clockwise slowly to bring the pressure up to the correct setting. Never continue to turn the valve past the correct setting.

**Replace Defective Regulator Valve:** Any water tank with a damaged or missing pressure regulator valve must be removed from service immediately. Do not pressurize the tank until a functioning pressure regulator valve has been installed.

- **6.2.2.3 Pressure Relief Valve**

**Inspect the Relief Valve:** The pressure relief valve is a safety device that will release air or water from the tank if it is inadvertently pressurized over the relief setting. The relief setting on most water tanks is set at the factory and cannot be adjusted. Identify the pressure relief valve and ensure that it has not been damaged or tampered with.

**Replace Defective Relief Valve:** Any water tank with a damaged or missing pressure relief valve must be removed from service immediately. Do not pressurize the tank until a functioning pressure relief valve has been installed.

### 6.2.3 Daily Operation

The water tank is designed to be used during stationary operation at the yard or the job site only. It is not necessary or beneficial for the tank to be pressurized while driving, and a pressurized tank is an added hazard in the event of a crash or a rollover.



### 6.2.4 Vehicle Handling Characteristics

Safe operation of any vehicle is the responsibility of the driver. Concrete trucks have a significantly higher rollover tendency than other types of vehicles due to a higher center of gravity and the affect of concrete shifting in the drum. The water tank is also a fluid load that can increase the rollover tendency if the truck is driven with the water tank partially full. To reduce the risk of rollover, only drive a loaded truck (concrete in the drum) with the water tank either completely full or completely empty. Avoid making sharp turns at excessive speeds and other abrupt maneuvers.

In the event of a rollover or crash, an unbelted person is significantly more likely to become injured or die than a person wearing a seat belt. **ALWAYS WEAR YOUR SEAT BELT.**

### 6.3 Water Tank Decal Identification

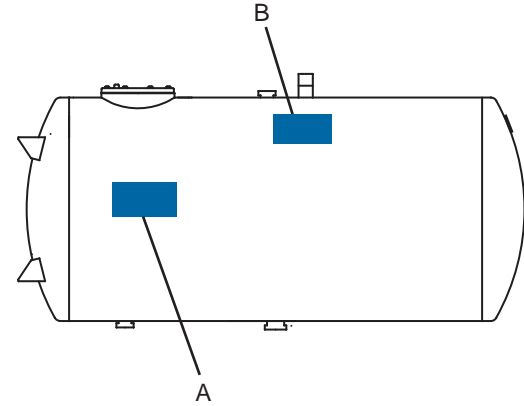

(Side Tank Mount)

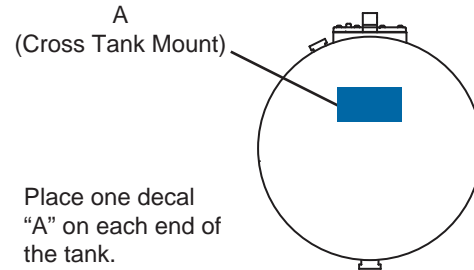

Place one decal "A" on each end of the tank.

## 6.4 Water Tank Mounting Positions

The water tank(s) can be mounted in one of several locations, depending on the Mixer configuration and options.

## 6.5 Standard Water Tank

Mixers are equipped with at least one water tank to provide water for adjusting the slump and for cleaning. Additional water tanks are optional.

### **WARNING**

**NEVER** drink the water from a water tank. The water tank may contain residue from chemicals used to modify concrete properties. Drinking the water from a tank may cause serious internal injury or death.

### **WARNING**

**NEVER** modify the water tank(s) in any way. Serious personal injury or death may occur.

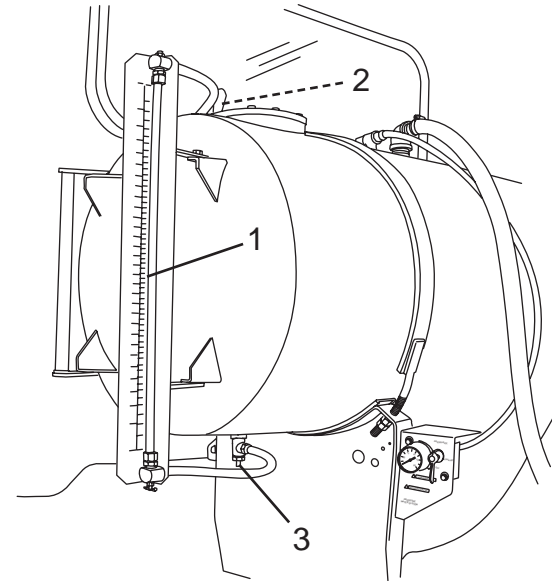

Figure 64

### 6.5.1 Single Sight Gauge

The water tank sight gauge (Figure 64, Item 1) allows the operator to view the water level in the tank. The sight gauge is equipped with isolator valves (Figure 64, Items 2 and 3) that can isolate the sight gauge from the pressurized water tank in the event the sight gauge tube is broken.

## 6.6 Split Water Tank (Optional)

Some Mixers can be equipped with a split water tank. This tank provides a main compartment for water and a smaller compartment (usually 15 or 25 gallon [57 or 95 liter] capacity) that may be used to hold a chemical solution.

### 6.6.1 Dual Sight Gauges

On Mixers equipped with split water tanks, the water tanks will have two sight gauges. One sight gauge will indicate the level of the chemical tank (Figure 65, Item 1). This tank can have a capacity of 15 or 25 gallons (57 or 95 liters).

The other sight gauge (Figure 65, Item 2) will indicate the level of the main water tank.

The sight gauges are equipped with isolator valves that can isolate the sight gauges from the pressurized water tank in the event a sight gauge is broken. Valves are located at the top and bottom of the sight gauges.

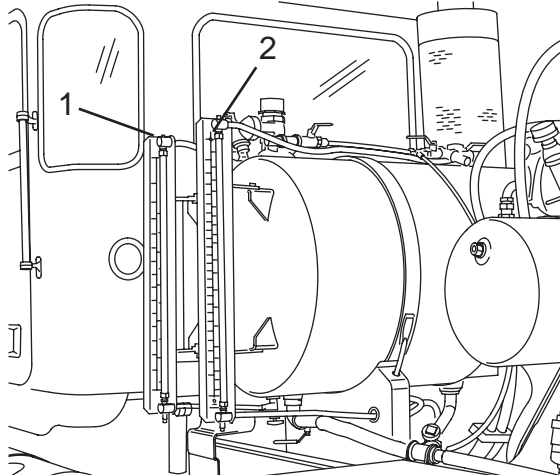

Figure 65

## 7.0 Water System - Pressurized

### **WARNING**

**Never drive the truck with the water tank pressurized.**

**Serious personal injury or death may occur.**

### 7.1 Depressurizing the Water Tank

1. Turn air pressure control valve to EXHAUST position (Figure 66, Item 1). Make sure the gauge (Figure 66, Item 2) reads 0 psi (0 kPa).

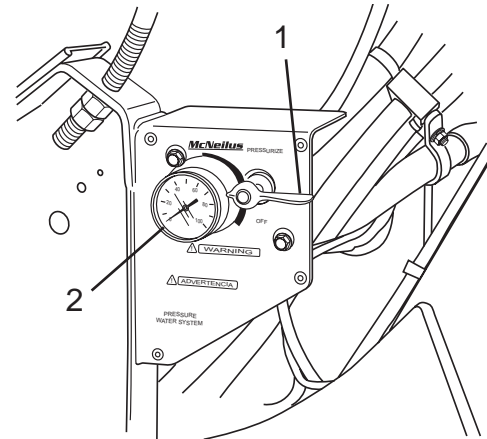

Figure 66

2. After pressure in the water tank has been completely exhausted, turn the air pressure control valve to the OFF position (Figure 67, Item 1).

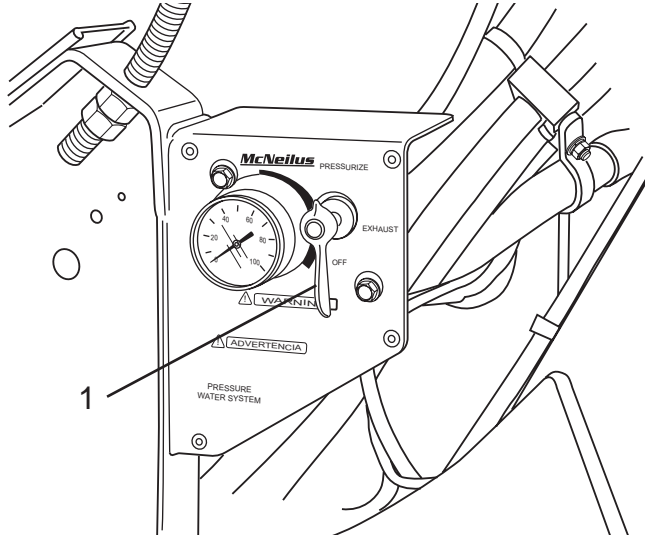

Figure 67

## 7.2 Pressurizing the Water Tank

1. Open the air valve (Figure 68, Items 1 or 2) of the tank compartment to be pressurized. If equipped with an optional split tank, each compartment will have its own valve.

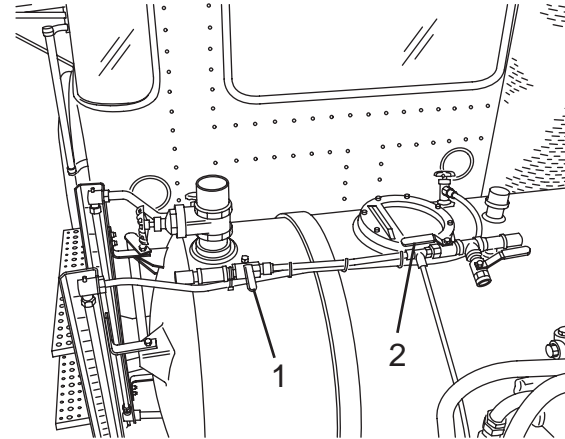

Figure 68

### **WARNING**

**Never pressurize an empty water tank.  
Serious personal injury or death may occur.**

**WARNING**

Never pressurize water tank in excess of 55 psi (380 kPa). If pressure exceeds 55 psi (380 kPa), depressurize the water tank immediately and adjust or replace the air regulator valve.

Serious personal injury or death may occur.

2. Turn air pressure control valve to the PRESSURIZE position (Figure 69, Item 1). The water tank will be pressurized from the chassis air system. The air gauge (Figure 69, Item 2) will indicate the pressure in the water tank. The pressure must not exceed 55 psi (380 kPa).

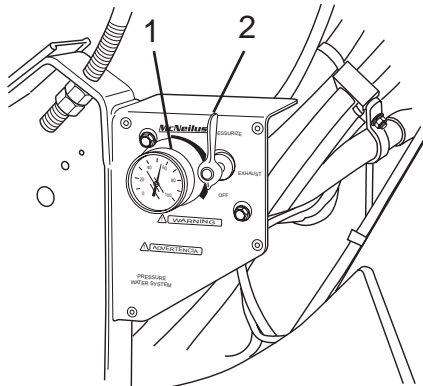

Figure 69

### 7.3 Draining the Water System

**WARNING**

Never allow the water from the tank to drain onto a public sidewalk or roadway. Water may cause the sidewalk or roadway to become slippery. Always drain the water system at a location designated by the job site manager or in compliance with your company policy.

Failure to comply may result in serious personal injury or death.

**CAUTION**

Be sure to drain the water tank, hoses, and pipes when operating in temperatures below freezing.

Failure to drain the system may cause damage to equipment.

**NOTE**

**When draining the chemical tank, the contents should be drained into a properly marked container.**

**The container should be stored for reuse, or the contents should be disposed of in compliance with all applicable regulations.**

When operating in temperatures below freezing, the water system must be drained after every use.

1. Depressurize the water tank(s).
2. Remove the water tank drain plug(s), or open the main tank (Figure 70, Item 5) and chemical tank (if equipped) drain valves (Figure 70, Item 3).
3. Open the main tank (Figure 70, Item 4) and chemical (if equipped) sight glass isolator valves (Figure 70, Item 2).
4. Open the sight glass drain valves (Figure 70, Item 1).

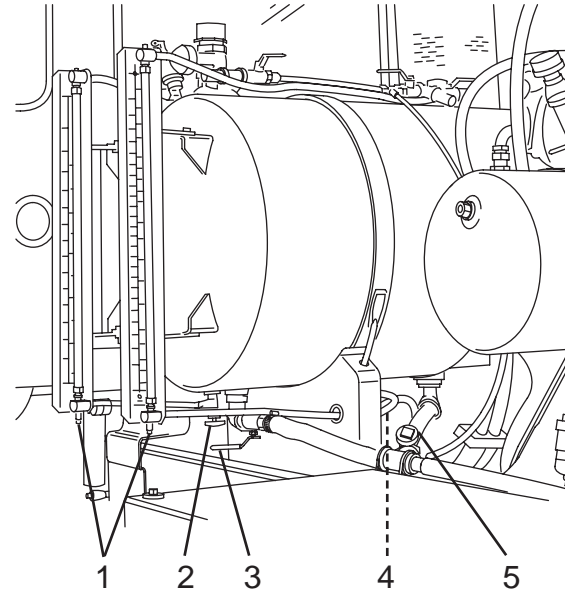

Figure 70

5. Open wash-out hose valve (Figure 71, Item 3) at the rear of the Mixer and allow water to drain.
6. Open drum wash-out valve (if equipped) (Figure 71, Item 1), and add-water valve (Figure 71, Item 2) and allow water to drain.
7. Open all valves controlling water flow to optional equipment such as water meters.

### NOTE

**Apply thread sealant tape or thread sealant compound to the drain plug threads before installation.**

8. When no more water comes from the tank drain(s) and water nozzles, install the water tank drain plug(s). Tighten the plug until snug.
9. Close the sight glass drain valves.
10. Close the drum wash-out valve (if equipped) (Figure 71, Item 1) and add-water valve (Figure 71, Item 2).
11. Pressurize water tank(s) to approximately 10—20 psi (69—138 kPa). Allow water to drain from wash-out hose.
12. Depressurize the water tank(s).

### NOTE

**Inspect hoses for low points that may retain water, even after the system has been drained.**  
**If a low spot is noted, have your service department reposition hoses to eliminate the low spot.**

13. Open the drain petcock located at the lowest point in the supply hose (Figure 71, Item 4).

### NOTE

**If possible, drain and remove wash-out hose(s), and store hose(s) in the cab.**

14. Open all water valves and make sure the water tank is depressurized.

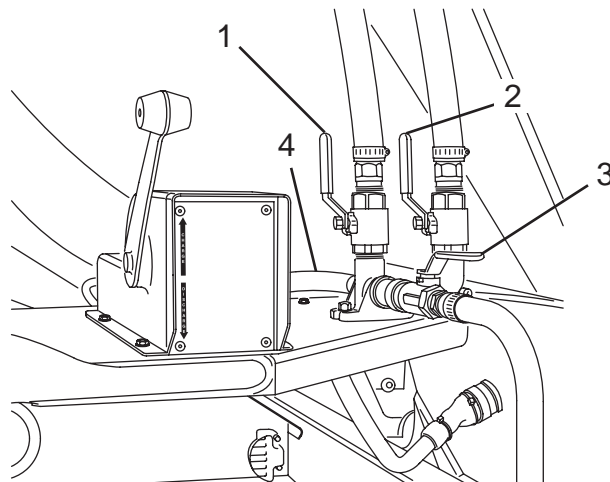

Figure 71

## 7.4 Filling the Main Tank

1. Depressurize the water tank.
2. Place the water supply hose in the water tank flopper valve (Figure 72, Item 1).

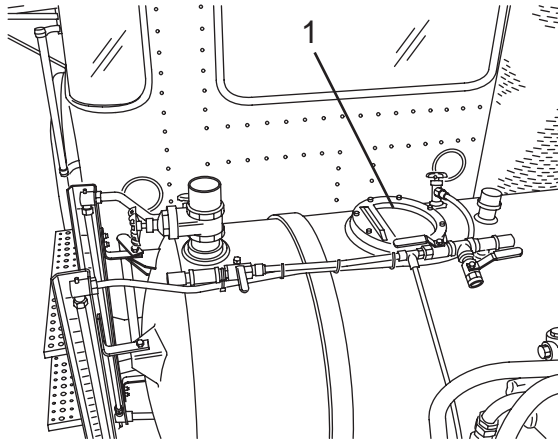

Figure 72

3. Open the water supply valve and fill the water tank.
4. Close the water supply valve.
5. Remove the supply hose from the valve.
6. Pressurize the water tank.

### **WARNING**

If damaged, corroded, or leaking, the water tank must be replaced with an OEM water tank from McNeilus Truck and Manufacturing, Inc.

Failure to maintain water tanks may result in serious personal injury or death.

### **CAUTION**

Do not weld on or near the water tank. If the water tank requires structural repair, contact McNeilus Truck and Manufacturing, Inc. at 888-686-7278.

Attempting to repair the water tank will void your warranty. Failure to comply may result in damage to equipment.

7. Inspect the water system for leaks. If leaks are noticed, repair the leaks before putting the Mixer into service.
8. Depressurize the water tank before leaving for the job site.

## 7.5 Filling the Chemical Tank (Split Tank Option)

### NOTE

Check with the batch plant operator for the proper type and amount of chemical required for the load.

The chemical tank is used to store additives needed to change the properties of the concrete. These additives may include plasticizers or retardants.

1. Depressurize the water tank.
2. Open the chemical tank gate valve (Figure 73, Item 1) and add the chemical through the inlet (Figure 73, Item 2).
3. Close the chemical tank gate valve.
4. Pressurize the water tank.

### WARNING

If damaged, corroded, or leaking, the water tank must be replaced with an OEM water tank from McNeilus Truck and Manufacturing, Inc.

Failure to maintain water tanks may result in serious personal injury or death.

### CAUTION

Do not weld on or near the water tank. If the water tank requires structural repair, contact McNeilus Truck and Manufacturing, Inc. at 888-686-7278.

Attempting to repair the water tank will void your warranty. Failure to comply may result in damage to equipment.

5. Inspect the water system for leaks. If leaks are noticed, repair the leaks before putting the Mixer into service.
6. Depressurize the water tank before leaving the job site.

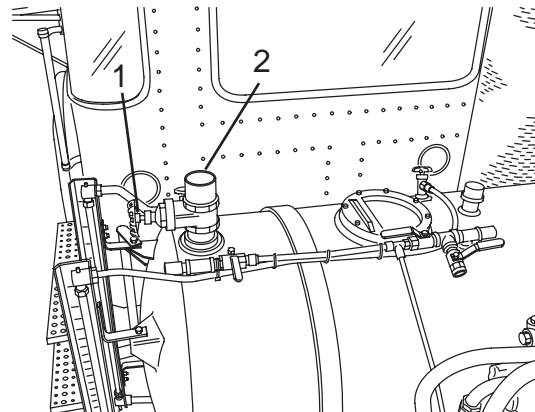

Figure 73

## 8.0 Water System - Pump

### **⚠ WARNING**

**Never attempt to repair the water tank. Never apply a weld procedure to a water tank. Replace water tank immediately if damaged. Failure to comply may cause serious injury or death.**

The tank (Figure 74, Item 1) is not pressurized at any time. The water is drawn from the tank and pressurized by the air-powered diaphragm pump (Figure 74, Item 2).

The tank is equipped with one or more breathers (Figure 74, Item 3) that must be kept clean to ensure adequate water flow.

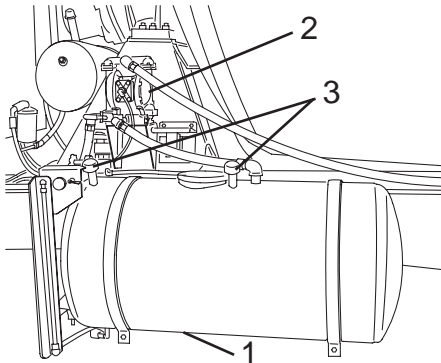

Figure 74

## 8.1 Pump Operation - Steel or Aluminum Tanks

The pump is powered by compressed air supplied by the chassis air compressor.

To operate the pump:

1. Start the truck and check to make sure the air pressure gauge is supplied with 100 psi (689 kPa) of pressure.
2. Close the purge valve (Figure 75, Item 1) at the pump inlet.
3. Open the main tank ball valve (Figure 75, Item 2) or chemical tank ball valve (Figure 75, Item 3) (if equipped) for the desired tank/water source.

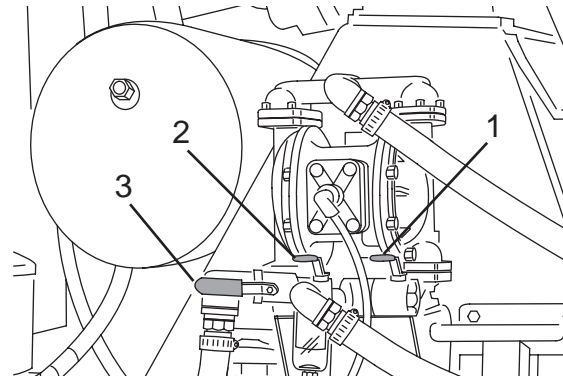

Figure 75

**WARNING**

**NEVER** pressurize a composite water tank.  
**NEVER** modify water tank in any way.  
Pressurizing a composite tank or modifying the tank may cause serious injury or death.

**NOTE**

Trucks equipped with composite tanks will have the air pressure control valve mounted directly on the pump assembly.

**NOTE**

Turn off pump when not in use.

4. Turn the air pressure control valve (Figure 76, Item 1) to the PRESSURIZE position to start the pump.

To stop the pump, turn the air pressure control valve (Figure 76, Item 1) to the OFF position.

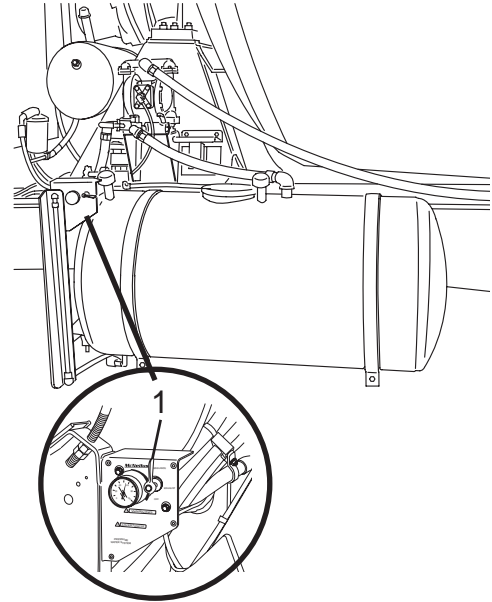

Figure 76

5. Open the upper wash-out valve (Figure 77, Item 1), “Add Water” valve (Figure 77, Item 2), or lower wash-out valve (Figure 77, Item 3) to activate the desired function.

### CAUTION

**Be sure to drain the water system after each use when operating in temperatures below freezing.**

**Failure to drain the system may cause damage to equipment.**

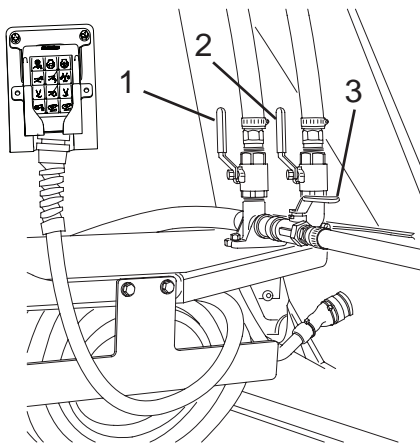

Figure 77

## 8.2 Filling the Water Tank

1. Turn the pump off by turning the air pressure control valve to the OFF position.
2. Place the water supply hose in the water tank flopper valve (Figure 78, Item 1) and fill the tank.

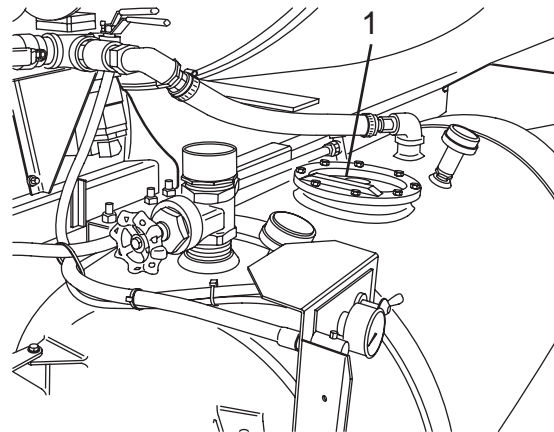

Figure 78

3. Close the water supply valve.
4. Remove the supply hose from the flopper valve.

**WARNING**

If damaged, corroded, or leaking, the water tank must be replaced with an OEM water tank from McNeilus Truck and Manufacturing, Inc.

Failure to maintain water tanks may result in serious personal injury or death.

**CAUTION**

**Do not weld on or near the water tank. If the water tank requires structural repair, contact McNeilus Truck and Manufacturing, Inc. at 888-686-7278.**

**Attempting to repair the water tank will void your warranty. Failure to comply may result in damage to equipment.**

5. Inspect the water system for leaks. If leaks are noticed, repair the leaks before putting the Mixer into service.

### 8.3 Filling the Chemical Tank - Steel or Aluminum Tanks (Split Tank Option)

**NOTE**

**Check with the batch plant operator for the proper type and amount of chemical required for the load.**

The chemical tank is used to store additives needed to change the properties of the concrete. These additives may include plasticizers or retardants.

1. Turn the pump off by turning the air pressure control valve to the OFF position.
2. Open the chemical tank gate valve (Figure 79, Item 2) and fill the chemical through the inlet (Figure 79, Item 1).
3. Connect a water supply hose to the inlet (Figure 79, Item 1) and fill tank.
4. Close the water supply valve.
5. Remove the supply hose from the tank.

**⚠ WARNING**

If damaged, corroded, or leaking, the water tank must be replaced with an OEM water tank from McNeilus Truck and Manufacturing, Inc.

Failure to maintain water tanks may result in serious personal injury or death.

**⚠ CAUTION**

Do not weld on or near the water tank. If the water tank requires structural repair, contact McNeilus Truck and Manufacturing, Inc. at 888-686-7278.

Attempting to repair the water tank will void your warranty. Failure to comply may result in damage to equipment.

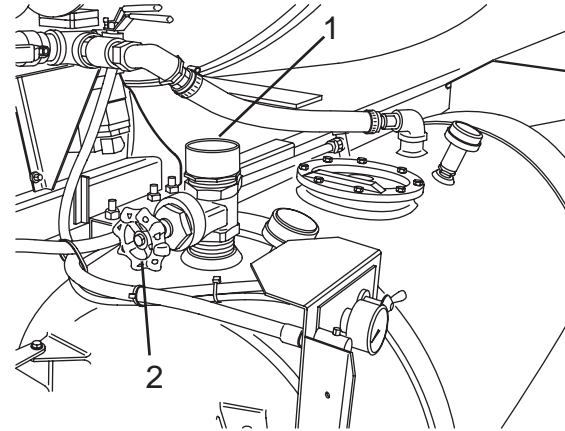

Figure 79

Inspect the water system for leaks. If leaks are noticed, repair the leaks before putting the Mixer into service.

## 8.4 Draining the Water System

### WARNING

Never allow water to drain onto a public sidewalk or roadway. Water may cause the sidewalk or roadway to become slippery. Always drain the water system at a location designated by the job site manager, or in compliance with your company policy.

Failure to comply may result in serious personal injury or death.

### CAUTION

Be sure to drain the water system after each use when operating in temperatures below freezing.

Failure to drain the system may cause damage to equipment.

### NOTE

When draining the chemical tank, the contents should be drained into a properly marked container.

The container should be stored for reuse, or the contents should be disposed of in compliance with all applicable regulations.

When operating in temperatures below freezing, the water system must be drained after each use.

1. Park the truck on a firm, level surface to allow proper drainage.

### NOTE

The purge valve should be angled down slightly to permit proper drainage.

If the valve is not positioned properly, have your service department reposition the valve/tee fitting assembly.

2. Open the main tank ball valve (Figure 80, Item 2) and chemical tank ball valve (Figure 80, Item 1) (if equipped).

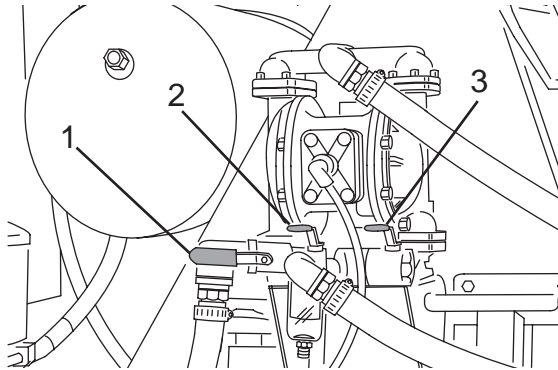

Figure 80

3. Remove the water tank drain plug(s) (Figure 81, Items 3 and 5), or open the drain valve(s) (if equipped).
4. Open the main tank (Figure 81, Item 4) and chemical tank (if equipped) (Figure 81, Item 2) sight glass isolator valves.
5. Open the sight glass drain valve(s) (Figure 81, Item 1).

### NOTE

**Apply thread sealant tape or thread sealant compound to the drain plug threads before installation.**

6. When no more water comes from the tank drain(s), install the water tank drain plug(s) (Figure 81, Items 3 and 5). Tighten the plug(s) until snug.
7. Close the sight glass drain valve(s) (Figure 81, Item 4).

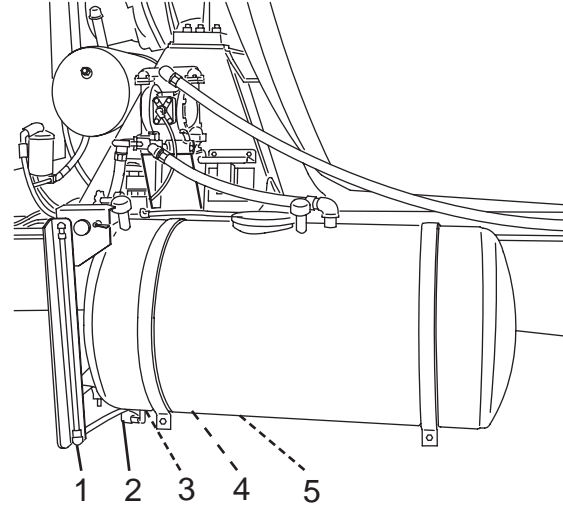

Figure 81

8. Start the truck and check to make sure the air pressure gauge is supplied with 100 psi (689 kPa) of pressure.
9. Turn the pump on by turning the air pressure control valve to the PRESSURIZE position.

10. Close the main tank ball valve (Figure 82, Item 2) and chemical tank ball valve (Figure 82, Item 1) (if equipped).
11. Open the purge valve (Figure 82, Item 3).

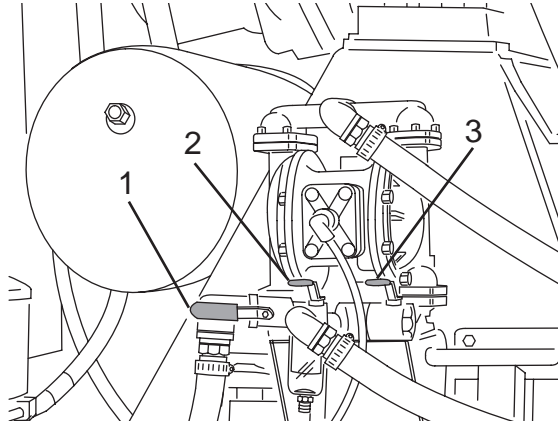

Figure 82

12. Open wash-out hose valve (Figure 83, Item 3) at the rear of the Mixer and allow water to drain.
13. Open wash-out valve (Figure 83, Item 1) and add-water valve (Figure 83, Item 2) and allow water to drain through wash-out hose.

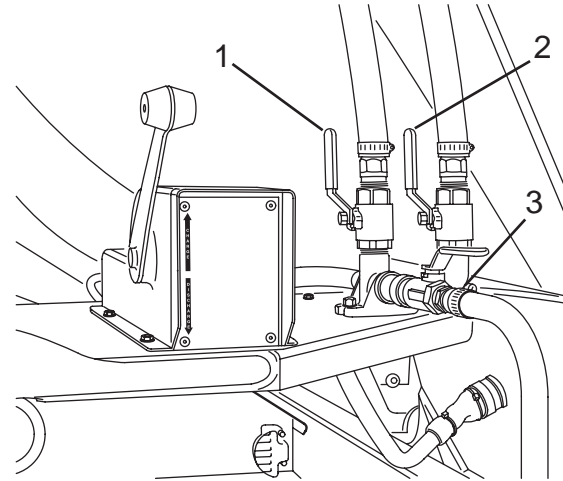

Figure 83

## NOTE

**Inspect hoses for low points that may retain water, even after the system has been drained.**

**If a low spot is noted, have your service department reposition hoses to eliminate the low spot.**

14. Open the drain petcock located at the lowest point in the supply hose (Figure 84, Item 1).

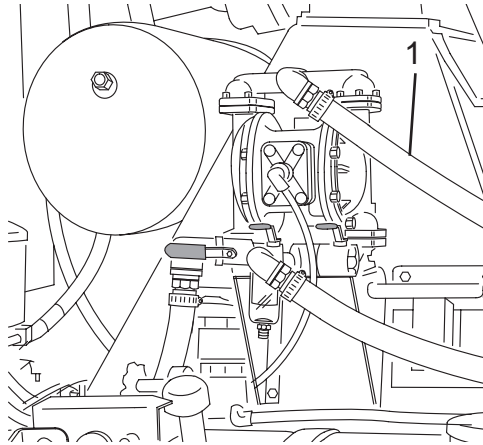

Figure 84

15. Turn the pump off by turning the air pressure control valve to the OFF position.

**NOTE**

**If possible, drain and remove wash-out hose(s), and store hose(s) in the cab.**

16. Open all water control valves and outlets and leave them open until the next use.

## 9.0 Water System Functions

### 9.1 Wash-Out Hoses

The wash-out hose provides a means for cleaning the mixer system after completing a delivery.

The Mixer is equipped with a hose (Figure 85, Item 5) at the rear of the Mixer. The flow to the hose is controlled by a ball valve (Figure 84, Item 1). The Mixer may also be equipped with additional (optional) hoses. **NOTE: The fins, charge hopper, collector, and other components on the rear of the Mixer can be washed from the ground instead of standing on the platform.**

#### 9.1.1 Upper Wash-Out Hose (Optional)

An optional upper water hose (Figure 85, Item 4) is available to make cleaning of the charge hopper and drum easier.

The flow to the hose is controlled by a ball valve (Figure 84, Item 2) located at the rear of the Mixer.

#### 9.1.2 Front Wash-Out Hose (Optional)

An optional front water hose is available to make cleaning of the front of the Mixer easier, or to use as auxiliary water source on the pour site.

The flow to the hose is controlled by a ball valve located at the front of the Mixer.

### 9.1.3 Valve Drain (Optional)

The valves may be equipped with a drain option. This feature automatically drains the water from the hose beyond the valve, through a small hole at the rear of the valves (Figure 85, Item 3).

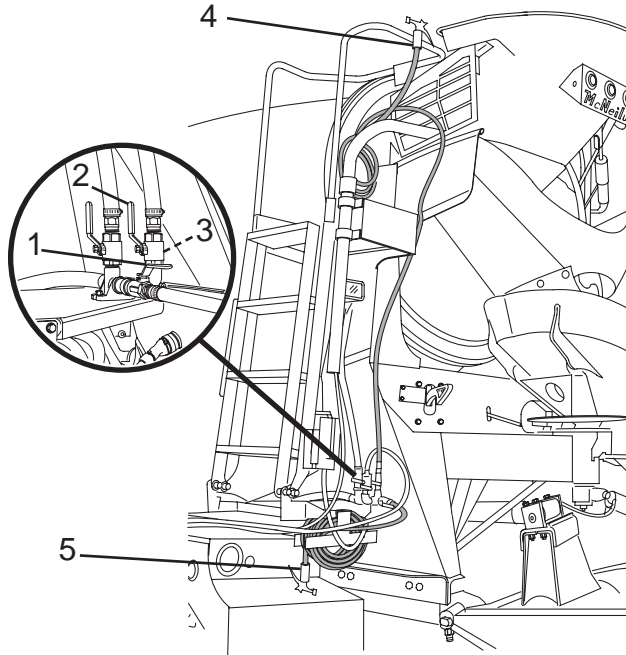

Figure 85

### 9.2 Spray Bar (Optional)

Mixers may be equipped with an optional spray bar (Figure 86, Item 1). The spray bar allows water to be sprayed on the drum to cool the drum. The spray prevents the concrete from setting up prematurely in warm climates.

The flow of water to the spray bar is controlled by a ball valve (Figure 86, Item 2).

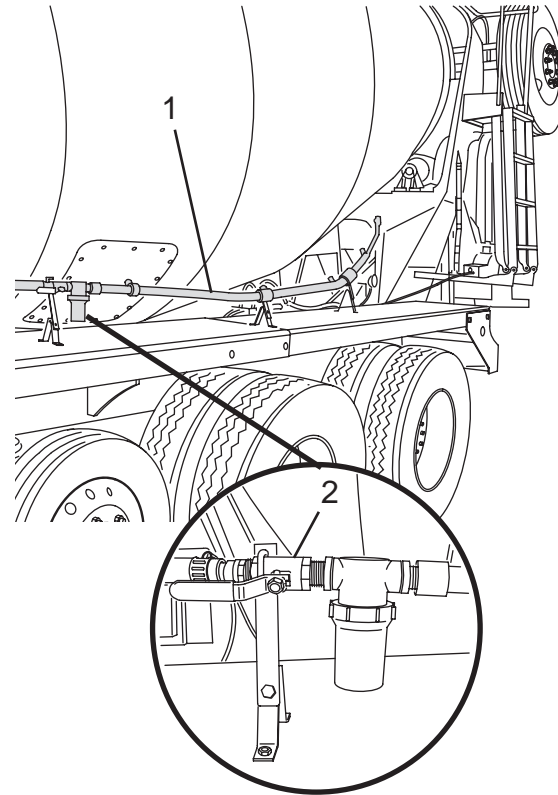

Figure 86

## 9.3 Water Meter Function (Optional)

Mixer may be equipped with an optional water meter to allow monitoring of water used. There are four types of meters available: Precision, BR Industries, GPI®, and Signet.

### 9.3.1 Precision Water Meters

The Precision PMM™ water meter (Figure 87) is installed directly in the water supply line to monitor the amount of water used.

The meter has a build-in register that is protected by a cover. The register records the amount of water used.

The counter records the number of gallons used to 1/10 of a gallon (0.4 liter).

To read the meter:

1. Before discharging water, record the counter reading and the position of the sweep hands on the “10” and “1” (tenths of a gallon) counters:
  - a. Record the reading from the counter (Figure 87, Item 1), in this case 220 gallons (833 liters).
  - b. Add the reading from the sweep hand on the “10” counter (Figure 87, Item 2), in this case 1 gallon (3.8 liter).
  - c. Add the reading from the sweep hand on the “1” (tenths of a gallon) counter (Figure 87, Item 3), in this case 0.1 gallon (0.4 liter). The actual reading of the meter is 221.1 gallons (836 liters).

2. Discharge water as needed until the desired amount of water is determined from the original meter reading.

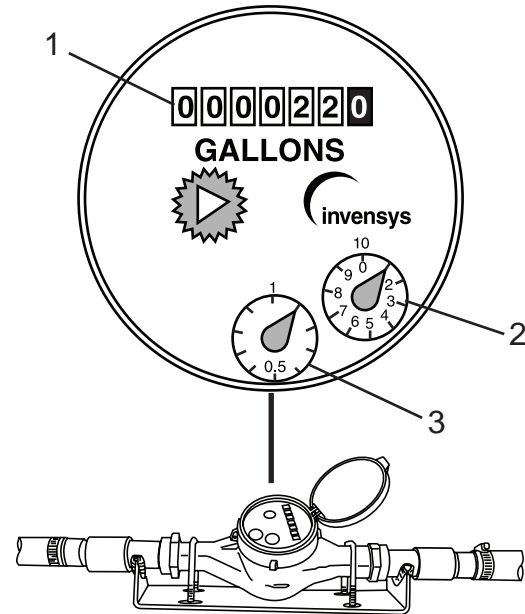

Figure 87

### 9.3.2 BR Industries (BM-25) Water Meter

The BM-25 meter is installed directly in the water supply line to monitor the amount of water used.

#### **CAUTION**

**The BM-25 water meter is designed to be used with water at temperatures up to 131°F (55°C). Exposing the meter to temperatures higher than 131°F (55°C) may result in damage to the meter.**

The meter has a display that is protected by a cover. The meter displays the amount of water used in gallons and liters.

To use the meter:

1. Slide the retaining strap (Figure 88 Item 1) to one side and open the cover (Figure 88, Item 2).

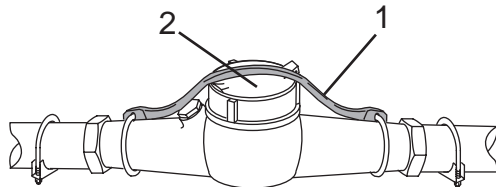

Figure 88

2. Reset the display by turning the collar (Figure 89, Item 1) counterclockwise until the pointer is aligned with "0".

3. Discharge water until the desired amount of water is displayed on the meter.

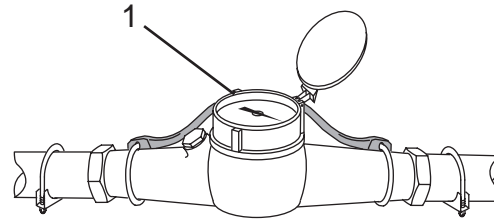

Figure 89

#### **CAUTION**

**Keep the cover closed and secured with a strap when not using the water meter. Failure to comply may cause damage to the equipment.**

4. Close the cover (Figure 88, Item 2) and secure using the retaining strap (Figure 88, Item 1).

**9.3.3 GPI® Water Meters**

The GPI® water meter (Figure 90, Item 1) is installed directly in the “Add Water” line to monitor the amount of water added to the mixer drum.

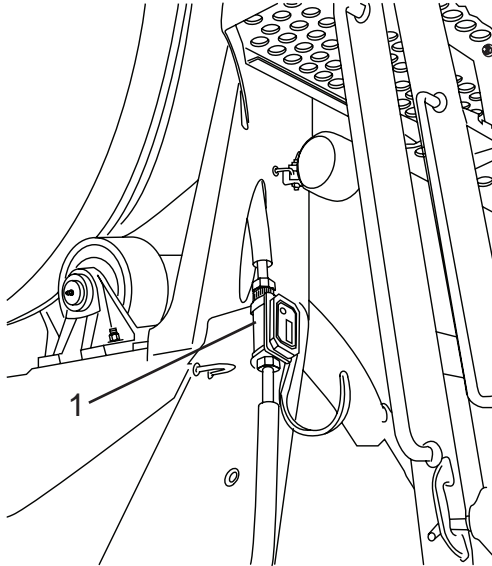

Figure 90

The meter is activated automatically when water flows through the meter. The meter can be manually activated by briefly pressing the DISPLAY button (Figure 91, Item 1).

The meter records two flow totals measured in gallons: “Batch” and “Cumulative.”

The “Batch” total (Figure 91, Item 3) is a record of flow used during a single use. When the meter is in “Batch” mode, “TTL1” (Figure 91, Item 2) will be displayed in the upper left corner of the meter display. This reading can be reset.

The “Cumulative” total is a record of continuous flow usage, from usage to usage. This is displayed as “TTL2” on the meter display. This setting cannot be reset; however, the display will reset to zero after the display reaches “9999.”

The meter is powered by two AAA alkaline batteries. If power is lost, the “Batch” and “Cumulative” totals will reset to zero.

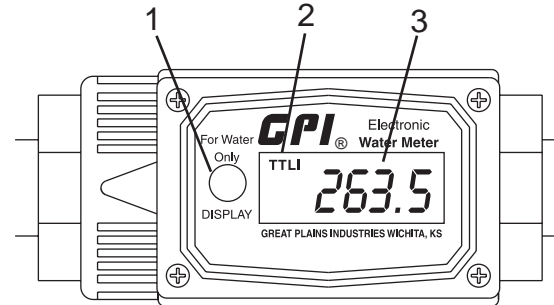

Figure 91

The meter has a power-saving feature, and will automatically shut off after one minute if no usage is detected.

To select display modes:

## NOTE

**On power-up, the meter will display the last total accessed during the previous use.**

1. Activate the display by briefly pressing the DISPLAY button (Figure 92, Item 1).
2. Briefly press the DISPLAY button (Figure 92, Item 1) to change the total displayed - "Batch" mode (displayed as "TTL1") or "Cumulative" mode (displayed as "TTL2") (Figure 92, Item 2).
3. To reset the "Batch" total display, press and hold the DISPLAY button (Figure 92, Item 1) for three seconds.

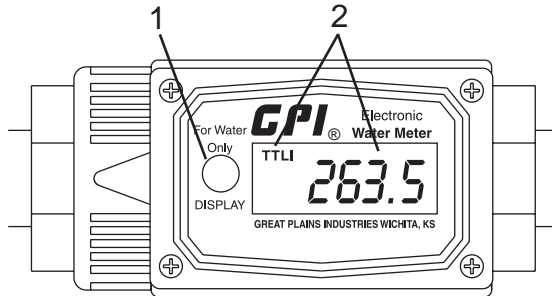

Figure 92

### 9.3.4 UFM Water Meters

For UFM water meters, the information for the amount of water added will be saved in the display mix log, recorded by time and date.

### 9.3.5 Operation

1. Before discharging, press the reset switch (Figure 93, Item 1) to reset the counter display (Figure 93, Item 2).
2. Discharge water as needed until the desired amount of water is displayed.

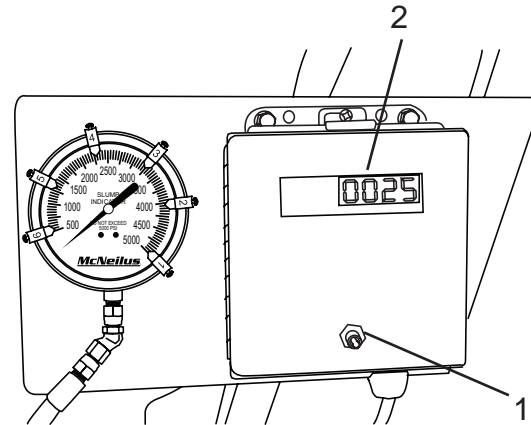

Figure 93

## 10.0 Operating Procedures

### 10.1 Start-Up Procedure

#### NOTE

**Perform pre-trip inspection of chassis and Mixer according to all federal, state, and local laws.**

Before starting the vehicle, make certain that all daily checks have been completed and verified. (See PREVENTIVE MAINTENANCE INTERVALS.)

Perform a walk-around inspection to verify that all controls and components (main and fold-over chutes, chute extensions, hoses, etc.) are properly stored and secured.

### 10.2 Warm-Up Procedure

At start-up of the equipment each morning, it is important to cycle through each of the main hydraulic and air circuits to be certain each circuit is functioning properly. Cycling through each operation also helps ensure that the hydraulic fluid is up to operating temperature and is present throughout the system.

Cycle through each of the following operations:

1. Main Chute Functions – Cycle 3 times
2. Chute Air Lock Function (if equipped) – 1 time
3. Flip-Up Charge Hopper Function (if equipped) – 1 time

#### NOTE

**Allow the hydraulic oil to warm to operating temperature before rotating the drum.**

4. Drum Functions – Rotate in CHARGE and DISCHARGE direction for 5 minutes.

#### CAUTION

**If you detect a problem with any control function, it must be repaired immediately. DO NOT operate the Mixer with malfunctioning controls.**

**Failure to comply may result in damage to the equipment.**

After completing the cycle tests, inspect the Mixer for any hydraulic leaks. If leaks are detected, correct them BEFORE the Mixer is placed into operation.

## 10.3 Drum Operation

### 10.3.1 Drum Control Function

1. Set the engine speed at approximately 1200 rpm. This will ensure adequate torque delivery to the pump and will ensure adequate charge pump fluid delivery to the hydraulic system. This is especially important when handling low slump concrete. Failure to set the proper engine speed may result in erratic drum operation or even cause the drum to stop turning.
2. Control the drum speed by manipulating the drum control lever (Figure 94, Item 1) in the cab, or the control lever (Figure 95, Item 1) on the drum control lever at the rear of the truck.

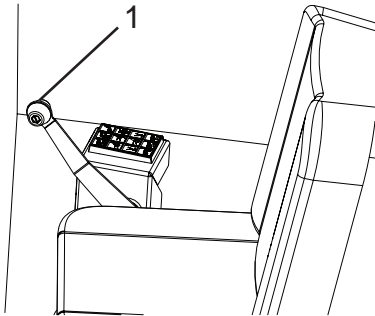

Figure 94

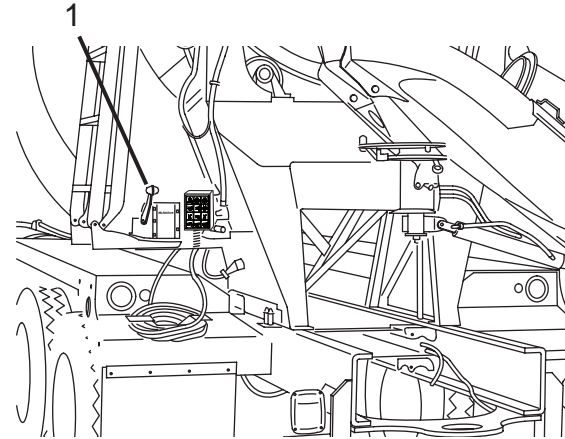
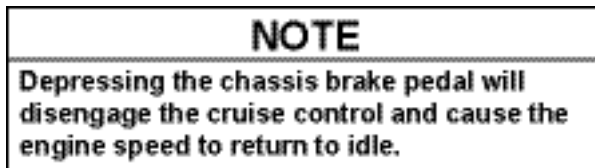

Figure 95

## 10.4 Adjusting the Throttle Speed

When using the rear pendant control keypad to adjust the throttle speed, the procedures will vary, depending on the engine installed in the chassis. Check the chassis information supplied with the Mixer to determine which engine is installed in your truck.



### 10.4.1 Paccar, Navistar, and Detroit Diesel Engines

1. Place the chassis cruise control in the ON position, apply the parking brake, and place the automatic transmission in NEUTRAL. Ensure the Drum STOP is OFF (drum must be turning) and Constant Speed is OFF. (Refer to the chassis information provided with the Mixer for further information.)

Throttle Up: Push and hold the THROTTLE ADVANCE button (on the rear pendant control keypad or in the multiplex controls) until the desired speed is obtained, and release the button/switch. The THROTTLE ADVANCE button can also be pressed and released to advance the throttle speed in increments. The THROTTLE ADVANCE button is designated by the rabbit

symbol on the rear pendant control keypad.

2. Throttle Down: Push and hold the THROTTLE RETARD button (on the rear pendant control keypad), until the desired speed is obtained, and release the button/switch. The THROTTLE RETARD button can also be pressed and released to reduce the throttle speed in increments. The THROTTLE RETARD button is designated by the turtle symbol on the rear pendant control keypad.

### 10.4.2 Mack® Engines – Rear Pendant

#### To use the Rear Throttle Controls or the touch screen:

- Ensure the parking brake is set and the Mixer is in NEUTRAL
  - Drum STOP must be OFF (drum must be turning)
  - Constant Speed must be OFF
  - Rear Pendant enabled (version 1.3.4 or earlier, contact McNeilus Mixer Service for details at 888-686-7278)
  - Icons are on the Rear Pendant or on the touch screen display under the Drum Control selection
1. Press and release the Throttle Raise button (rabbit icon) to achieve maximum PTO speed.
  2. Press and release the Throttle Lower button (turtle icon) to achieve pouring PTO speed (normally 1200 RPM)
  3. To bring remote PTO speed back to idle, press and hold the Throttle Lower button (turtle icon).

### 10.4.3 Cummins® Engines

- **Ensure the parking brake is set and the Mixer is in NEUTRAL**
  - Drum STOP must be OFF (drum must be turning)
  - Constant Speed must be OFF
  - Rear Pendant enabled (version 1.3.4 or earlier, contact McNeilus Mixer Service for details at 888-686-7278)
  - Icons are on the Rear Pendant or on the touch screen display under the Drum Control selection
1. Press and release the Throttle Raise button (rabbit icon) to achieve maximum PTO speed.
  2. Press and release the Throttle Lower button (turtle icon) to achieve pouring PTO speed (normally 1200 RPM)
  3. To bring remote PTO speed back to idle, press and hold the Throttle Lower button (turtle icon).

## 10.5 Loading the Mixer Drum

There are three types of concrete mixes that may be loaded into the Mixer. Each type of concrete has different mixing requirements.

The three mix types are:

**Truck Mixed Concrete:** In truck mixed concrete, all of the ingredients are charged directly into the truck mixer. No plant mixing is involved. Some or all of the mixing water is usually introduced at the plant.

**Shrink Mixed Concrete:** Shrink mixed concrete is partially mixed in a plant mixer and the concrete is then loaded into a truck mixer. Mixing is completed in the truck mixer.

**Central Mixed Concrete:** Central mixed concrete is completely mixed in a plant mixer.

1. If equipped with a flip-up charge hopper, make sure the hopper is lowered.
2. Pull or back the Mixer into the plant's load lane.
3. Position the charge hopper directly under the discharge chute at the batch plant.
4. Set the engine speed to maximum governed rpm.
5. Place the drum control into fast charge. The optimum drum speed for loading will vary.
6. After loading is complete, check the concrete slump and add water as needed.
7. Set the drum control to the CHARGE direction at the lowest drum speed.
8. Fill the water tank(s). In cold weather, the water may be hot, so be extremely careful.
9. Rinse the charge hopper.
10. Pick up delivery ticket, and make sure the ticket matches the materials loaded in your truck.

**NOTE**

The mixer drum should be rotating in the CHARGE direction at all times when the drum is filled with concrete and not discharging.

**NOTE**

Proper mixing speed for the McNeilus drum is 12 to 14 rpm. In general, a proper mix can be obtained with 70 revolutions (at maximum drum speed) of the mixer drum. This count begins when the Mixer is fully loaded and ends when the Mixer begins transport to the job site. During transport, the drum speed should be approximately 1-1/2 rpm.

## 10.6 Traveling to the Job Site

Before beginning travel to the job site, be sure that the Mixer is properly prepared for travel. This means that:

1. Access ladder(s) are folded up and securely latched.
2. Rear control pendant is properly stowed and secured.
3. Chute and chute extensions are clean and free of concrete and debris.

4. Chute extensions are properly stowed and secured.
5. Wash-out hose(s) are properly stowed and secured.
6. Fold-over chute is folded over the main chute and is properly secured.
7. Main chute is positioned with the end of the chute pointing toward the curb, and is locked using the manual chute lock.

** DANGER**

**Water tank(s) must be depressurized prior to transit to or from job site.  
Serious personal injury or death may occur.**

8. Water tank(s) are filled and depressurized and the water system is purged.

** CAUTION**

**Do not stop the drum while in transit.  
Driving the vehicle without the drum rotating may cause damage to the equipment.**

9. Drum is rotating in the CHARGE direction (CW) and is set at the proper speed (approximately 1 to 1-1/2 rpm, slower for longer transport distances, higher for shorter transport distances).

## 10.7 Positioning the Truck for Discharge

Before pulling into the pour site (parking site for the truck when unloading concrete), it will be necessary to inspect the proposed access route to the pour site and the pour location to make sure it is safe to proceed.

If any hazards are noted, an alternate route must be determined or, if possible, the hazards must be removed.

### **WARNING**

**At the job site, use the lowest transmission gear and proceed at low speed, 3 mph (4.8 km/h) maximum, to the discharge area.**

Drive the Mixer slowly to the pour site, staying on the pre-determined route.

### **DANGER**

**Never back up without taking every precaution to be sure the rear is clear. Check behind truck before backing up. Watch mirrors for activity. Never back up the Mixer unless and until you are completely sure it is safe. Use a spotter/observer and/or get out and check yourself to ensure it is safe to do so.**

If it is necessary to back the truck to the pour site, use a spotter to guide you into the site. The spotter should be standing to the side in clear view of your mirrors. The area behind the truck must be free of any other people.

## 10.8 Chute Operation

### 10.8.1 Unfold the Fold-Over Chute

#### **WARNING**

**Do not let persons, other than the driver, handle the chutes, unfold the foldover, and/or remove extension, or stow and secure the extensions for transit. Keep hands away from chute hardware where the chutes connect. Never stand in the path of the chute as it is being unfolded or while in use. Failure to follow the warnings concerning chute safety may result in serious injury.**

#### **WARNING**

**Keep hands and body parts away from the chute pinch points. Failure may result in serious injury.**

**CAUTION**

Do not move the vehicle with the fold-over chute extended and chute extensions installed. Driving the vehicle with chute extensions installed may cause damage to equipment.

**NOTE**

If the Mixer is equipped with an optional hydraulic fold-over chute, see “Hydraulic Fold-Over Chute” for more information.

1. Position the main chute so that there is sufficient room behind the chute. Lock the main chute using the manual chute lock or the optional chute air lock.
2. Disconnect the retaining chain (Figure 96, Item 1) from the fold-over chute (Figure 96, Item 2).
3. Grasp the fold-over chute by the handles (Figure 96, Item 3), and pivot the fold-over chute down until it firmly engages the main chute.

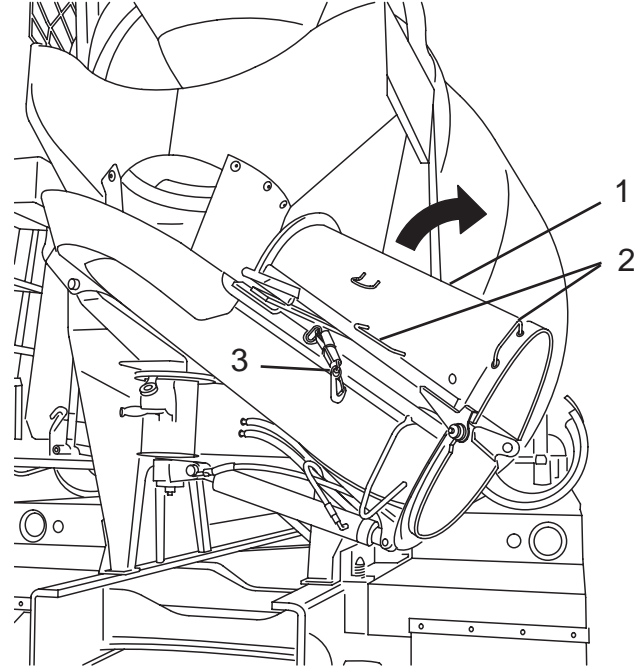

Figure 96

## 10.8.2 Using Chute Extensions

 **DANGER**

Do not over-load chute extensions. Maximum load capacity of 400 lbs. per chute extension.

 **DANGER**

Inspect chute extensions prior to each use. Never use a damaged chute extension or a chute extension that has been driven over. Replace damaged chute extensions immediately.

 **DANGER**

Never stand on a chute or chute extensions. Do not use the chute as a crane to pull or transport objects.

 **CAUTION**

Do not move the vehicle with the fold-over chute extended and chute extensions installed. Driving the vehicle with chute extensions installed may cause damage to equipment.

 **WARNING**

Do not let persons, other than the driver, handle the chutes, unfold the foldover, and/or remove extension, or stow and secure the extensions for transit. Keep hands away from chute hardware where the chutes connect. Never stand in the path of the chute as it is being unfolded or while in use. Failure to follow the warnings concerning chute safety may result in serious injury.

 **CAUTION**

Do not use more chute extensions than are specified for your Mixer. Never exceed three chute extensions.

Do not use any other type or style of chute extensions, other than ones designed for use with your Mixer.

Using additional chute extensions, or the improper type of chute extensions, may result in personal injury or damage to equipment.

1. Lock the main chute lock or optional chute air lock.
2. Unfold the fold-over chute.
3. Remove the number of chute extensions needed for the pour from chute storage.
4. Install the needed number of chute extensions on the fold-over chute. Never exceed three chute extensions.

### 10.8.3 Position the Discharge Chute Assembly

#### CAUTION

**Do not move the vehicle with the fold-over chute extended and chute extensions installed. Driving the vehicle with chute extensions installed may cause damage to equipment.**

1. Grasp the main chute handle and release the main chute lock using the manual chute lock or optional chute air lock.
2. Move the discharge chute to the desired location and lock the main chute with the manual chute lock or optional chute air lock.
3. Raise the main chute as needed using the CHUTE UP/DOWN switch on the rear pendant.

#### WARNING

**When the chute lock is released, the chute may shift unexpectedly, especially if the truck is parked on an incline.**

**Secure the chute before releasing the chute lock.**

**Failure to comply could result in extensive machine damage and serious personal injury.**

4. If it becomes necessary to move the chute while discharging:
  - a. Hold the chute securely.
  - b. Release the main chute lock using the manual chute lock or optional chute air lock.
  - c. Move the chute to the desired location.
  - d. Lock the chute using the manual chute lock or optional chute air lock.
5. If it becomes necessary to move the truck to a new location in order to continue discharging the load:
  - a. Stop discharging.
  - b. Remove the chute extensions.

#### NOTE

**If moving the truck less than 15 feet (4.6 meters), the fold-over chute may be left extended.**

- c. Fold the fold-over chute.

d. Move the truck to the new location and install the chute extensions.

## 10.9 Discharging the Load

1. Park the truck safely. (Refer to the Operator's Manual supplied by the chassis supplier for all parking procedures.) The engine can remain at idle.
2. Unfold the fold-over chute and install chute extensions as needed.
3. Position the discharge chute assembly as needed.
4. If discharging low slump concrete, move the charge hopper away (if equipped with a flip-up or Swing Away Throat charge hopper).
5. To discharge, set the engine speed to 1100 to 1200 rpm, and set the drum control to DISCHARGE direction at the desired speed. A drum speed of 2 rpm will be sufficient for most work; however, greater or lesser speeds can be used, depending on the job conditions and type of concrete mix. A good rule of thumb to follow is, the higher the slump of the concrete, the greater the allowable drum rpm; the lower the slump, the slower the drum should rotate for maximum discharge rate.
6. The main chute position is easily controlled by adjusting the chute height with the chute lifter and rotating the chute manually with the chute lifter and rotating the chute manually about its pivot point. A lock system is provided to lock the chutes and prevent rotation when leaving the purging position.

7. If it is necessary to add water to the concrete mix before discharging the load, activate the water injection system.

## 10.10 Wash Down the Mixer Before Leaving the Job Site

### **WARNING**

**The chassis transmission must be in neutral and the parking brake set before attempting to operate the Mixer with external controls. Failure to follow this procedure could result in extensive machine damage and serious injury to personnel.**

### **NOTE**

**The actual wash-down procedure may vary, depending on your company policies and procedures, and may or may not include all of the following steps.**

### **NOTE**

**Do not discharge leftover concrete on the job site or anywhere else, unless specifically instructed to do so by a company manager. Return leftover concrete to the plant for proper disposal.**

1. Move the Mixer to the designated clean-out area.
2. Park the truck safely. (Refer to the Operator's Manual supplied by the chassis supplier for all parking procedures.)

### NOTE

**Never allow concrete wash water to enter a catch basin, creek, or storm drain, or flow onto the road or gutter.**

**Never flush the drum out on the job site; this should be done only in the proper designated area at the plant yard.**

**Improper discharge of wash water is illegal and can result in fines.**

3. Set the mixer drum to rotate in the CHARGE position at no more than 4 rpm.

### WARNING

**Use caution when working near rotating parts. Loose clothing may become caught.**

**Failure to follow the warnings may result in serious injury.**

### WARNING

**Do not climb on ladders or ride on platforms (if equipped with either) while the truck is in motion or when ladders or platforms are wet and slippery. Serious personal injury may result due to a fall.**

### WARNING

**Use the three-point contact method (either two hands and one foot, or two feet and one hand on the ladder at all times) when climbing the ladder. Always face the ladder when climbing up or down. Serious personal injury may result due to a fall.**

### WARNING

**Do not allow anyone but a trained operator to climb on ladders. Serious personal injury may result due to a fall.**

4. Unfold the access ladder (Figure 97, Item 5).

**NOTE: The fins, charge hopper, collector, and other components on the rear of the Mixer can be washed from the ground instead of standing on the platform.**

5. If equipped, turn the wash-out system ON.
6. Turn on the wash-out hose valve (Figure 97, Item 4).

### **WARNING**

**When using pressurized water, spray water at an angle to prevent splash-back.  
Never aim pressurized water toward another person.  
Failure to follow the warnings may result in serious injury.**

7. Using the wash-out hose (Figure 97, Item 1), start at the top and wash out the charge hopper (Figure 97, Item 2), the interior of the drum, the main chute (Figure 97, Item 3), and chute extensions.

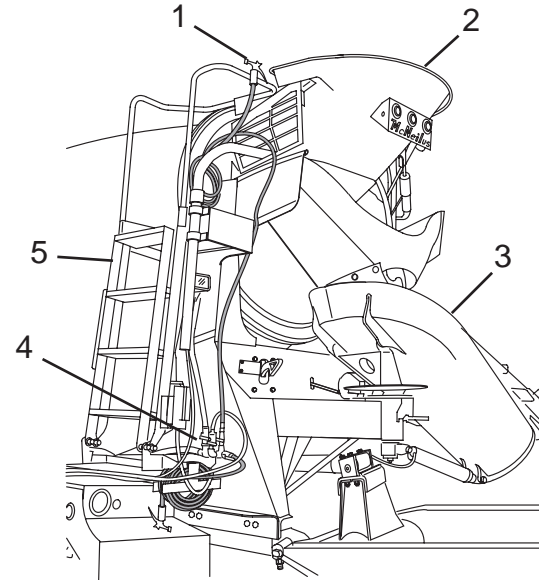

Figure 97

8. Check for concrete build-up; make a note of any concrete that cannot be washed out for future reference. Let the equipment manager know about excessive build-up.
9. Wash any spilled/splashed concrete and/or debris from the exterior of the drum, rear pedestal, fenders, and any surface of the Mixer as needed.

10. Remove and properly stow the chute extensions. Wash off any concrete that may have been missed before storing the chute extensions.
11. Turn off the wash-out hose valve.

** DANGER**

**Water tank(s) must be depressurized prior to transit to or from job site. Serious personal injury or death may occur.**

12. Depressurize the water tank(s) and purge the water system.

** WARNING**

**Never allow the water from the tank to drain onto a public sidewalk or roadway. Water may cause the sidewalk or roadway to become slippery. Always drain the water system at a location designated by the job site manager or in compliance with your company policy.**

**Failure to comply may result in serious personal injury or death.**

** CAUTION**

**Be sure to drain the water system after each use when operating in temperatures below freezing.**

**Failure to drain the system may cause damage to equipment.**

13. If operating in temperatures below freezing, the water tank(s) must be drained. (See Draining the Water System for a pressurized water system or for a pump water system.)
14. Properly stow the wash-out hose(s).
15. Return the fold-over chute to the STORAGE position, and position and lock the main chute in the TRANSPORT position, using the manual chute lock.
16. Fold up the access ladder and make sure it is securely latched.

### 10.11 Returning from the Job Site

Before beginning travel from the job site back to the plant, be sure that the Mixer is properly prepared for travel.

This means that:

- All access ladders are folded up and securely latched
- Rear control pendant is properly stowed and secured
- All spilled concrete is washed off the Mixer

- Mixer and chassis surfaces are free of mud or debris that may be dropped on the road or thrown onto cars while driving
- Chute and chute extensions are clean and free of concrete and debris

### CAUTION

**Chute extensions must be secured on the truck before leaving the job site. Failure to comply may result in damage to the equipment.**

- Chute extensions are properly stowed and secured
- Wash-out hose(s) is properly stowed and secured
- Main chute is positioned with the end of the chute pointing toward the curb, and is locked using the manual chute lock
- Water tank(s) is depressurized
- If operating in temperatures below freezing, the water tank(s) should be drained

### CAUTION

**Always rotate drum when truck is in motion. Never stop the drum while driving. Driving the truck without the drum rotating will damage equipment.**

- Drum is rotating in the CHARGE direction (CW) and is set at the proper speed (approximately 1 to 1-1/2 rpm)

## 10.12 End-of-Day Cleaning Procedure

Keeping the drum clean is important to ensure proper operation and extend drum life. The drum should be cleaned thoroughly at the end of each work day. Use the following procedure that matches the type of drum installed on your Mixer.

### 10.12.1 Standard (Steel) Drum

1. Empty the mixer drum of all remaining contents per company policy.
2. Set drum to rotate at maximum speed in the CHARGE direction and add approximately 150 to 200 gallons (568 to 757 liters) of fresh or recycled water to the drum.
3. Run the drum at mixing speed for approximately two minutes.
4. Move the Mixer to the appropriate sedimentation pit or pond, or to a reclaimers. Change the drum rotation to the DISCHARGE direction and empty the drum contents.
5. If needed, add 30 to 40 gallons (114 to 150 liters) of water to the drum for a final rinse.
6. Wash the exterior of the Mixer.

### **10.12.2 End-of-Day Checks**

At the end of the day, make certain that:

1. The Mixer drum and chutes are thoroughly washed out.
2. The water system is drained. (See Draining the Water System for a pressurized water system or for a pump water system.)
3. Place the drum drive in the neutral position before shutting down.
4. All equipment is properly shut down.
5. The truck is parked on a firm, level surface. (Refer to the Operator's Manual supplied by the chassis supplier for all shut-down and parking procedures.)
6. Report any mechanical/electrical/hydraulic problems to the appropriate people so that repairs can be made.

## NOTES

## 1.0 Preventive Maintenance

The unit must be checked or inspected each day or before each new shift of operation. Report any deficiencies to your Maintenance Department for correction by skilled service personnel.



### CAUTION

**Correct all identified deficiencies BEFORE operating the Mixer. Failure to correct deficiencies may cause damage to equipment.**

### 1.1 DOT Pre-Trip

Perform pre-trip inspection of chassis and Mixer according to all federal, state, and local laws.

## 2.0 Preventive Maintenance Intervals

Performing preventive maintenance on your Mixer will prolong the life of its equipment, help prevent expensive downtime, and minimize the potential for problems arising during use.

The following Preventive Maintenance Chart summarizes the requirements to properly maintain your Mixer.

The chart specifies the recommended interval when each item should be performed.

Intervals are listed in calendar and hours-of-use increments. Maintenance should be performed at the increment that occurs first.

The preventive maintenance intervals listed under the **Service** group heading are the maximum days or hours allowed for each maintenance procedure. Continue to repeat the maintenance procedures at the listed intervals.

The Preventive Maintenance Chart identifies the responsibilities to be performed by both the operator and service personnel.

Some maintenance procedures are listed under both the **Operator** group heading and **Service** group heading.

The Daily Checks under the **Operator** group heading identify procedures that can be performed by either the operator or skilled service personnel.

### NOTE

**If the Mixer is operated more hours per day or double-shifted, the maintenance interval must be adjusted accordingly.**

The Preventive Maintenance Chart identifies the responsibilities to be performed by both the operator and service personnel.

Some maintenance procedures are listed under both the **Operator** group heading and Service group heading.

The Daily Checks under the **Operator** group heading identify procedures that can be performed by either the operator or skilled service personnel.

All intervals listed under the **Service** group heading must be performed by skilled service personnel. Refer to the product Service Manual for description of maintenance procedures.

Maintenance procedures are listed under the system of the Mixer that is affected.

**LEGEND**

- R Replace    P Perform
- I Inspect    L Lubricate
- T Torque    C Clean

		Operator				Service			
		Number of Fittings	Daily Checks	Daily (10 Hours)	Weekly (50 Hours)	After First (100 Hours)	Monthly (200 Hours)	Semi-Annually (1250 Hours)	Annually (2500 Hours)

Lubrication - NLGI Grade 2 General Purpose EP Grease									
Drum Roller Bearings	2	L	L						
Remote Lubrication System	2	L	L						
Drum Roller Track (Brush On)	—	I	I						
PTO Shaft – Slip Joint	1			L					
PTO Shaft – U-Joints	2			L					
Main Chute Pivot	1			L					
Main Chute Pivot - Remove Lubrication System	1			L					
Main Chute Manual Lock Shaft	—			L					
Drum Control Lever	2			L					

**LEGEND**

- R Replace    P Perform
- I Inspect    L Lubricate
- T Torque    C Clean

	Operator				Service			
	Number of Fittings	Daily Checks	Daily (10 Hours)	Weekly (50 Hours)	After First (100 Hours)	Monthly (200 Hours)	Semi-Annually (1250 Hours)	Annually (2500 Hours)

Hydraulic System								
Oil Level – Sight Glass		I/P	I/P					
Hydraulic Oil For Ambient Temps < 80°F (27°C) Use ISO Grade 68 For Ambient Temps > 80°F (27°C) Use ISO Grade 100					R		R	
Suction Filter (Rating B10 = 2) [50% efficient at 10 microns] Hydraulic oil at operating temperature: 2 to 5 in-hg, never read more than 10 in-hg					R		R	
Suction Filter – Gate Valve Valve Open (A cable tie must be installed on the valve handle to prevent inadvertent closing of the valve)		I/P	I/P					
Hydraulic System and Components		I			I			
Hydraulic Hoses		I						
Hydraulic Pipes/Tubes		I						

**LEGEND**

- R Replace    P Perform
- I Inspect    L Lubricate
- T Torque    C Clean

Operator	Service						
Number of Fittings	Daily Checks	Daily (10 Hours)	Weekly (50 Hours)	After First (100 Hours)	Monthly (200 Hours)	Semi-Annually (1250 Hours)	Annually (2500 Hours)

ZF Gearbox							
Oil Level – Sight Glass		I/P	I/P				
Lubricant GL5 Spec. 85W-140 Gear Oil Capacity 4.2 gallons, 17 quarts (16.1 liters) Remove dipstick from oil fill port <div style="background-color: #ff8c00; padding: 2px; display: inline-block;"><b>⚠ WARNING</b></div> Pressurized oil may blow out of port when opened. Keep face and body away from port. Serious injury or death may occur.					R		R
CML 12 Gearbox							
Oil Level – Sight Glass*		I/P	I/P				
Lubricant GL5 Spec. 85W-140 Gear Oil Capacity 4.2 gallons, 17 quarts (16.1 liters) Remove dipstick from oil fill port <div style="background-color: #ff8c00; padding: 2px; display: inline-block;"><b>⚠ WARNING</b></div> Pressurized oil may blow out of port when opened. Keep face and body away from port. Serious injury or death may occur.						I*	

\* The lubrication level of the CML 12 gearbox should be checked monthly, but an oil change is not required throughout the normal service life. However, it is recommended to change the oil after 10,000 hours or 6 years.

**LEGEND**

- R Replace    P Perform
- I Inspect    L Lubricate
- T Torque     C Clean

	Operator				Service			
	Number of Fittings	Daily Checks	Daily (10 Hours)	Weekly (50 Hours)	After First (100 Hours)	Monthly (200 Hours)	Semi-Annually (1250 Hours)	Annually (2500 Hours)

**Pneumatic System**

Coalescing Filter		P	P			I/R		
Air Hoses and Fittings		I			I			

**Electrical System**

Lighting System		I			I			
Wire Harness		I			I			

**Standard (Steel) Drum**

Drum Inspection						I		
-----------------	--	--	--	--	--	---	--	--

**Mechanical**

Mixer Body and Components		I			I			
Water Tank		I						
Access Ladder(s) and Mounting Hardware		I						
Wheel Lug Nuts Tighten all lug nuts (including pusher axle) to 450 lb-ft (610 N•m)				T				
Chute Extensions		I						

**LEGEND**

- R Replace    P Perform
- I Inspect    L Lubricate
- T Torque    C Clean

		Operator				Service			
		Number of Fittings	Daily Checks	Daily (10 Hours)	Weekly (50 Hours)	After First (100 Hours)	Monthly (200 Hours)	Semi-Annually (1250 Hours)	Annually (2500 Hours)

Optional Equipment									
Spray Bar Strainer (50 Mesh Strainer)					C/I <sup>1</sup>				
Chute Assist		I	I						
Operation									
Mixer Controls		P				P			
Safety Decals		I							

<sup>1</sup> Replace strainer as required.

## 3.0 Daily Checks

### 3.1 Safety Decals

- **Daily Checks** – A complete walk around of the vehicle to inspect the safety decals should be performed every day before operation. If any of the safety decals are damaged, illegible, or missing, they must be replaced before operation.

For the proper location and part numbers of the safety decals for the Mixer, see SAFETY DECALS AND PLACARDS. If you are unable to determine the proper safety decal or its placement on the Mixer, call McNeilus Truck and Manufacturing, Inc. at 888-686-7278 for assistance. If any safety decals on the equipment are not clearly readable, contact McNeilus parts and service at 888-686-7278 or [www.streetsmartparts.com](http://www.streetsmartparts.com) for replacements free of charge. Use only McNeilus replacement decals.

For information on any of the chassis safety decals, please contact the chassis manufacturer.

## 3.2 Hydraulic System

### SAFETY NOTICE

**Before entering the Mixer drum, read and follow OSHA Regulations concerning entry and working in “CONFINED SPACE” OSHA 1910.146 and “LOCKOUT/TAGOUT” OSHA 1910.147.**

**Follow OSHA Regulations while performing any work to the Mixer.**

**Follow all safety instructions in your McNeilus Mixer Manual.**

**Shut off truck engine, lock cab doors, and keep keys in your pocket before entering drum, or performing any work to the Mixer.**

**Place magnetic “DANGER” signs on both cab doors. Failure to do so can result in serious personal injury or death.**

**If you have any questions regarding this notice or require further assistance, call McNeilus Truck and Manufacturing, Inc. at 888-686-7278.**

### 3.2.1 Hydraulic Oil Level

- **Daily Checks** – The oil level is checked by the operator or skilled service personnel.

#### NOTE

**Check hydraulic oil level during start-up when the oil temperature is still cold.**

Check the hydraulic oil level with all hydraulic components off and all hydraulic cylinders retracted.

#### NOTE

**The shape and location of the hydraulic reservoir may vary. Round tank configuration shown. Square reservoirs may be mounted on the frame rails, in front of the radiator.**

Check the hydraulic oil level at the sight gauge on the front of the reservoir. Hydraulic oil should be visible at the bottom of the sight gauge (Figure 98, Item 1).

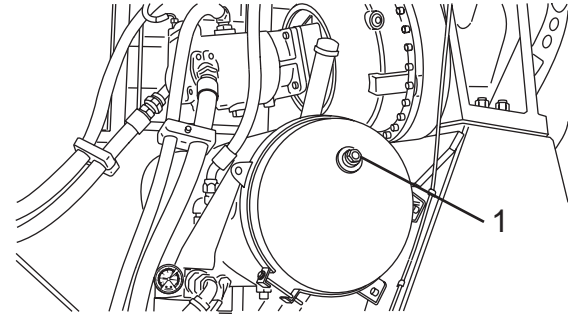

Figure 98

### 3.2.2 Hydraulic System and Components

- **Daily Checks** – The hydraulic system and components are inspected by the operator or skilled service personnel.

Inspect the hydraulic system and components for leaks and damage. Inspect around all fittings and connections. Look for any fresh puddles or drips under the Mixer.

Ensure that all components are securely mounted and that all bolts and nuts are in place and secure.

Inspect for cracks or other damage to the mounting brackets.

### 3.2.3 Hydraulic Hoses and Pipes

- **Daily Checks** – The hydraulic hoses and pipes are inspected by the operator or skilled service personnel.

#### **WARNING**

Any hydraulic tubing which is replaced must conform to SAE J1065 specifications. If incorrect hydraulic tubing is installed, the hydraulic system may fail, causing serious injury. Damaged or leaking tubing must be replaced before the Mixer is returned to service. For best results, always use genuine McNeilus replacement parts.

#### **WARNING**

Correct hoses, fittings, and adapters with the correct SAE rating must be used when replacing hoses to prevent possible serious injury. Always replace hoses, fittings, and adapters with replacements that have a proper, suitable working pressure rating. Replacement hoses must be of correct length and must comply with the hose manufacturer's installation guidelines and recommendations. Hydraulic hoses have the SAE ratings marked on the hose to assist you in selecting the correct hose. Any replacement hydraulic hoses and fittings assemblies must be supplied by the same manufacturer. As an example: Brand "A" hose and brand "B" fitting will not normally be compatible. No "twist" is allowed in the hydraulic hoses. "Twist" may result in premature hose failure.

Inspect hydraulic hoses and pipes for damage and proper clearance with other components. If you find hoses with any such adverse conditions or damage, they must be replaced before the vehicle is returned to service.

The following are examples of hydraulic hose damage to inspect for:

- Bulging (Figure 99, Item 1)
- Cracks (Figure 99, Item 2)
- Cuts (Figure 99, Item 3)
- Abrasion (Figure 99, Item 4)
- Twisting (Figure 99, Item 5)
- Crimped (Figure 99, Item 6)

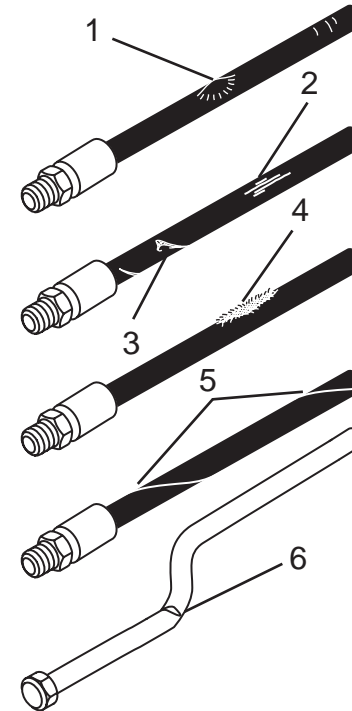

Figure 99

### 3.3 Electrical System

#### SAFETY NOTICE

Before entering the Mixer drum, read and follow OSHA Regulations concerning entry and working in “CONFINED SPACE” OSHA 1910.146 and “LOCKOUT/TAGOUT” OSHA 1910.147.

The following procedures pertain to the use of McNeilus Lockout Procedure Kit.

Shut off truck engine, lock cab doors, and keep keys in your pocket before entering drum, or performing any work to the Mixer.

Place magnetic “DANGER” signs on both cab doors. Failure to do so can result in serious personal injury or death.

Place roller stop assembly base on rear pedestal.

#### SAFETY NOTICE

**CONTINUED:** Make sure roller stop base has a flat, clean surface. Extend turnbuckles so wedges are firmly in place between drum roller track and rollers. Evenly snug up turnbuckles one turn or more if necessary to prevent possible drum rotation. Tighten the turnbuckle jam nuts to secure the wedges in place.

When finished, remove roller stop assembly **FIRST**, then unlock control valve arm and remove “DANGER” signs from doors.

Serious personal injury or death can occur if these procedures are not followed.

If you have any questions regarding this notice or require further assistance, call McNeilus Truck and Manufacturing, Inc. at 888-686-7278.

#### 3.3.1 Lighting System

- **Daily Checks** – The lighting system is inspected by the operator or skilled service personnel.

Check to ensure that all exterior lights on the Mixer and chassis are functioning correctly. Replace any burned-out bulbs with the same type.

### 3.3.2 Wire Harnesses

- **Daily Checks** – The wire harnesses are inspected by the operator or skilled service personnel.

Inspect the wiring harnesses for damage and proper clearance with other components.

The following are examples of wire harness damage to inspect for:

- Cracks (Figure 100, Item 1)
- Cuts (Figure 100, Item 2)
- Abrasion (Figure 100, Item 3)
- Twisting (Figure 100, Item 4)

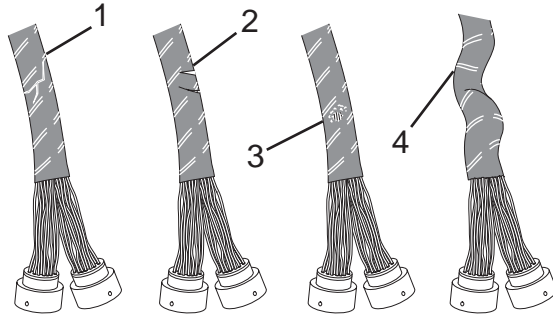

Figure 100

### 3.4 Pneumatic System

#### 3.4.1 Pneumatic Lines and Fittings

- **Daily Checks** – The pneumatic lines and fittings are inspected by the operator or skilled service personnel.

Check the pneumatic lines and fittings for leaks, wear, abrasion, damage, and proper clearance. Ensure that all fittings are secure.

#### 3.4.2 Coalescing Filter

- **Daily Checks** – The coalescing filter is drained by the operator or skilled service personnel.
1. Locate the drain fitting (Figure 101, Item 1) on the bottom of the coalescing filter.
  2. Drain the filter by turning the drain fitting counterclockwise.
  3. After all moisture and contaminants have drained from the canister, turn the drain fitting clockwise.

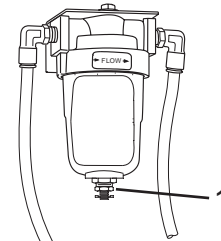

Figure 101

- **Monthly or Every 200 Hours** – The coalescing filter element should be replaced by skilled service personnel.
  1. Drain pneumatic system before removing filter element.
  2. Remove (unscrew) the bowl assembly (Figure 102, Item 1) and O-ring (Figure 102, Item 2).
  3. Remove the retainer (Figure 102, Item 3) and filter element (Figure 102, Item 4) from the head (Figure 102, Item 5).
  4. Install a new filter element (Figure 102, Item 4) and retainer (Figure 102, Item 3).

### CAUTION

**Do not use aromatic solvents to clean the bowl assembly. Clean the bowl assembly using warm, soapy water only. The use of aromatic solvents will result in damage to the bowl assembly.**

5. Clean the bowl assembly (Figure 102, Item 1) using warm, soapy water.
6. Inspect the O-ring (Figure 102, Item 2). Replace if damaged.
7. Install the O-ring (Figure 102, Item 2) and bowl assembly (Figure 102, Item 1) on the filter head (Figure 102, Item 5).

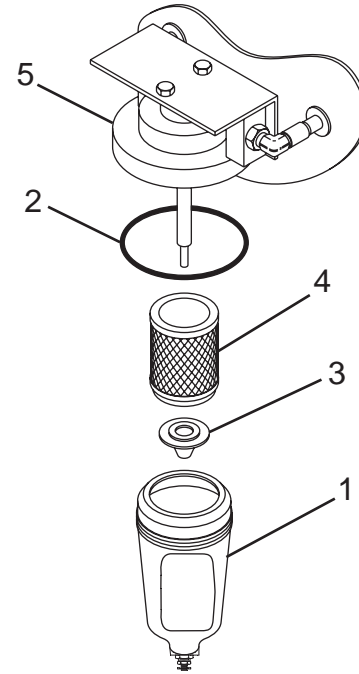

Figure 102

### 3.5 Mechanical System

#### SAFETY NOTICE

Before entering the Mixer drum, read and follow OSHA Regulations concerning entry and working in “CONFINED SPACE” OSHA 1910.146 and “LOCKOUT/TAGOUT” OSHA 1910.147.

Follow OSHA Regulations while performing any work to the Mixer.

Follow all safety instructions in your McNeilus Mixer Manual.

Shut off truck engine, lock cab doors, and keep keys in your pocket before entering drum, or performing any work to the Mixer.

Place magnetic “DANGER” signs on both cab doors. Failure to do so can result in serious personal injury or death.

If you have any questions regarding this notice or require further assistance, call McNeilus Truck and Manufacturing, Inc. at 888-686-7278.

Inspect the pedestals and all components for binding, damage, and loose or missing parts.

Inspect access ladder(s) (Figure 103, Item 1) and mounting hardware for damage and/or loose or missing hardware.

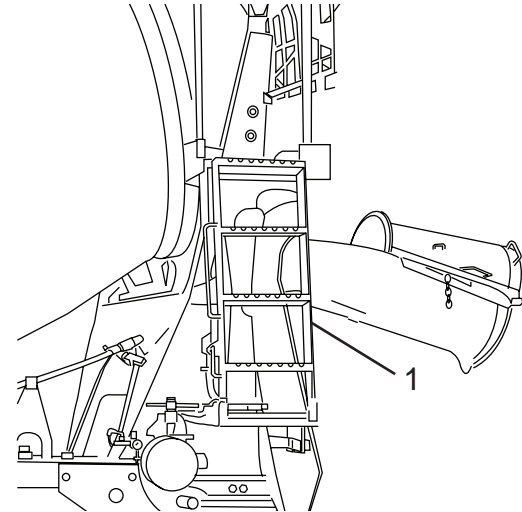

Figure 103

#### 3.5.1 Mixer Components and Pedestals

- **Daily Checks** – The Mixer components should be inspected by the operator or skilled service personnel.

### 3.5.2 Water Tanks

- **Daily Checks** – The water tank(s) and components should be inspected by the operator or skilled service personnel.

#### **CAUTION**

**Do not weld on or near the water tank. If the water tank requires structural repair, contact McNeilus Truck and Manufacturing, Inc. at 888-686-7278.**

**Attempting to repair the water tank will void your warranty. Failure to comply may result in damage to equipment.**

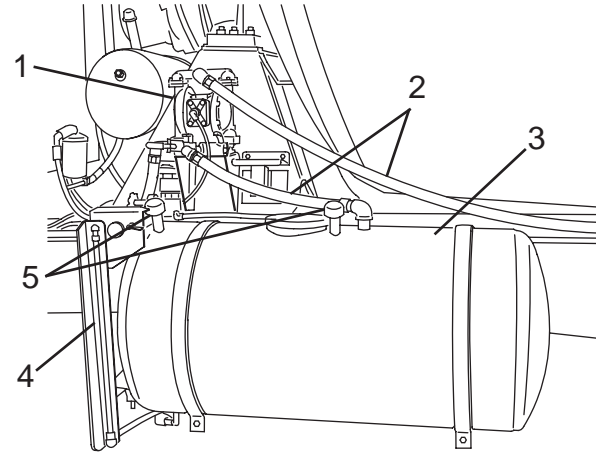

Figure 104

1. Inspect the water tank(s) (Figure 104, Item 3) for leaks, cracks, breaks, or structural damage.
2. Inspect hoses (Figure 104, Item 2) for leaks, cracks, or damage.
3. Inspect sight glass(es) (Figure 104, Item 4) for cracks or damage.
4. Check pump (Figure 104, Item 1) (if equipped) for proper operation.
5. Check breathers (Figure 104, Item 5) (if equipped) to make sure they are free of debris.

6. Check flopper valve (Figure 105, Item 1) for free movement, and make sure it seats properly.
7. Check valves (Figure 105, Items 2 and 3) to make sure they move freely.

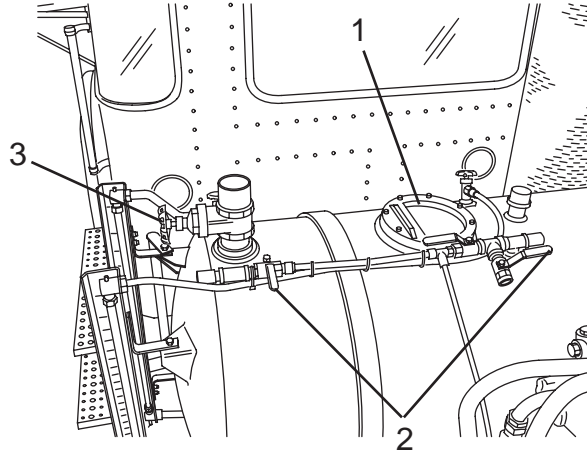

Figure 105

### 3.5.3 Wheel Lug Nut Torque

- **Weekly Checks** – Tighten the tag and pusher wheel lug nuts to 450 ob-ft (610 N•m) using an alternating (star) pattern shown (Figure 106).

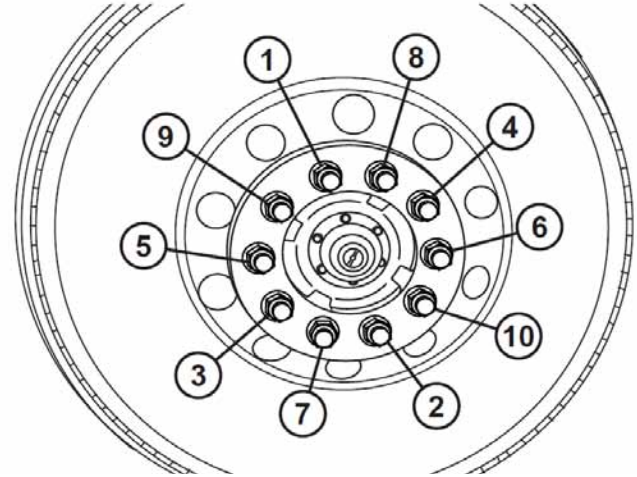

Figure 106

### 3.5.4 Chute Extensions

- **Daily Checks** – The chutes extensions should be inspected by the operator or skilled service personnel.

#### DANGER

**Do not repair metal or composite chute extensions. Serious personal injury or death could occur.**

#### DANGER

**Composite chute extensions are flammable. Do not expose to an open flame or a temperature exceeding 220°F (104°C). Burning chute extensions produce toxic smoke/fumes during combustion. Serious personal injury or death could occur.**

#### CAUTION

**Never clean chute extensions by striking or chiseling. Failure to comply may result in damage to the equipment.**

1. Inspect the chute extensions for cracks, breaks, or structural damage. Replace chute(s) if any damage is noted.

### 3.5.5 Chute Assist

- **Daily Checks** – The chute assist should be inspected daily by the operator or skilled service personnel for wear, cable damage, pulley damage, and the correct tension.

#### WARNING

**The chute assist has pinch points between the main chute and the fold-over chute. Keep hands away from chute hardware where chutes connect. Keep hands away from the pulley system. Failure to comply may result in serious personal injury or death or damage to equipment.**

#### WARNING

**Do not stand under the chute while adjusting or testing the tension of the chute assist. Failure to comply may result in serious personal injury or death.**

To adjust the tension of the chute assist:

1. Park the truck safely. (Refer to the Operator's Manual supplied by the chassis supplier for all shut-down and parking procedures.)
2. Apply the Lockout/Tagout procedure. (See Applying the Lockout/Tagout Procedure.)

3. Put the fold-over chute in the down/open position.
4. Loosen the nuts on the tension rod during the adjustment (Figure 107).
5. Use a pair of vice grips or other suitable tool to hold the tension tube and turn the tension rod clockwise to increase the tension or counter-clockwise to reduce the tension (Figure 107).

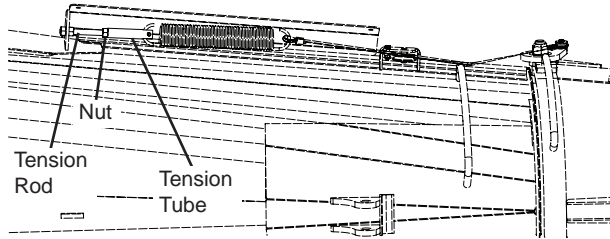

Figure 107

6. Divide the tension adjustment between both sides of the chute assist, making the right side and left side equal.
7. Adjust the tension so when the fold-over chute is in the UP/CLOSED position, the cable is taut and does not droop or sag.
8. Once the proper tension is achieved, apply Blue Loctite® and tighten the nuts to lock the adjustment.
9. Over extension of the spring beyond 22-1/4" will damage the spring.

10. Inspect the chutes and chute assist daily for wear, cable damage, pulley damage, and the correct tension. Inspect and adjust as necessary, especially after the cables and springs stretch.

### 3.6 Standard (Steel) Drum

## SAFETY NOTICE

**Before entering the Mixer drum, read and follow OSHA Regulations concerning entry and working in "CONFINED SPACE" OSHA 1910.146 and "LOCKOUT/TAGOUT" OSHA 1910.147.**

**Follow OSHA Regulations while performing any work to the Mixer.**

**Follow all safety instructions in your McNeilus Mixer Manual.**

**Shut off truck engine, lock cab doors, and keep keys in your pocket before entering drum, or performing any work to the Mixer.**

**Place magnetic "DANGER" signs on both cab doors. Failure to do so can result in serious personal injury or death.**

**If you have any questions regarding this notice or require further assistance, call McNeilus Truck and Manufacturing, Inc. at 888-686-7278.**

### 3.6.1 Standard (Steel) Drum Inspection

- **Daily Checks** – The mixer drum should be inspected by the operator or skilled service personnel.
1. Park the truck safely. (Refer to the Operator's Manual supplied by the chassis supplier for all shut-down and parking procedures.)
  2. Apply the Lockout/Tagout procedure. (See Applying the Lockout/Tagout Procedure.)
  3. Raise the charge hopper.
  4. Inspect the interior of the drum for concrete build-up. Remove concrete as needed. (See Concrete Removal for removal information.)
  5. Check the discharge hopper-to-drip ring clearance (Figure 108, Item 1). Clearance should be 2 inches (51 mm) between the discharge hopper face and the drip ring, and no more than 1 inch (25 mm) radially around the drip ring.
  6. Check the areas where the discharge hopper and drip ring meet for concrete build-up. Remove concrete as needed.

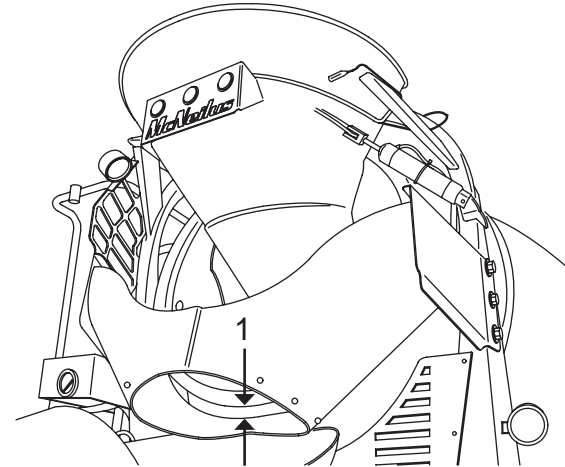

Figure 108

#### **WARNING**

**Crush Hazard—Moving drum can crush you against debouncer. Keep yourself and tools clear of debouncer when drum turns. Drum can snag you before you can react. Failure to follow the warnings may result in serious injury or death.**

7. Check the debouncer-to-drip ring clearance (Figure 109, Item 1), the clearance should be 3/8 to 1/2 inch (10 to 13 mm) at the closest point.

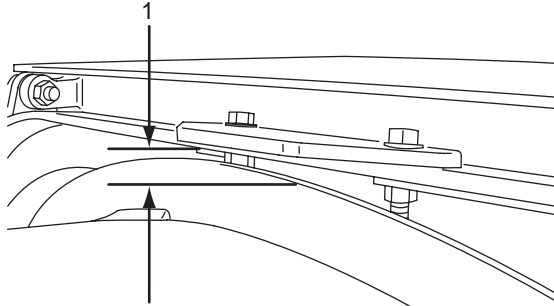

Figure 109

8. Check the drum flange bolt (Figure 110, Item 1) torque. (Refer to the Service Manual for torque valves.) If a bolt turns during this check, that bolt must be removed and replaced with a new Grade 8 bolt.

**NOTE**

**Grade 9 bolts can be purchased with or without a pre-applied threadlocker such as Loctite®. There are different torque valves for bolts with and without a pre-applied threadlocker. Use the procedure that applies to your application.**

New Grade 8 Bolt(s) **without** Pre-Applied Threadlocker:

- a. Clean the threads in the drum.
- b. Apply Loctite® red to the threads of new Grade 9 bolts.
- c. Install and tighten the bolt(s) to the specified torque. (Refer to the Service Manual for torque valve.)

New Grade 8 Bolt(s) **with** Pre-Applied Threadlocker:

- a. Clean the threads in the drum.
- b. Install and tighten new Grade 8 bolt(s) to the specified torque. (Refer to the Service Manual for torque valve.)

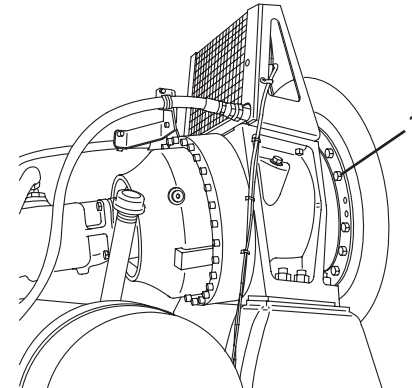

Figure 110

9. Lower charge hopper.
10. Remove the Lockout/Tagout procedure. (See Removing the Lockout/Tagout Procedure.)

### 3.6.2 Concrete Removal

Concrete removal is a permit-required confined space (permit space) situation. Refer to Permit-Required Confined Space (permit space) information in Safety Section 1.0.

1. Park the truck safely. (Refer to the Operator's Manual supplied by the chassis supplier for all shut-down and parking procedures.)
2. Apply the Lockout/Tagout procedure. (See Applying the Lockout/Tagout Procedure.)
3. If the drum hatch is the oval hatch, remove the 12 drum hatch bolts (Figure 111, Item 1), and remove the drum hatch (Figure 111, Item 2).
  - If the drum hatch is the square style, remove the 16 hatch bolts, and remove the drum hatch.
4. Remove the gasket from the drum hatch.
  - If the drum hatch is the square style, remove and inspect the gasket; replace as needed.

#### CAUTION

**Do not use any sharp-edged tools to remove built-up concrete. If a small air/electric power chisel is used, only blunt-tipped chisel inserts may be used.**

5. Remove built-up concrete using a hand maul. Do not use any sharp-edged tools.

If it becomes necessary to chip-out the drum, use a small air/electric power chisel, using only blunt-tipped chisel inserts.

#### CAUTION

**Remove concrete pieces from the drum by hand. Do not discharge concrete pieces by rotating the drum as they may become lodged between the collector and drum, resulting in severe damage.**

6. Remove concrete pieces from the drum by hand.
7. For the oval hatch only: Use silicon around the hatch frame to prevent leaks and install a new gasket on the hatch.
8. For the oval hatch only: Install the drum hatch (Figure 111, Item 1). Loosely install 12 drum hatch bolts (Figure 111, Item 2).
  - For the square hatch only: Install the drum hatch. Loosely install 16 drum hatch bolts.
9. For the oval hatch only: Tighten the drum hatch bolts to 80 lb-ft using an alternating (star) pattern.
  - For the square hatch only: Tighten the drum hatch bolts to 17 lb-ft using an alternating (star) pattern.

10. Remove the Lockout/Tagout procedure. (See Removing the Lockout/Tagout Procedure.)

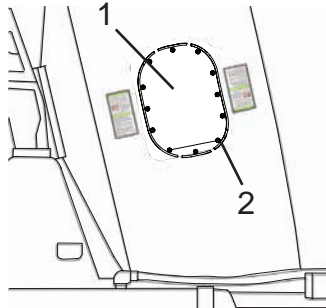

Figure 111

## 3.7 Operation

**⚠ DANGER**

**Be sure people are at least 20 feet (6 meters) away from all areas of the Mixer. Serious personal injury or death may occur.**

### 3.7.1 Mixer Controls

- **Daily Checks** – The mixer controls are checked for proper operation by the operator or skilled service personnel.

Operate all functions to validate that they are operational. Verify that all indicator lights and alarms are operational.

## 4.0 Hydraulic System

### 4.1 Hydraulic Oil Requirements

The lubrication requirements for your McNeilus Mixer are common for hydraulic oils. Hydraulic oils differ from other oils. Hydraulic oils have additives to inhibit water, rust, oxidation, and foaming.

The following table lists the hydraulic oil specifications.

Hydraulic Oil Recommendation		
ISO Grade	68	100
Ambient Temperature	up to 80°F (27°C)	80°F (27°C) and above
Viscosity @ 210°F (99°C)	60 SUS or higher	70 SUS or higher
Viscosity Index	95 to 100	
Pour Point	-20°F to -30°F (-29°C to -34°C)	

### CAUTION

**UTF (Universal Tractor Fluid), TDF (Transmission/Differential Fluid), or ATF (Automatic Transmission Fluid) must not be used in the mixer hydraulic system.**

**Using these hydraulic fluids will cause premature hydrostatic/hydraulic failure, and will void the hydrostatic/hydraulic warranty.**

Change your hydraulic oil and filters every 6 months or 1250 hours (whichever comes first).

### 4.2 Hydraulic Oil Reservoir

Hydraulic oil reservoir may come in one of two types: 21 gallon steel and 22 gallon composite. Depending on the mixer configuration, the reservoir may be mounted in various locations, but is usually mounted to the chassis frame, just ahead of the drum.

### NOTE

**Hydraulic oil must be changed after the first 100 hours.**

The drain plug (Figure 112, Item 2) is a magnetic plug located at the bottom of the reservoir.

The level sight gauge (Figure 112, Item 1) is located on the front of the reservoir.

**CAUTION**

Anytime the shut-off valve is closed and reopened, the nylon strap must be replaced.

Failure to secure the shut-off valve in the open position may cause damage to the hydraulic system.

Make sure the shut-off valve (Figure 112, Item 4) is fully open and not partially closed. A nylon strap (Figure 112, Item 5) must be installed on the shut-off valve to prevent vibration from closing the shut-off valve or inadvertent closing of the valve.

A 10-micron suction hydraulic filter (Figure 112, Item 3) is located between the shut-off valve and hydraulic pump.

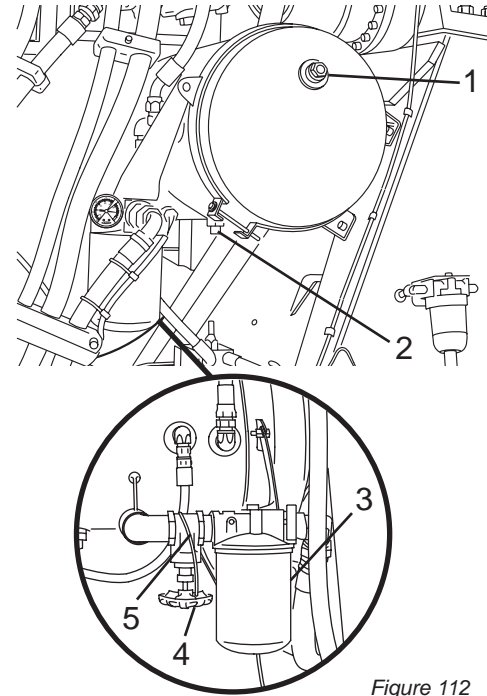

Figure 112

### 4.2.1 Hydraulic Oil Level

With all hydraulic functions in their HOME positions, and all hydraulic cylinders retracted, oil should be visible in the bottom of the sight gauge (Figure 113, Item 2).

### 4.3 Adding Hydraulic Oil

To add hydraulic oil, all cylinders must be fully retracted, remove the filler cap (Figure 113, Item 1) and add oil as necessary.

#### NOTE

When adding hydraulic oil, take every precaution to prevent contaminants from entering the hydraulic system. Cleanliness is extremely important when working with hydraulics.

#### NOTE

If it is necessary to add hydraulic oil often or in large quantities, inspect the hydraulic system for leaks and repair before operating the Mixer.

#### NOTE

Read vacuum gauge when hydraulic oil is at operating temperature.

The suction filter is equipped with a vacuum gauge (Figure 113, Item 3). The gauge indicates the condition of the hydraulic oil filter. Green on the gauge indicates the filter is in good operating condition, yellow indicates the filter will require replacement soon, red indicates the filter is in by-pass mode and must be replaced immediately.

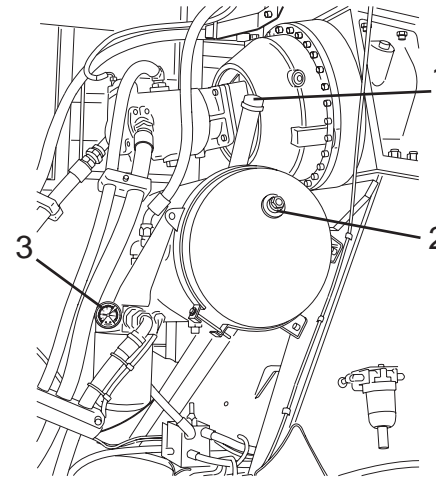

Figure 113

## 5.0 Optional Equipment

### 5.1 Spray Bar Strainer

#### NOTE

Contaminants may vary, depending on the application.

The spray bar strainer (50 mesh) should be cleaned and inspected once a week.

1. Remove (unscrew) the cup (Figure 114, Item 3), and remove the cup and strainer (Figure 114, Item 4) from the strainer head (Figure 114, Item 1).
2. Clean the strainer (Figure 114, Item 4) with clear water. Inspect the strainer. Replace if torn or damaged.
3. Inspect the cup seal (Figure 114, Item 2). Replace if torn or damaged.
4. Install the strainer (Figure 114, Item 4) and cup (Figure 114, Item 3).

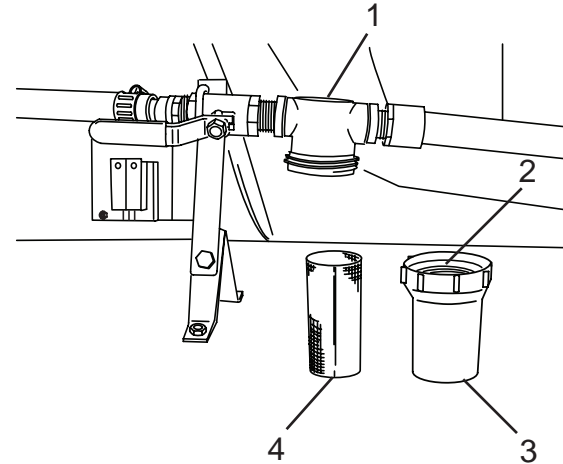

Figure 114

## 5.2 GPI® Water Meters

### 5.2.1 Battery Replacement

1. Remove four screws (Figure 115, Item 2) from the face of the meter and remove the faceplate (Figure 115, Item 1) from the meter body.

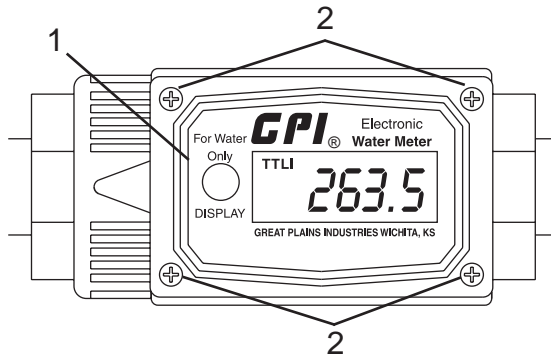

Figure 115

2. Remove the batteries, noting their orientation in the holder.
3. Inspect the terminals for corrosion. Clean as needed.
4. Install new batteries in the same orientation as noted during removal.
5. Inspect the O-ring to make sure it is fully seated in the housing.

6. Activate the display by briefly pressing the DISPLAY button (Figure 116, Item 4).
7. Check the display (Figure 116, Item 3) to verify that it is operating normally. Re-seat the batteries if needed.
8. Install the meter faceplate (Figure 116, Item 1) on the meter body with four screws (Figure 116, Item 2).

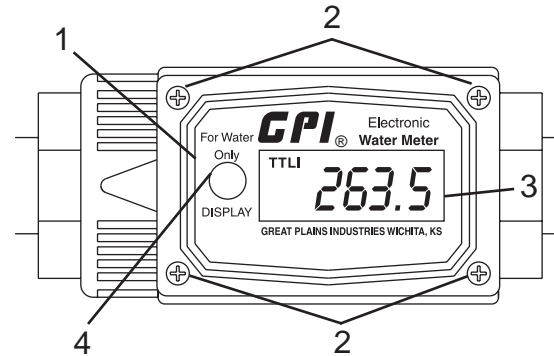

Figure 116

## 5.3 Optional Pusher Axle Maintenance

Refer to the vendor information supplied with the Mixer for maintenance and service information.

## 6.0 Lubrication

### 6.1 Daily Lubrication

Lubricate all the following points with a high-quality EP No. Lithium grease.

Daily lubrication intervals are based on a 10-hour day. If the Mixer is operated more hours per day or double shifted, the maintenance interval must be adjusted accordingly.

### 6.2 Daily Lubrication – Remote Lubrication System (If Equipped)

Mixers may be equipped with a remote lubrication system. This system positions grease fittings in easily accessible groups on the rear pedestal (Figure 117, Item 1), or in an alternate position on the discharge chute support pylon (Figure 118, Item 1). These fittings are connected to mixer components by tubes.

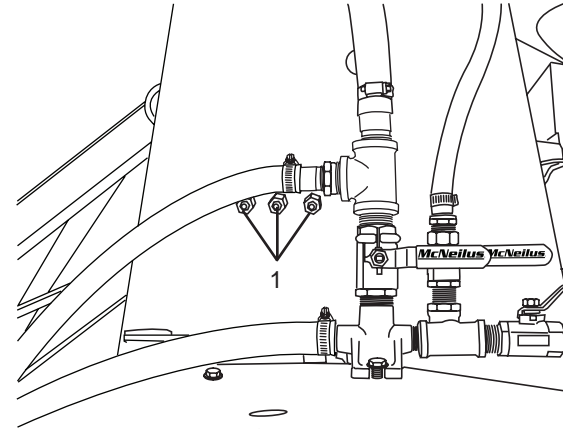

Figure 117  
Standard Location

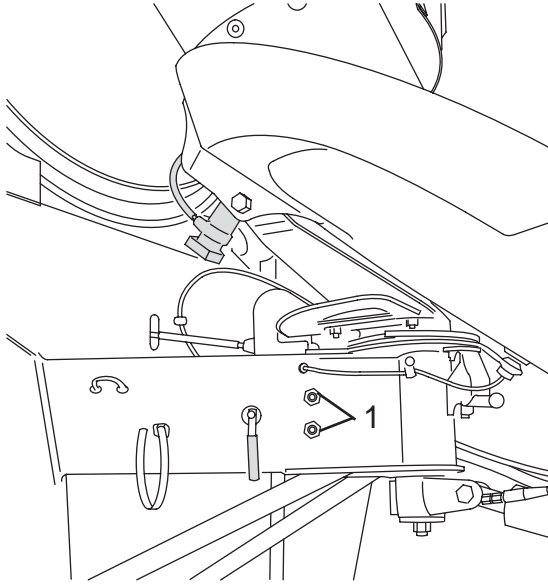

Figure 118  
Alternate Location

### 6.3 Daily Lubrication – Central Lubrication Systems

Mixers may be equipped with one of several central lubrication systems. Refer to the vendor information supplied with the Mixer for operating and maintenance information.

#### **SAFETY NOTICE**

**Before entering the Mixer drum, read and follow OSHA Regulations concerning entry and working in “CONFINED SPACE” OSHA 1910.146 and “LOCKOUT/TAGOUT” OSHA 1910.147.**

**Follow OSHA Regulations while performing any work to the Mixer.**

**Follow all safety instructions in your McNeilus Mixer Manual.**

**Shut off truck engine, lock cab doors, and keep keys in your pocket before entering drum, or performing any work to the Mixer.**

**Place magnetic “DANGER” signs on both cab doors. Failure to do so can result in serious personal injury or death.**

**If you have any questions regarding this notice or require further assistance, call McNeilus Truck and Manufacturing, Inc. at 888-686-7278.**

Daily Lubrication Points		Lubricate Daily or Every 10 Hours	
Ref.	Description	No. of Fittings	Comments
A1	Drum Roller Bearings	2	Two Fittings – One Per Side
A2	Drum Roller Bearings – Remote Lubrication System	2	
A3	Drum Roller Bearings – Remote Lubrication System	2	Alternate Position
B	Drum Roller Track	—	Brush On

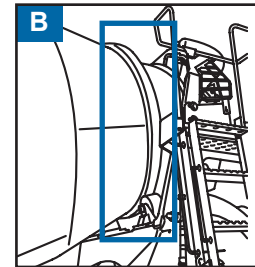
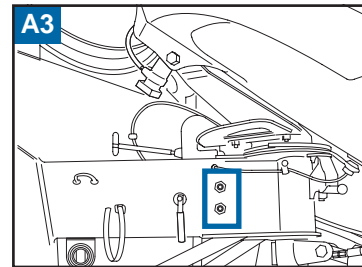
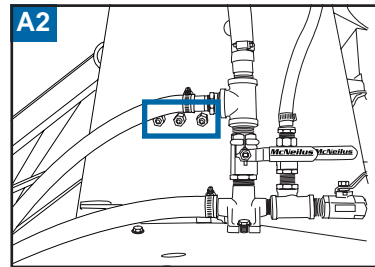
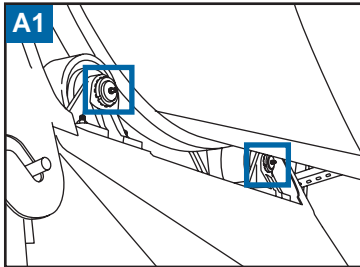
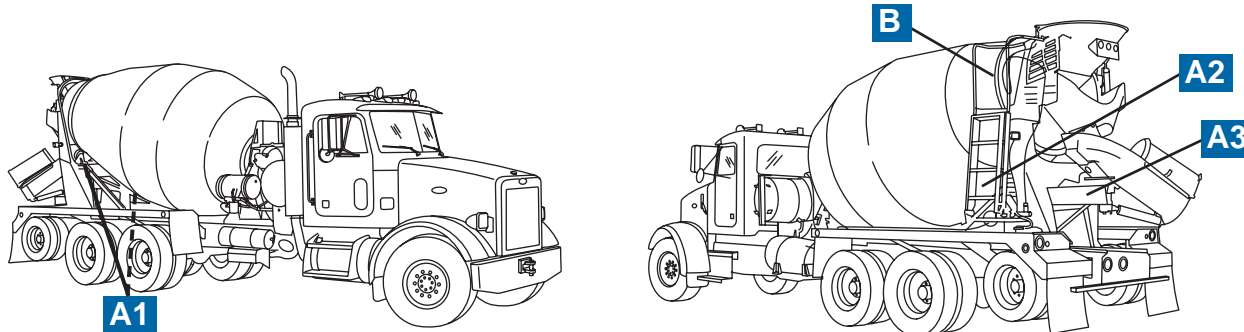

## 6.4 Weekly Lubrication

Lubricate all the following points with a high-quality EP No. 2 Lithium grease.

Daily Lubrication Points		Lubricate Daily or Every 10 Hours	
Ref.	Description	No. of Fittings	Comments
C	PTO Shaft – Slip Joint	1	
C	PTO Shaft – U-Joint	2	Two Fittings – Front and Rear
D1	Main Chute Pivot	1	
D2	Main Chute Pivot – Remote Lubrication System	1	
E	Chute Manual Lock Shaft	—	Apply Grease to Shaft
F	Rear Drum Control Box	2	Two Fittings – One Per Side
G	Knee Braces	4	Two Fittings Per Side. One side called out in truck image below.

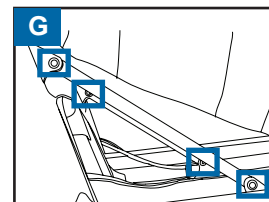
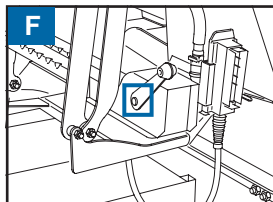
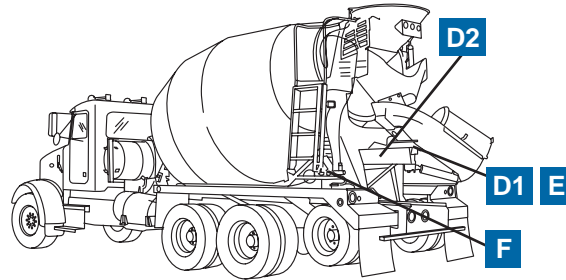
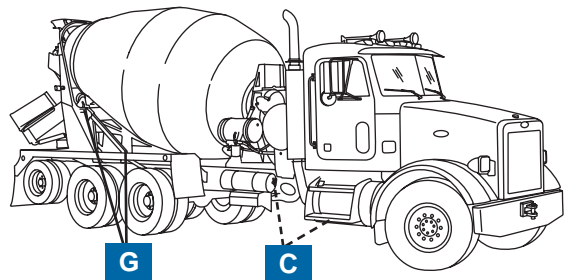
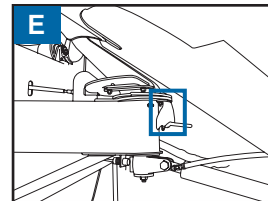
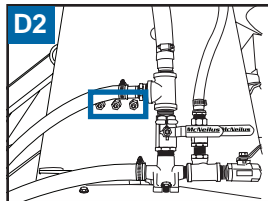
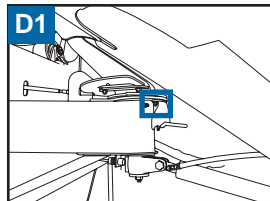
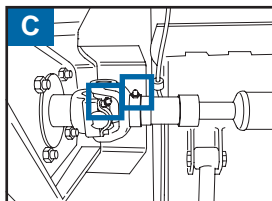

### 6.5 Semi-Annual Lubrication

Lubricate all the following points with a high-quality EP No. 2 Lithium grease.

Daily Lubrication Points		Lubricate Semi-Annually or Every 1250 Hours	
Ref.	Description	No. of Fittings	Comments
H	Drum Control Cables	–	Special Tool Required

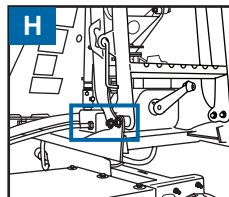
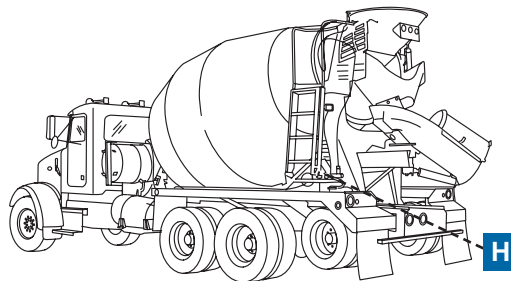

## NOTES

## 1.0 Introduction

When a problem or malfunction occurs, follow these steps. The sequence below will help isolate the problem and often permit a quick repair. If further assistance is required, refer to the applicable section of this manual or contact McNeilus Truck and Manufacturing, Inc. at 888-686-7278.

### **NOTE**

**Isolate the problem before taking any remedial actions.**

1. Unless further damage will occur, repeat the steps that caused the problem. Refer to the Operation section of this manual to be sure that the correct operating procedures have been followed. Often a simple step in the standard operating procedure has been forgotten.
2. Refer to the troubleshooting chart. It is designed to help you troubleshoot problems at your location, and is organized in a logical sequence. Look under the appropriate equipment section, and for the specific problem within the chart.
3. Perform the checkout procedure and remedial actions listed within the chart to isolate the problem.
4. If your particular problem is not listed, or the remedial actions provided do not resolve the problem, we suggest that you take the vehicle to a service shop, refer to the appropriate service manual, or contact McNeilus Truck and Manufacturing, Inc. for service assistance.
5. If you have questions or need help, please contact McNeilus Truck and Manufacturing, Inc. at 888-686-7278.

## 2.0 Troubleshooting Chart

### 2.1 Control System

Problem	Probable Cause	Action
Rotation indications on touch screen display are incorrect and/or backwards.	<ol style="list-style-type: none"> <li>1. Speed sensor failure.</li> <li>2. System error.</li> </ol>	<ol style="list-style-type: none"> <li>1. Check and/or replace speed sensor.</li> <li>2. Call Mixer Service at 507-374-6321.</li> </ol>
Discharge rotation cannot be commanded from the cab keypad, rear pendant, or touch screen display.	<ol style="list-style-type: none"> <li>1. Harness short or open.</li> <li>2. System power failure.</li> <li>3. Coils shorted or open.</li> <li>4. Node (controller) failure.</li> <li>5. Drum stop mode activated.</li> <li>6. Control valve failure.</li> </ol>	<ol style="list-style-type: none"> <li>1. Verify that all wires are securely connected and free of breaks or shorts.</li> <li>2. Check fuses. Check for indicator lights on keypad/pendant and/or node (controller).</li> <li>3. Test and/or replace coils.</li> <li>4. Replace node (controller).</li> <li>5. Make sure drum STOP indicator light is off.</li> <li>6. Replace control valve.</li> </ol>
Discharge rotation cannot be commanded from the cab keypad.	<ol style="list-style-type: none"> <li>1. Cab keypad power loss.</li> <li>2. Loss of cab keypad communications to node (controller).</li> <li>3. Failed button(s) on cab keypad.</li> </ol>	<ol style="list-style-type: none"> <li>1. Check fuse for cab keypad.</li> <li>2. Check error screens for communication loss.</li> <li>3. Replace cab keypad assembly.</li> </ol>
Drum counter does not work.	<ol style="list-style-type: none"> <li>1. Bad speed sensor.</li> <li>2. Drum sensor type set incorrectly.</li> <li>3. System error.</li> </ol>	<ol style="list-style-type: none"> <li>1. Check and/or replace speed sensor.</li> <li>2. Verify drum sensor type and settings in diagnostic screens.</li> <li>3. Call Mixer Service at 507-374-6321.</li> </ol>
Drum rotates automatically upon startup (prior to any input commands).	<ol style="list-style-type: none"> <li>1. Electrical short to control valve coils.</li> <li>2. Stuck control valve.</li> <li>3. System failure.</li> </ol>	<ol style="list-style-type: none"> <li>1. Check wiring and harnesses for shorts.</li> <li>2. Check and/or replace control valves.</li> <li>3. Call Mixer Service at 507-374-6321.</li> </ol>

## 2.2 Electrical System

Problem	Probable Cause	Action
All functions including lights not working	<ol style="list-style-type: none"> <li>1. Battery switch is OFF.</li> <li>2. System problem.</li> </ol>	<ol style="list-style-type: none"> <li>1. Turn battery switch ON.</li> <li>2. Requires shop service and repair.</li> </ol>
All functions except lights not working	<ol style="list-style-type: none"> <li>1. Truck is in lockout/tagout mode.</li> <li>2. Ignition switch is OFF.</li> <li>3. Main fuse blown.</li> <li>4. Open in wiring harness.</li> <li>5. CAN backbone resistance out of spec.</li> <li>6. System problem.</li> </ol>	<ol style="list-style-type: none"> <li>1. Remove lockout/tagout procedure. (See Removing the Lockout/Tagout Procedure.)</li> <li>2. Turn ignition switch ON.</li> <li>3. Replace 60A fuse (F1).</li> <li>4. Inspect harness for wires rubbing or for opens.</li> <li>5. Check CAN backbone resistance (see Service Manual).</li> <li>6. Requires shop service and repair.</li> </ol>
Air chute lock does not engage	<ol style="list-style-type: none"> <li>1. Cab keypad or rear pendant button failure.</li> <li>2. Output failure on node (controller).</li> <li>3. MAC valve failure.</li> <li>4. Chute lock clamp out of adjustment, binding, or failure.</li> <li>5. Bad chute lock quick exhaust valve.</li> <li>6. Faulty DOT hold back valve.</li> </ol>	<ol style="list-style-type: none"> <li>1. Check cab keypad or rear pendant indicator lights. If there are no lights, replace keypad or pendant.</li> <li>2. Check for power output from node (controller).</li> <li>3. Inspect and/or replace MAC valve.</li> <li>4. Adjust chute lock clamp or locking plate.</li> <li>5. Inspect and/or replace quick exhaust valve.</li> <li>6. Check DOT pressure protection valve. Ensure 120 psi at chute lock spring actuator.</li> </ol>
Air chute lock does not disengage.	<ol style="list-style-type: none"> <li>1. Check and/or replace quick exhaust valve.</li> <li>2. Replace spring chamber (DO NOT DISASSEMBLE UNDER ANY CIRCUMSTANCES).</li> <li>3. Replace chute lock clamp plate.</li> <li>4. Replace chute lock clamp assembly.</li> <li>5. Remove concrete buildup.</li> </ol>	<ol style="list-style-type: none"> <li>1. Quick exhaust valve failed.</li> <li>2. Spring chamber failed.</li> <li>3. Groove worn in chute lock clamp plate.</li> <li>4. Chute lock cam worn.</li> <li>5. Concrete buildup interfering with operation.</li> </ol>

Problem	Probable Cause	Action
Optional tag and/or pusher axle(s) do not raise or lower	<ol style="list-style-type: none"> <li>1. Node (controller) output failure.</li> <li>2. MAC valve faulty.</li> <li>3. Quick exhaust valve(s) faulty.</li> <li>4. System problem.</li> </ol>	<ol style="list-style-type: none"> <li>1. Check output at node (controller).</li> <li>2. Inspect and/or replace MAC valve.</li> <li>3. Inspect and/or replace quick exhaust valve.</li> <li>4. Requires shop service and repair.</li> </ol>
CHUTE UP/DOWN does not engage	<ol style="list-style-type: none"> <li>1. Cab keypad or rear pendant failure.</li> <li>2. Bad coil or valve on chute block.</li> <li>3. Faulty cylinder.</li> <li>4. Lack of hydraulic pressure.</li> <li>5. System problem.</li> </ol>	<ol style="list-style-type: none"> <li>1. Check keypad or pendant for indicator lights, and replace if necessary.</li> <li>2. Check and/or replace coil(s) or valve(s) on chute block (see Service Manual).</li> <li>3. Replace cylinder.</li> <li>4. Check system hydraulic pressure.</li> <li>5. Requires shop service and repair.</li> </ol>
Air lift hopper does not function.	<ol style="list-style-type: none"> <li>1. Output failure at node (controller).</li> <li>2. Faulty MAC valve.</li> <li>3. Leaking or bad cylinder.</li> <li>4. Leaky or broken airline.</li> <li>5. System configuration error.</li> </ol>	<ol style="list-style-type: none"> <li>1. Check output at node (controller).</li> <li>2. Inspect and/or replace MAC valve.</li> <li>3. Inspect and/or replace cylinder.</li> <li>4. Inspect airlines to air lift hopper cylinder.</li> <li>5. Check system configuration (Fleet Manager function).</li> </ol>
Optional CHUTE SWING does not operate	<ol style="list-style-type: none"> <li>1. Hydraulic control valve inoperative.</li> <li>2. Crossover relief set incorrectly.</li> <li>3. Solenoid or coil failure.</li> <li>4. System pressure too low.</li> <li>5. System problem.</li> </ol>	<ol style="list-style-type: none"> <li>1. Check for 12 volts at valve.</li> <li>2. Adjust crossover relief (see Service Manual).</li> <li>3. Check and/or replace coil(s) or solenoid valve(s).</li> <li>4. Check system pressure.</li> <li>5. Requires shop service and repair.</li> </ol>

## 2.3 Water System – Pressurized

Problem	Probable Cause	Action
Water does not discharge or discharges slowly	<ol style="list-style-type: none"> <li>1. Water tank is not pressurized.</li> <li>2. Insufficient air pressure.</li> <li>3. Tank discharge valve not open.</li> <li>4. Leak in water line.</li> <li>5. Restriction in water line or shut-off valve.</li> <li>6. Water is frozen.</li> <li>7. System problem.</li> </ol>	<ol style="list-style-type: none"> <li>1. Pressurize water tank.</li> <li>2. Requires shop service and repair.</li> <li>3. Open tank discharge valve.</li> <li>4. Locate and repair leak.</li> <li>5. Requires shop service and repair.</li> <li>6. Place Mixer in heated building.</li> <li>7. Requires shop service and repair.</li> </ol>
Unable to maintain air pressure in water tank	<ol style="list-style-type: none"> <li>1. Faulty DOT hold back valve.</li> <li>2. Faulty water tank regulator.</li> <li>3. Faulty overpressure protection device.</li> </ol>	<ol style="list-style-type: none"> <li>1. Inspect and/or replace hold back valve.</li> <li>2. Inspect and/or replace tank regulator.</li> <li>3. Inspect and/or replace overpressure protection valve.</li> </ol>

## 2.4 Water System – Pump

Problem	Probable Cause	Action
Water does not discharge or discharges slowly	<ol style="list-style-type: none"> <li>1. Air supply to pump is not open/pump not running.</li> <li>2. Insufficient air pressure.</li> <li>3. Valve from tank is not open.</li> <li>4. Leak in water line.</li> <li>5. Restriction in water line or shut-off valve.</li> <li>6. Water is frozen.</li> <li>7. System problem.</li> </ol>	<ol style="list-style-type: none"> <li>1. Open air valve.</li> <li>2. Wait for chassis air pressure to reach 100 psi (689 kPa).</li> <li>3. Open valve.</li> <li>4. Locate and repair leak.</li> <li>5. Requires shop service and repair.</li> <li>6. Place Mixer in heated building.</li> <li>7. Requires shop service and repair.</li> </ol>

## 2.5 Pneumatic System

Problem	Probable Cause	Action
Air accessories (hopper, chute lock) are sluggish, sticky, or slow to respond.	<ol style="list-style-type: none"> <li>1. Faulty DOT hold back valve.</li> <li>2. Plugged coalescing filter.</li> <li>3. Excess water in air system.</li> <li>4. MAC valves sticky and/or failed.</li> <li>5. Insufficient truck air pressure.</li> <li>6. Leaks or broken airlines to function.</li> </ol>	<ol style="list-style-type: none"> <li>1. Inspect and/or replace DOT hold back valve.</li> <li>2. Drain water from coalescing filter and change the element.</li> <li>3. Drain water/moisture from all air tanks.</li> <li>4. Lubricate or replace MAC valves.</li> <li>5. Have truck compressor serviced.</li> <li>6. Inspect and/or replace faulty/leaking airlines.</li> </ol>

## 2.6 GPI® Water Meter

Problem	Probable Cause	Action
Display dim or blank	Batteries weak, dead, or missing. Battery terminals corroded. System problem.	Replace batteries. (See Battery Replacement.) Clean battery terminals. Requires shop service and repair.
Meter is not accurate	System problem.	Requires shop service and repair.

## 2.7 BR Industries Water Meter (Optional)

Problem	Probable Cause	Action
Flow through meter restricted	<ol style="list-style-type: none"> <li>1. Screen in input side of water meter clogged.</li> </ol>	<ol style="list-style-type: none"> <li>1. Replace screen.</li> </ol>
Meter does not function	<ol style="list-style-type: none"> <li>1. System problem.</li> </ol>	<ol style="list-style-type: none"> <li>1. Requires shop service and repair.</li> </ol>

## 2.8 UFM Water Meter

<b>Problem</b>	<b>Probable Cause</b>	<b>Action</b>
Meter does not function	1. System problem.	1. Requires shop service and repair.

**This Page Intentionally Left Blank**

## 1.0 Instruments and Controls

If your Mixer is equipped with electronic controls (not touch screen controls), the following figures and tables identify and describe the electronic controls. These instructions include optional features that may or may not be included on your Mixer.

To make sure you understand proper operating procedures, read this section and carefully practice with the controls and instruments to learn how to safely operate the equipment.

### 1.1 Cab Controls

The in-cab controls are located on the mixer console between the seats (Figure 1).

The control box contains rocker switches, displays for the various mixer functions, lights, and options. The control box also contains a fuse panel.

No.	Position	Normal Use or Reading
1	Fuse Panel	Contains fuses for the mixer function electrical circuits.
2	Control Box	Controls drum, chute, and accessory functions. Contains various indicator lights and displays.
3	Drum Control Lever (CHARGE/ DISCHARGE)	Controls the drum rotation direction and speed.

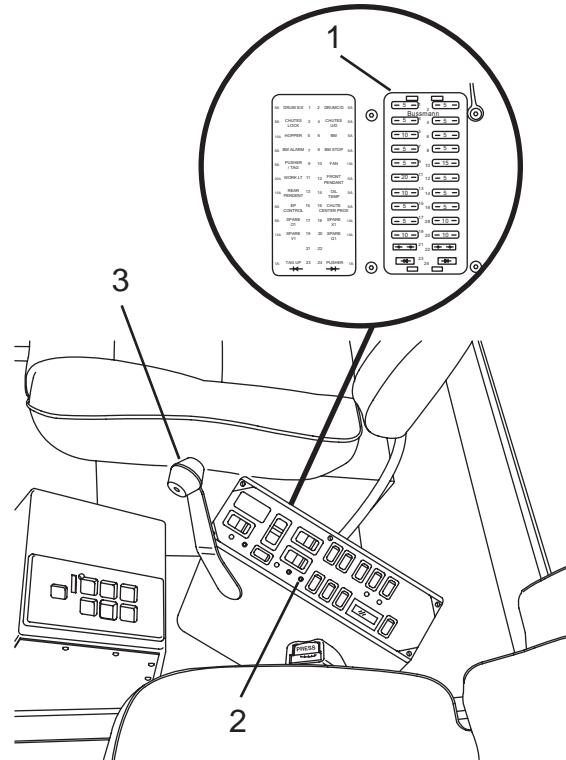

Figure 1

## 1.1.1 Rocker Switch Functions

Accessories and mixer functions and some options are operated by rocker switches on the top of the control box (Figure 2). The actual switches present in the control box will vary, depending on the configuration of your Mixer.

No.	Item	Description
1	DRUM START/STOP Rocker Switch	Press the switch to start or stop drum functions. <sup>1</sup>
2	CHUTE UP/DOWN Rocker Switch	Select UP to raise the main chute. Select DOWN to lower the main chute.
3	CHUTE SWING Rocker Switch (OPTIONAL)	Press and hold the right side of the switch to move the chute to the right. Press and hold the left side of the switch to move the chute to the left.
4	PUSHER Rocker Switch (OPTIONAL)	Select DOWN to lower the pusher axle(s). Select UP to raise the pusher axle(s). <sup>2</sup>
5	BRIDGEMASTER ACTIVATE Rocker Switch	Not applicable.
6	BRIDGEMASTER UP/DOWN Rocker Switch	Not applicable.

No.	Item	Description
7	BRIDGEMASTER START/STOP Rocker Switch (OPTIONAL)	Not applicable.
8	ADD WATER Rocker Switch (OPTIONAL)	Press the switch to add water to the concrete mix in the drum. (See Remote Water Injection System for more information.)
9	WORK LIGHT Rocker Switch (OPTIONAL)	Select ON to activate the work lights. Select OFF to deactivate the work lights.
10	HOPPER Rocker Switch (OPTIONAL)	Press the switch to swing the air flip-up hopper up or down.
11	CHUTE LOCK Rocker Switch (OPTIONAL)	Press the switch to engage or disengage the chute air lock.

<sup>1</sup> The function triggered by the switch will depend on the current state of that device. (Example: If the charge hopper is up, activating the switch will lower it.)

<sup>2</sup> The pusher axle(s) will automatically rise when the truck is placed in reverse. (See Pusher Axles.)

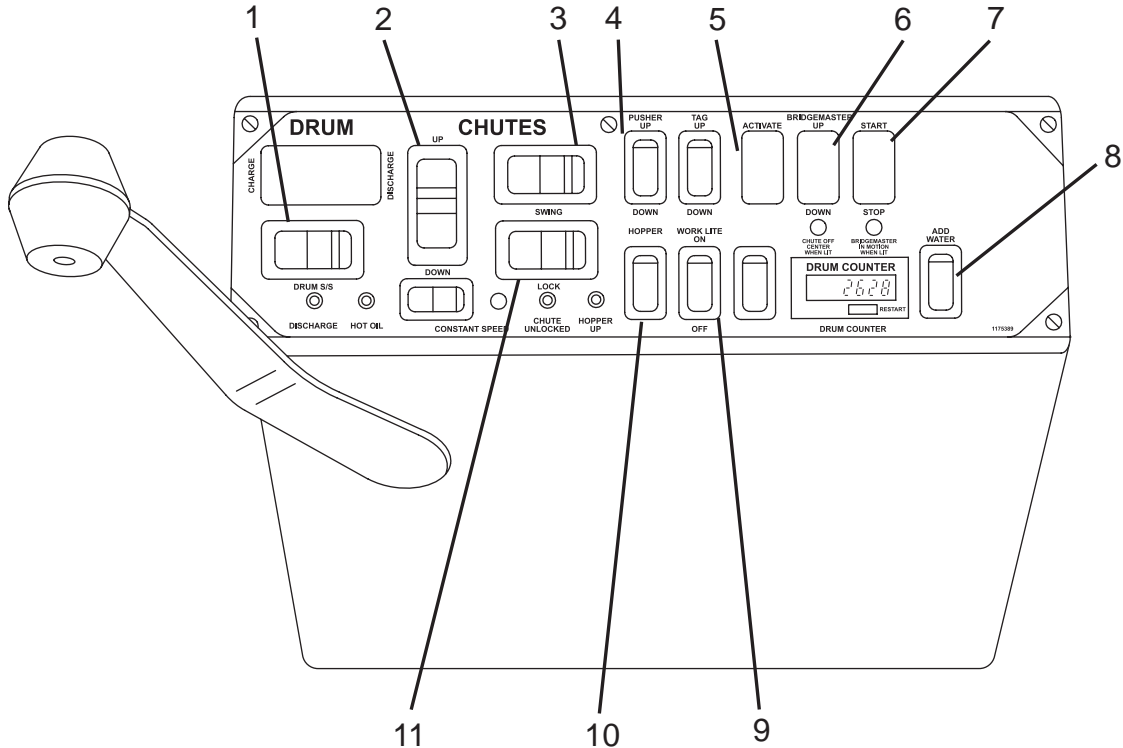

Figure 2

## 1.1.2 Indicator Light and Display Functions

The indicator lights and displays (Figure 3) are used to display the status of various functions. The actual indicator lights present in the control box will vary, depending on the configuration of your Mixer.

No.	Item	Operation
1	HOT OIL Indicator Light	Light indicates when the hydraulic oil reaches 215°F (102°C).
2	CHUTE OFF CENTER WHEN LIT Indicator Light	Light indicated when the discharge chute is off the center position.
3	BRIDGEMASTER IN MOTION WHEN LIT	Not applicable.
4	DRUM COUNTER Display	Counts the number of revolutions of the mixer drum in either direction. Push the button to reset.
5	HOPPER UP Indicator Light (OPTIONAL)	Light indicates when the flip-up charge hopper is in the raised position.
6	CHUTE UNLOCKED Indicator Light (OPTIONAL)	Light indicates when the main chute is unlocked.

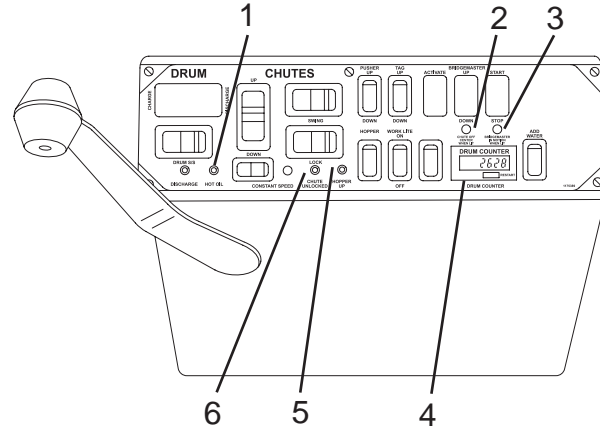

Figure 3

## 1.2 Fuse Functions

If a function in the cab pendant controls or rear pendant controls does not operate, check the condition of the fuses (Figure 4) located in the cover of the control fuse box (in the cab control pendant) or the rear of the control box (cab control box). A label is located beside the fuses to identify the functions they control.

**CAUTION**

**Do not replace a fuse with a higher amperage fuse than is listed for the location. Always use new fuses of the correct amperage.**

**Using a fuse with a higher amperage may cause damage to the equipment.**

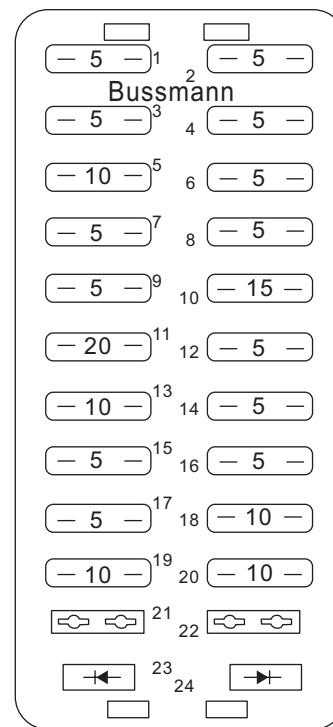

Figure 4

Fuse No.	Amperage Rating	Description
1	5 amp	DRUM S/S (Start/Stop) (OPTIONAL)
2	5 amp	DRUM C/D (Charge/Discharge)
3	5 amp	CHUTE LOCK (OPTIONAL)
4	5 amp	CHUTE U/D (Up/Down)
5	10 amp	HOPPER (OPTIONAL)
6	5 amp	BM - Not applicable.
7	5 amp	BM ALARM - Not applicable.
8	5 amp	BM STOP - Not applicable.
9	5 amp	PUSHER/TAG (OPTIONAL)
10	15 amp	FAN
11	20 amp	WORK LT (OPTIONAL)
12	5 amp	FRONT PENDANT (Cab Control Box)
13	10 amp	REAR PENDANT
14	5 amp	OIL TEMP
15	5 amp	Not Used
16	5 amp	Not Used
17	5 amp	Spare Power 01
18	10 amp	Spare Power X1
19	10 amp	Strobe Power (OPTIONAL)
20	10 amp	Spare Power Q1
21	N/A	Not Used

Fuse No.	Amperage Rating	Description
22	N/A	Work Light in Reverse Diode
23	N/A	Tag Up Diode
24	N/A	Pusher Up Diode

### 1.3 Outside Controls

The outside controls consist of an optional rear pendant (Figure 5, Item 1), a manual chute lock (Figure 5, Item 2), and drum cable control (Figure 5, Item 3).

No.	Item	Description
1	Rear Control Pendant	Contains toggle switches to control various mixer functions. The controls contained will vary, depending on options.
2	Manual Chute Lock	Mechanically locks the main chute in one of several positions.
3	Drum Control	Contains the drum control lever that controls the speed and direction of the drum rotation. Early models may also contain toggle switches to control various mixer functions. The controls contained will vary, depending on options.

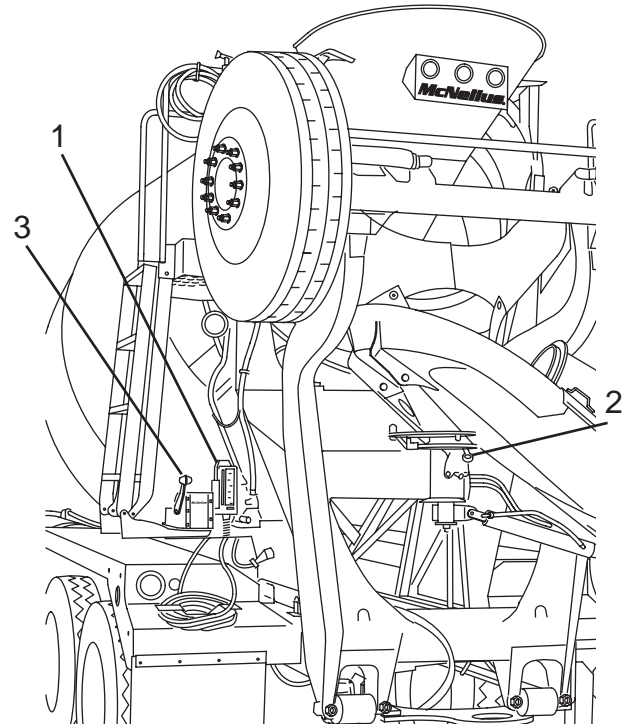

Figure 5

## 1.3.1 Rear Control Pendant

The rear pendant (Figure 6) contains toggle switches to control various mixer functions. The actual switches present in the rear pendant will vary, depending on the configuration of your Mixer.

No.	Control	Normal Use or Reading
1	THROTTLE Toggle Switch (OPTIONAL) <sup>1</sup>	Push to increase or decrease throttle speed. (See Adjusting the Throttle Speed for more information.)
2	HOPPER Toggle Switch (OPTIONAL)	Push the switch to move the flip-up charge hopper up or down. <sup>2</sup>
3	CHUTE LOCK Toggle Switch (OPTIONAL)	Push the switch to activate or deactivate the main chute air lock. <sup>2</sup>
4	CHUTE UP/DOWN Toggle Switch	Push and hold the switch to the right to raise the main chute. Push and hold the switch to the left to lower the main chute.
5	CHUTE SWING Toggle Switch (OPTIONAL)	Push the switch to the right to swing the chute to the right. Push the switch to the left to swing the chute to the left.
6	DRUM S/S (START/STOP) Toggle Switch	Push the switch to start or stop drum functions.

<sup>1</sup> The chassis cruise control must be in the ON position, the parking brake must be applied, and the automatic transmission must be in NEUTRAL.

<sup>2</sup> The function triggered by the switch will depend on the current state of that function. (Example: If the charge hopper is up, activating the switch will lower it.)

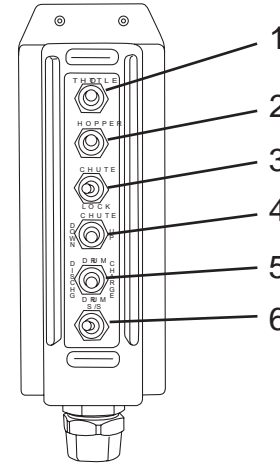

Figure 6

- 1.3.1.1 By-Passing the Rear Pendant

If the rear pendant (Figure 7, Item 1) is lost, or becomes damaged or faulty, a jumper plug (Figure 7, Item 3) must be installed in the rear pendant socket to allow operation of control functions from the cab control box.

Contact McNeilus Parts and Service at 888-686-7278 for jumper plug part numbers.

1. Turn truck ignition switch OFF. (Refer to the Operator's Manual supplied by the chassis supplier for all shut-down and parking procedures.)
2. Disconnect the rear pendant harness connector (Figure 7, Item 2) from the rear pedestal.
3. Install a jumper plug (Figure 7, Item 3) into the rear pendant socket.
4. Start the truck.
5. Operate the mixer functions using the cab control box.

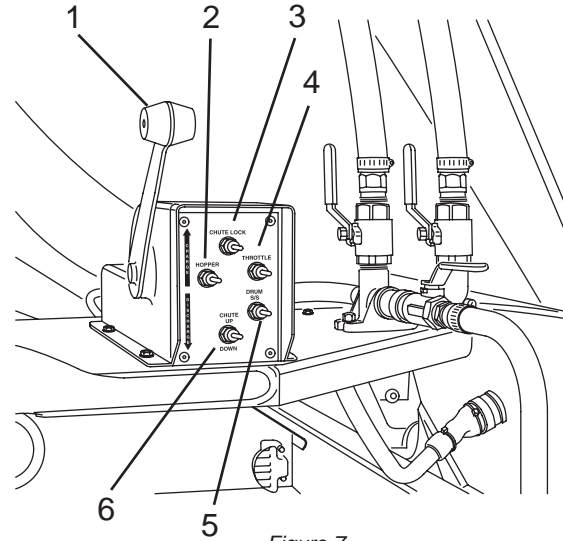

Figure 7

## 1.3.2 Drum Control

The rear drum control (Figure 8) and toggles switches control various mixer functions.

No.	Control	Normal Use or Reading
1	DRUM CONTROL LEVER (CHARGE/DISCHARGE)	<p>Starting at the NEUTRAL position, pushing the lever forward (away from the operator) starts the drum rotating in the CHARGE direction. The farther the lever is pushed forward, the faster the drum rotates.</p> <p>Pulling the lever back (toward the operator) will decrease the drum speed until the NEUTRAL position is reached at which point the drum stops rotating.</p> <p>From the NEUTRAL position, pulling lever back (toward the operator) will start the drum rotating in the DISCHARGE direction. The farther the lever is pulled back, the faster the drum rotates.</p>
2	HOPPER Toggle Switch (OPTIONAL)	Push the switch to move the flip-up charge hopper up or down. <sup>1</sup>
3	CHUTE LOCK Toggle Switch (OPTIONAL)	Push the switch to activate or deactivate the main chute air lock. <sup>1</sup>
4	THROTTLE Toggle Switch (OPTIONAL)	Push to increase or decrease throttle speed. (See Adjusting the Throttle Speed for more information.)

No.	Control	Normal Use or Reading
5	DRUM S/S (START/STOP) Toggle Switch	Push the switch to start or stop drum functions.
6	CHUTE UP/DOWN Toggle Switch	<p>Push and hold the switch to the UP position to raise the main chute.</p> <p>Push and hold the switch to the DOWN to lower the main chute.</p>

<sup>1</sup> The function triggered by the switch will depend on the current state of that function. (Example: If the charge hopper is up, activating the switch will lower it.)

<sup>2</sup> The chassis cruise control must be in the ON position, the parking brake must be applied, and the automatic transmission must be in NEUTRAL.

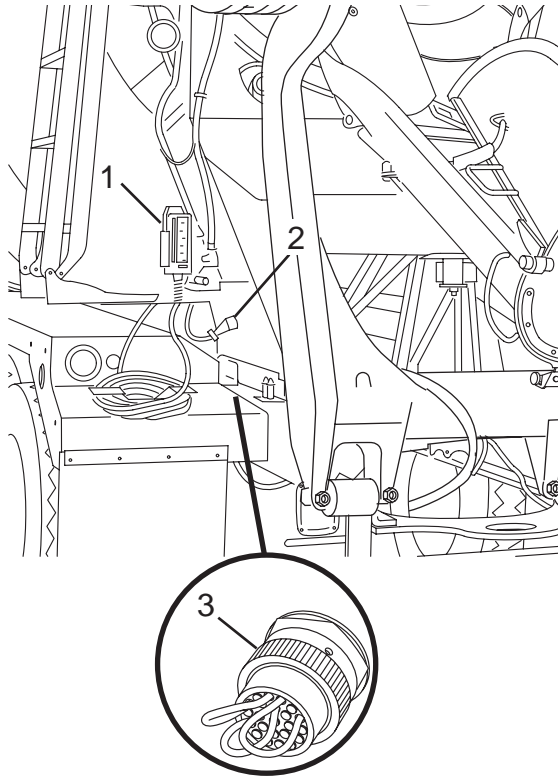

Figure 8

### 1.4 OMNEX® Wireless Remote Control (Optional)

The OMNEX® Wireless Remote Control system consists of a transmitter, and a receiver that is connected to the mixer electronic control system.

#### 1.4.1 OMNEX® Wireless Remote Control (Cab Console Version)

The transmitter (Figure 9, Item 1) when not in use is stored in the docking cradle (Figure 9, Item 2). The cradle will automatically charge the transmitter whenever the transmitter is placed in the cradle.

The transmitter is equipped with a battery-saving feature. If the transmitter is inactive for ten minutes, the transmitter will shut itself off (the receiver will then also shut off all outputs). Pressing any of the buttons momentarily before shut-down will reset the ten-minute timer.

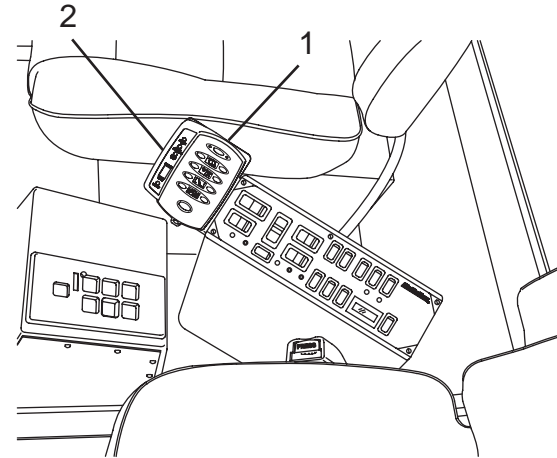

Figure 9

• 1.4.1.1 Control Buttons and Switches

**NOTE**

**Transmitter buttons 5, 6, and 7 have alternate functions. The alternate functions are accessed by pressing and holding the green power button after the system is turned on.**

Mixer functions can be operated by the control buttons on the transmitter and docking cradle (Figure 10), as well as the switches on the cab control console.

No.	Control	Normal Use or Reading
1	DRUM CHARGE Button	Non Functioning
2	Power ON Button	Press to turn the system ON.
	SHIFT SELECT Button (Press and Hold)	Once the system has been activated, pressing and holding the button allows buttons 4, 5, and 10 to operate in the alternate function (lower icon).
3	DRUM DISCHARGE Button <sup>1</sup>	Non Functioning
4	THROTTLE RETARD Button <sup>2</sup> (Primary Function)	Press to retard throttle/drum speed. (See "Adjusting the Throttle Speed" for more information.)
	HOPPER UP/DOWN Button <sup>3</sup> (Alternate Function)	Press to raise or lower the charge hopper. <sup>4</sup>

No.	Control	Normal Use or Reading
5	CHUTE DOWN Button (Primary Function)	Press and hold to lower the discharge chute.
	CHUTE SWING (RIGHT) Button <sup>2</sup> (Alternate Function)	Press and hold to swing the discharge chute to the right.
6	CHUTE LOCK/ UNLOCK Button	Press to engage the chute lock. <sup>3</sup> Press the button again to disengage the chute lock.
7	Power OFF Button	Press to turn the system OFF. The drum will stop if it was rotating when the button was pressed.
8	DRUM STOP Button	Press to stop drum rotation. <sup>3</sup>
9	CHARGE/ DISCHARGE Button (Located on Docking Cradle)	Non Functioning
10	CHUTE UP Button (Primary Function)	Press and hold to raise the discharge chute.
	CHUTE SWING (LEFT) Button <sup>2</sup> (Alternate Function)	Press and hold to swing the discharge chute to the left.
11	THROTTLE ADVANCE Button	Press to advance throttle/drum speed. (See "Adjusting the Throttle Speed" for more information.)

<sup>1</sup> If the DRUM DISCHARGE button is pressed while the drum is rotating in the Charge direction, the drum will slow before rotating in the Discharge direction.

<sup>2</sup> The chassis cruise control must be in the ON position, the parking brake must be applied, and the automatic transmission must be in NEUTRAL.

<sup>3</sup> To activate the alternate function, press and hold the Power ON/SHIFT SELECT button.

<sup>4</sup> The function triggered by the switch will depend on the current state of that function. (Example: If the charge hopper is up, activating the switch will lower it.)

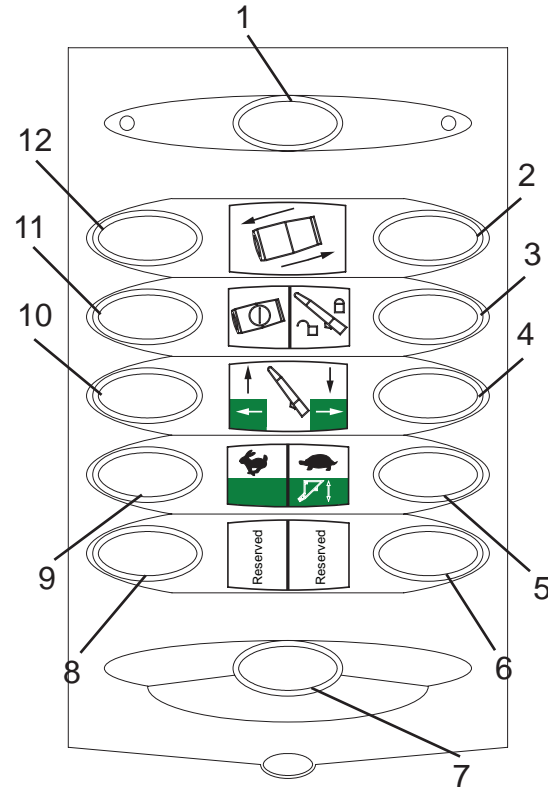

Figure 10

**1.4.2 LED Indicators**

The Battery Low (Figure 11, Item 1) and Active (Figure 11, Item 2) LED indicators on the transmitter are used to indicate the status of the transmitter.

Both of the LED indicators can display one of three colors (red, green, or yellow), and may operate in a solid, or in slow-flash or fast-flash display mode.

The combination of indicators activated, colors, and display modes are used to display transmitter status or display the fault code. (See Diagnostic Codes - Transmitter.)

No.	Control	Normal Use or Reading
1	Battery Low LED	The indicator is ON when the batteries are low. The LED is also used to display diagnostic codes.
2	Active LED	The LED indicates that there is activity between the transmitter and receiver. The LED is also used to display diagnostic codes.
3	BATTERY	The indicator is ON when the transmitter is installed in the docking cradle to indicate that the batteries are being recharged.
4	DRUM STOP	The indicator is ON when the drum rotation is stopped.
5	CHUTE UNLOCKED	The light indicates that the chute lock is unlocked.
6	HOPPER UP	The light indicates that the hopper is in the UP position.

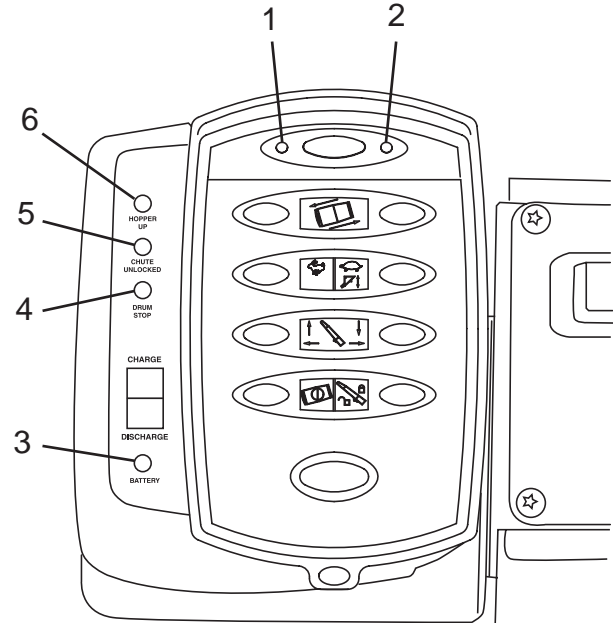

Figure 11

### 1.4.3 OMNEX® Wireless Remote Control (Plug and Play Version)

The OMNEX® Wireless Remote Control system consists of a transmitter, and a receiver that is connected to the mixer electronic control system. The “Plug and Play” version of the OMNEX Wireless Remote Control system uses a receiver (Figure 12, Item 1) that plugs into the rear pendant connector in place of the rear pendant.

A portable transmitter is used to input commands to the mixer system. The transmitter is equipped with a battery-saving feature. If the transmitter is inactive for ten minutes, the transmitter will shut itself off (the receiver will then also shut off all outputs). Pressing any of the buttons momentarily before shut-down will reset the ten-minute timer.

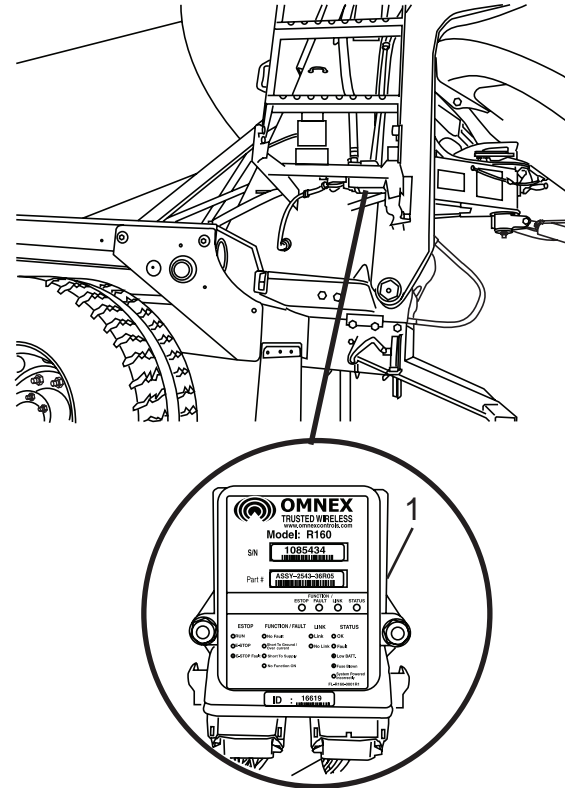

Figure 12

**1.4.4 Transmitter**

- **1.4.4.1 Control Buttons**

Mixer functions can be operated by the control buttons on the transmitter (Figure 13).

No.	Control	Normal Use or Reading
1	POWER ON Button	Press to turn the system ON.
2	CHUTE LOCK Button	Press to lock the chute lock. Press the button again to unlock the chute lock.
3	DRUM DISCHARGE Button <sup>1</sup>	Non Functioning
4	CHUTE DOWN Button	Press and hold to lower the discharge chute.
5	SPARE	Not Used.
6	THROTTLE DOWN Button <sup>2</sup>	Press to retard throttle/drum speed. (See "Adjusting the Throttle Speed" for more information.)
7	POWER OFF Button	Press to turn the system OFF.
8	THROTTLE UP Button <sup>2</sup>	Press to advance throttle/drum speed. (See "Adjusting the Throttle Speed" for more information.)
9	HOPPER Button	Press to raise or lower the charge hopper. <sup>3</sup>
10	CHUTE UP Button	Press and hold to raise the discharge chute.

No.	Control	Normal Use or Reading
11	DRUM CHARGE Button	Non Functioning
12	DRUM START/STOP Button	Press to start drum rotation. Press the button again to stop drum rotation.

<sup>1</sup> If the DRUM DISCHARGE button is pressed while the drum is rotating in the CHARGE direction, the drum will slow before rotating in the DISCHARGE direction.

<sup>2</sup> The chassis cruise control must be in the ON position, the parking brake must be applied, and the automatic transmission must be in NEUTRAL.

<sup>3</sup> The function triggered by the switch will depend on the current state of that function. (Example: If the charge hopper is up, activating the switch will lower it.)

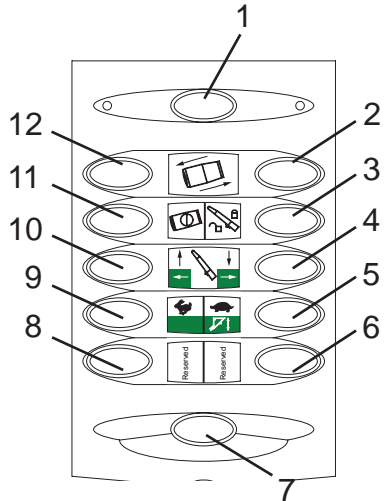

Figure 13

- 1.4.4.2 LED Indicators

The Battery Low (Figure 14, Item 1) and Active (Figure 14, Item 2) LED indicators on the transmitter are used to indicate the status of the transmitter.

Both LED indicators can display one of three colors (red, green, or yellow), and may operate in a solid, or in slow-flash or fast-flash display mode.

The combination of indicators activated, colors, and display modes are used to display transmitter status or display the fault code. (See “Diagnostic Codes - Transmitter.”)

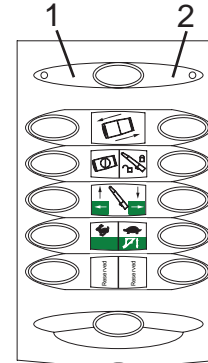

Figure 14

No.	Control	Normal Use or Reading
1	Battery Low LED	The indicator is ON when the batteries are low. The LED is also used to display diagnostic codes.
2	Active LED	The LED indicates that there is activity between the transmitter and receiver. The LED is also used to display diagnostic codes.

### 1.4.5 Cleaning the Transmitter

**⚠ CAUTION**

**Do not clean the transmitter or receiver using high pressure.**

**If water or other liquids get inside the transmitter battery compartment or receiver, immediately dry the unit. Remove the case and allow it to air dry before use.**

**Failure to comply may result in damage to equipment.**

Use a damp cloth to clean the transmitter unit after operation. Remove mud, dirt, concrete, etc. from the transmitter to prevent clogging of buttons.

### 1.4.6 OMNEX<sup>®</sup> Wireless Remote Control (Optional) Troubleshooting

#### • 1.4.6.1 Diagnostic Codes – Transmitter

1. The Battery Low (Figure 15, Item 1) and Active (Figure 15, Item 2) LED indicators on the transmitter are used to indicate the status of the transmitter.
  2. Both of the LED indicators can display one of three colors (red, green, or yellow), and may operate in a solid, or in slow-flash or fast-flash display modes.
3. The combination of indicators activated, colors, and display modes are used to display transmitter status or display the fault code.

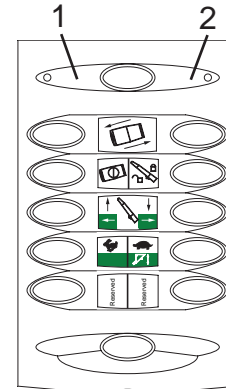

Figure 15

<b>LED Indicator Activity</b>	<b>Status/Fault</b>	<b>Action</b>
Battery Low LED: OFF Active LED: ON – Solid	Occurs whenever a function is pressed. Will also remain on momentarily during power-up.	None required – Normal operation.
Battery Low LED: OFF Active LED: ON – Slow Flash	Transmitter is in download mode.	Turn transmitter OFF and back ON again.
Battery Low LED: OFF Active LED: ON – Fast Flash	Transmitter is in operating mode.	None required – Normal operation.
Battery Low LED: ON – Slow Flash Active LED: ON – Fast Flash	Low battery.	Replace batteries. (See Battery Replacement–Plug and Play Version.) Recharge batteries by placing the transmitter in the docking cradle (cab control box version).
Battery Low LED: ON – Fast Flash (10 seconds) Active LED: OFF	Transmitter failure.	Requires shop service and repair.
Battery Low LED: ON – Slow Flash Active LED: ON – Slow Flash	Stuck button detected.	Turn power off. Depress all buttons several times to free the stuck button. Turn power on and check button functions. If problem cannot be cleared, shop service is required.
On Power Down – Only: Battery Low LED: ON – Slow Flash Active LED: ON – Slow Flash	Unit still under power; a stuck button may be detected.	Turn power off. Depress all buttons several times to free the stuck button. Turn power on and check button functions. If a problem cannot be cleared, shop service is required.
Battery Low LED: ON – Fast Flash Active LED: ON – Fast Flash	Transmitter is in configuration mode.	Requires shop service and repair.
Battery Low LED: ON – Solid Active LED: ON – Solid	Transmitter is downloading ID code.	Requires shop service and repair.

## 1.4.7 Receiver Locations

If the Mixer does not respond to commands from the transmitter, the receiver may need to be accessed to check diagnostic codes.

Depending on the version of the wireless remote installed, the location of the receiver will vary.

**Cab Control Box Version:** The receiver is located in the control box (cab control box) (Figure 16, Item 1).

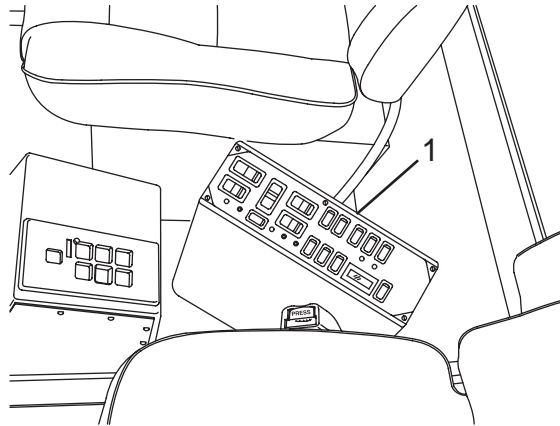

Figure 16

- 1.4.7.1 LED Indicators

LED indicators (Figure 17, Item 1) are used to indicate the operational status of the receiver. The LED indicators are also used to diagnose transmitter problems.

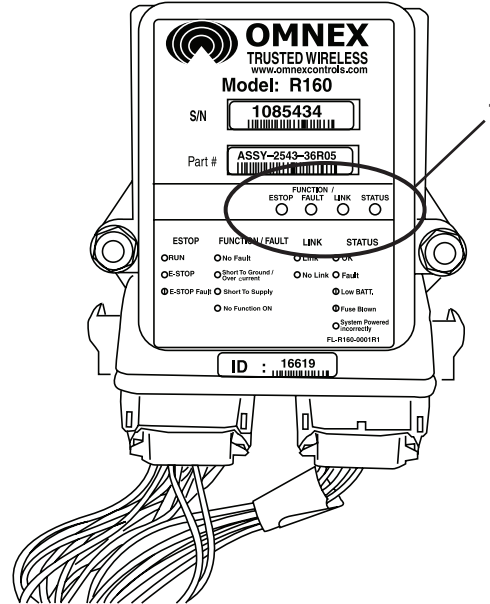

Figure 17

- 1.4.7.2 Normal Operation

LED Indicator Activity	Transmitter Status	Receiver Status
E-STOP: ON – Solid Red FAULT: OFF LINK: ON – Solid Red STATUS: ON – Solid Green	Transmitter: OFF	The receiver is operating properly.
E-STOP: ON – Solid Green FAULT: OFF LINK: ON – Green – Fast Flash STATUS: ON – Solid Green	Transmitter: ON	The receiver is operating properly.
E-STOP: ON – Solid Green FAULT: ON – Solid Green LINK: ON – Green – Fast Flash STATUS: ON – Solid Green	Transmitter: In operation	The receiver is operating properly.
E-STOP: ON – Solid Red FAULT: ON – Solid Green LINK: ON – Solid Red STATUS: ON – Solid Green	Transmitter: OFF	When a latched function is activated when the transmitter is turned off, the FAULT light will stay green. The receiver is operating properly. If the FAULT light is not green, service is required.

- 1.4.7.3 Fault Codes

**NOTE:** In some cases, the LED indicators will vary, depending on whether the transmitter is ON or OFF. See the transmitter status in the “Status/Fault” column in the chart in the pages below.

LED indicators (Figure 18, Item 1) are used to display the receiver fault codes.

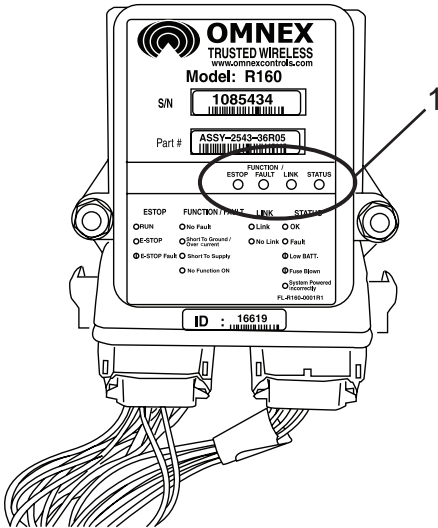

Figure 18

LED Indicator Activity	Status/Fault	Action
E-STOP: ON – Solid Red FAULT: OFF LINK: ON – Solid Red STATUS: ON – Solid Green	Transmitter: ON Receiver is not receiving a signal from the transmitter	Transmitter does not match receiver. Use correct transmitter. If transmitter matches receiver, the receiver requires shop service and repair.
E-STOP: ON – Solid Green FAULT: OFF LINK: ON – Green – Fast Flash STATUS: ON – Green – Slow Flash	Transmitter: ON A low battery condition has been detected	Replace batteries (Plug and Play Version). (See Battery Replacement – Plug and Play Version.) Recharge batteries (cab control box version). If fault code still displays after the batteries have been replaced, shop service and repair is required.
E-STOP: ON – Red – Slow Flash FAULT: OFF LINK: ON – Green – Fast Flash STATUS: ON – Solid Red	Transmitter: ON Short detected in E-STOP circuit	Requires shop service and repair.
E-STOP: ON – Solid Green FAULT: ON – Solid Red LINK: ON – Green – Fast Flash STATUS: ON – Solid Red	Transmitter: ON A short to ground or excessive current load has been detected	Requires shop service and repair.
E-STOP: ON – Solid Red FAULT: ON – Red – Slow Flash LINK: ON – Red – Fast Flash STATUS: ON – Solid Red	Transmitter: ON E-STOP output not properly connected	Requires shop service and repair.
E-STOP: ON – Solid Red FAULT: ON – Red – Slow Flash LINK: ON – Solid Red STATUS: ON – Solid Red	Transmitter: OFF A wiring short to the battery has been detected	Requires shop service and repair.

LED Indicator Activity	Status/Fault	Action
E-STOP: ON – Solid Red FAULT: OFF LINK: ON – Solid Red STATUS: ON – Solid Red	Transmitter: OFF Internal fault detected in receiver	Requires shop service and repair
E-STOP: ON – Solid Red FAULT: OFF LINK: ON – Solid Red STATUS: ON – Red – Slow Flash	Transmitter: OFF Blown fuse detected	Replace fuse. (See Fuse Functions.)
E-STOP: ON – Solid Green FAULT: OFF LINK: ON – Red – Fast Flash STATUS: ON – Red – Fast Flash	Transmitter: ON Set-up mode failure	Requires shop service and repair
E-STOP: ON – Solid Red FAULT: ON – Red – Slow Flash LINK: ON – Solid Red STATUS: ON – Alternating Red/Green – Fast Flash	Transmitter: OFF Receiver powered incorrectly	Requires shop service and repair

**This Page Intentionally Left Blank**

***McNeilus***<sup>®</sup>

**888-686-7278**

**[www.StreetSmartParts.com](http://www.StreetSmartParts.com)**