



REVOLUTION™

CONCRETE MIXERS

OPERATOR'S MANUAL

BRIDGEMASTER® MIXER

This manual includes information for:

- Revolution INSIGHT Mixer System™
- Revolution Traditional Controls

Part No. 1679124

Rev. 12/2023

© 2023 Revolution Concrete Mixers

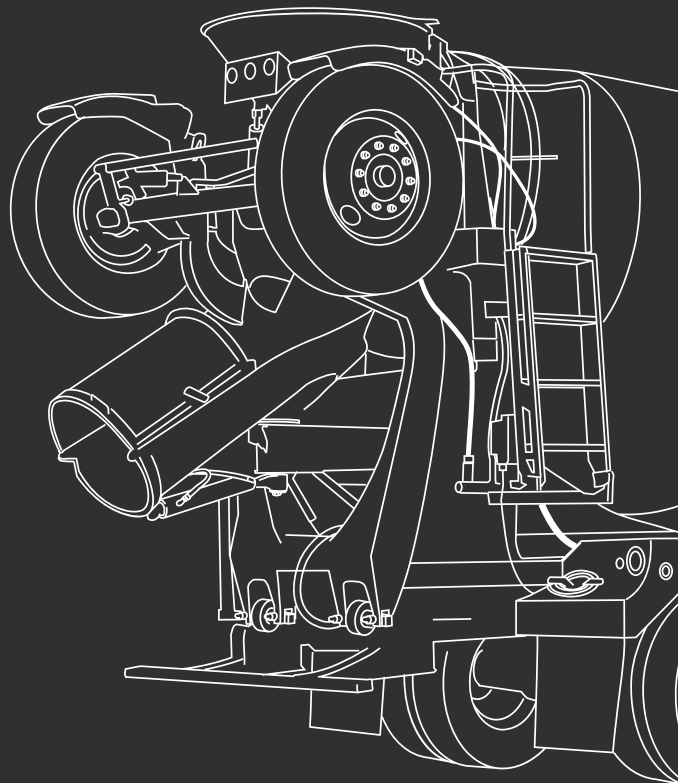

Disclaimer:

This manual must not be used to repair your vehicle. Repair information is available by calling Revolution Customer Service at (888) 209-6497.

The information in this Operator's Manual will be your guide to operation and operator maintenance for this equipment.

All information, illustrations, and specifications in this manual are based on the information available at the time this manual was published. The illustrations used in this manual are intended as representative reference views only. Because of our continuous product improvement policy, we may modify information, illustrations, and/or specifications to explain and/or exemplify a product, service, or maintenance improvement. We reserve the right to make any change at any time without notice. Go to www.streetsmartparts.com for current information.

No part of this publication may be reproduced by any means - graphic, electronic, or mechanical, including photocopying, recording, taping, or information storage and retrieval systems for any use or purpose - without the written permission of Revolution Concrete Mixers

For assistance in ordering OSHA Publications, contact:

U.S. Department of Labor/OSHA

200 Constitution Ave. NW

Room Number N3626

Washington, D.C. 20210

Telephone: 800-321-6742 • www.OSHA.gov

 **WARNING**

Operating, servicing, and maintaining this vehicle or equipment can expose you to chemicals including exhaust, carbon monoxide, phthalates, and lead, which are known to the state of California to cause cancer and birth defects or other reproductive harm. To minimize exposure, avoid breathing exhaust, do not idle the engine except as necessary, service your vehicle or equipment in a well ventilated area and wear gloves or wash hands frequently when servicing. For more information, go to www.p65warnings.ca.gov.

1.0 Identification

1.1 Mixer Identification Plate and TMMB Certification Placard

Revolution Concrete Mixers identification plate (Figure 1, Item 1) is located on the left side of the front pedestal. The identification plate contains the serial number (Figure 1, Item 2) and the rated mix capacity (Figure 1, Item 3) of your mixer system.

The identification plate also contains the drum volume and water tank capacity.

Also located on the left side of the front pedestal is the Truck Mixer Manufacturers Bureau (TMMB) certification placard (Figure 1, Item 4). This decal indicates the certified maximum capacity of the Mixer.

The drum serial number (Figure 1, Item 5) is stamped into the pedestal.

Please fill out the following information and have it ready when calling Revolution Concrete Mixers for parts or product information:

Date of Purchase: _____

Branch: _____

Serial Number of Mixer: _____

Serial Number of Drum: _____

VIN* _____

*Refer to chassis manufacturer literature for location.

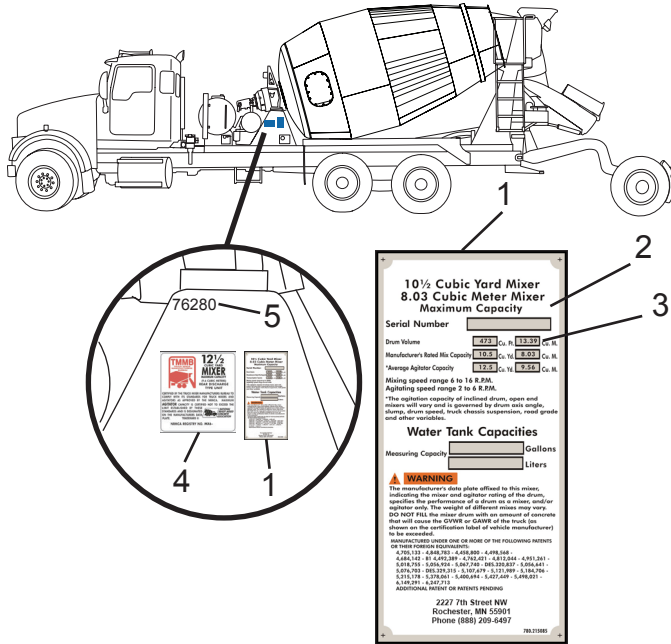

1.1.1 Mixer Serial Number Explanation

The Mixer Serial Number (Figure 2, Item 2) located on the identification plate (Figure 2, Item 1) will be needed when making service inquiries or when ordering parts.

The serial number is a five-digit sequential number, and contains no information such as Mixer build date, etc. This type of information is located on the Complete Vehicle Document decal.

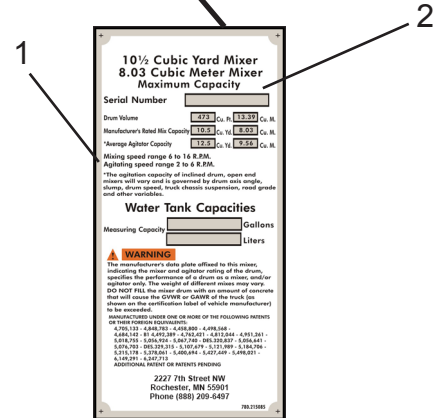
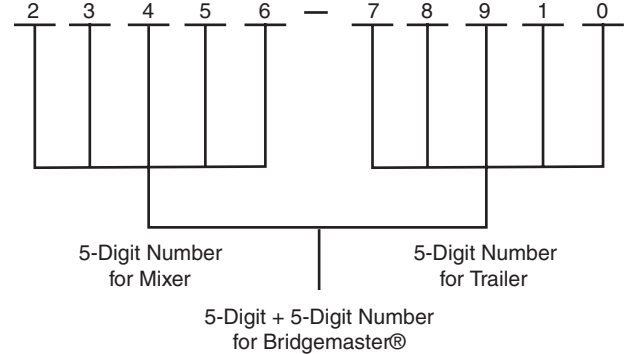

Figure 2

1.2 Complete Vehicle Document Decal

The Complete Vehicle Document decal (Figure 3, Item 1) documents the axle load and tire ratings as the vehicle left the Revolution production line. This decal is located inside the cab, and may be placed on driver's doorjamb, or seat riser.

This decal includes information such as the Maximum rated weight per axle (Item 2), Gross Vehicle Weight (Item 3), Chassis manufacturer (Item 4), Chassis build date (Item 5), Vehicle (chassis) ID number (Item 6), Tire and rim size and tire pressure specifications (Item 7), and the Vehicle system build date (Item 8).

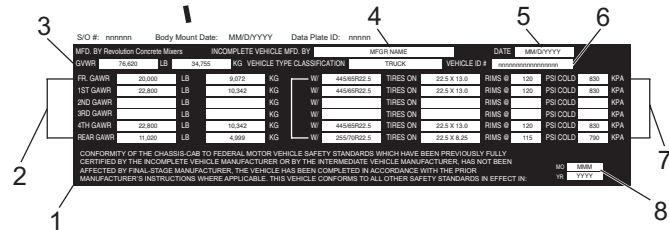
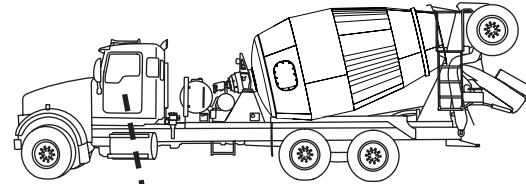

Figure 3

2.0 Purpose of Manual

This Operator's Manual provides operation and operator maintenance instructions for the Bridgemaster® (BM) Mixer manufactured by Revolution Concrete Mixers.

The information in this operator's manual will be your guide to operation and operator maintenance for this equipment.

Keep this manual with the vehicle at all times.

WARNING

The operator of this Mixer must be properly licensed and trained to operate this Mixer. If you are uncertain how to operate this Mixer, inform your supervisor or contact Revolution Customer Service at (855) 202-6491. Failure to comply may result in serious personal injury or death and void the mixer vehicle warranty.

NOTE

This manual is limited to the operation and light maintenance of the Mixer system only. Because the Mixer system may be mounted on various chassis, this manual does not include the operation or maintenance of the chassis. Refer to the chassis manual provided with your Mixer for chassis operation and maintenance information.

3.0 Scope

This manual provides information for use by the equipment operator under the following headings:

1. **Safety.** Includes important safety information.
2. **Operation.** Includes equipment identification Includes control functionality and normal equipment operation.
3. **Preventive Maintenance.** Includes basic preventive maintenance information for the operator.

4.0 Parts and Service

Contact your Revolution Parts and Support to order parts, receive service information, or for other assistance.

To order a replacement manual or safety signs, contact Revolution.

Contact by phone or visit www.revolutionmixers.com.

Phone Number (855) 202-6491

5.0 Corporate Headquarters

Contact Revolution Concrete Mixers directly at our corporate headquarters at the following address, phone number, and website.

Revolution Concrete Mixers
2227 7th Street NW
Rochester, MN 55901

Telephone: (888) 209-6497

Corporate Website: www.revolutionmixers.com

1.0	IMPORTANT SAFETY INFORMATION	1
1.1	Applying the Lockout/Tagout Procedure.....	1
SAFETY		
1.1.1	Removing the Lockout/Tagout Procedure	7
1.1.2	Restoring Equipment to Normal Production Operations	10
1.2	Battery Cable Disconnect.....	10
1.3	Safety Equipment	11
1.4	Reporting Safety Defects	11
2.0	PRODUCT SAFETY INFORMATION	12
2.1	Use Proper Safety Equipment.....	13
3.0	SAFETY INFORMATION.....	14
3.1	Safety	14
3.2	Cab Operation	15
3.3	Outside Operation	17
3.4	Maintenance.....	21
3.5	Hydraulics.....	24
3.6	Electrical	25
3.7	Chute Extensions	26
1.0	EXTERIOR SYSTEMS ARRANGEMENT	29
1.1	Curb Side View.....	29

OPERATION

1.2	Street Side View	30
1.0	BEFORE PLACING THE MIXER INTO SERVICE	31
1.1	INSIGHT System Deactivate Transport Feature	31
1.2	Traditional Controls Deactivate Transport Feature	32
2.0	INSIGHT MIXER SYSTEM INSTRUMENTS AND CONTROLS	33
2.1	Home/Drum Screen Overview	34
2.2	Speed/Direction Sensor Reading Screen Overview	35
2.3	Drum Revolution Counter Screen Overview	36
2.4	Auxiliary Function Icons	37
2.4.1	INSIGHT System Enabled Package	38
2.5	Touch Screen Display Button Overview	41

OPERATION

2.6	Touch Screen Display Status Icons	42
2.7	Cab Control Keypad (Standard)	43
2.8	Cab Control Keypad (Optional)	45
2.9	Optional Joystick for Chute Lock/Unlock, Chute Up/Down Functions	46
2.10	Outside Controls	47
2.10.1	Rear Pendant Control Keypad	48
2.10.2	Cable Drum Control (If Equipped)	51

2.10.3	Manual Chute Lock	52
2.11	Fuse Functions	53
2.12	Manual Drum Operation	55
2.12.1	EP Controls	55
2.12.1.1	Manual Override - CHARGE and DISCHARGE	55
2.12.1.2	Manual Override - Locking for Transit.....	56
3.0	CONTROL FUNCTIONS FOR INSIGHT SYSTEM	57
3.1	Start-Up Function	57
3.2	Rotating the Drum from the Joystick, Optional In-Cab Keypad, or Rear Pendant Keypad	58
3.3	Rotating the Drum with the Wireless Transmitter (If Equipped)	59
3.4	Drum Stop Operation	60
3.5	Load Function (If Equipped - Electronic Drum Controls Only)	62
3.6	Mix Function (If Equipped - Electronic Drum Controls Only).....	63
3.7	Constant Speed Function (If Equipped - Electronic Drum Controls Only).....	64
3.8	Hopper Function.....	66
3.9	Chute Lock Function	67
3.10	Chute Raise/Lower and Swing Functions	68
3.11	Hopper, Chute Lock, and Chute Operation with Wireless Transmitter (If Equipped).....	69
3.12	Work Lighting Functions.....	70

3.13	Bridgemaster Axle Operation	71
3.13.1	Operation Notes for Bridgemaster Axle.....	72
3.13.2	Bridgemaster Axle Service Brake Operation.....	73
3.13.2.1	Normal Service Brake Operation (All Chassis Models)	73
3.13.2.2	Parking Service Brake Operation (Option).....	73
3.13.3	Emergency Manual Bridgemaster Axle Operation	73
3.13.3.1	Lowering the Bridgemaster Axle	73
3.13.3.2	Raising the Bridgemaster Axle.....	77
4.0	TRADITIONAL ELECTRONIC CONTROL SYSTEM INSTRUMENTS AND CONTROLS	80
4.1	EP Drum Control System	80
4.1.1	Maestro Revision E-10.....	80
4.1.2	How to Identify Revision E-10	80
4.2	Electronic Cab Controls - Cab Control Pendant.....	82
4.2.1	Electronic Cab Control Rocker Switch Functions.....	83
4.2.2	Indicator Light and Display Functions	86
4.3	Electronic Cab Controls - Cab Control Box	88
4.3.1	Electronic Cab Control Rocker Switch Functions.....	89
4.3.2	Indicator Light and Display Functions	92
4.4	Electronic Outside Controls.....	94
4.4.1	Electronic Rear Pendant Controls.....	95

4.4.1.1	By-Passing the Rear Pendant.....	96
4.4.2	Manual Chute Lock	98
4.5	Electronic Control Fuse Functions	99
4.6	Fault Display - EP and RE Controls	101
4.6.1	Fault Codes	101
4.7	Drum Control Checkout Procedure	102
4.8	Add Water Function (If Equipped)	102
4.8.1	Manual Water Injection System.....	102
4.8.2	Remote Water Injection System.....	104
5.0	TRADITIONAL CABLE CONTROL SYSTEM INSTRUMENTS AND CONTROLS	104
5.1	Cable Cab Controls	104
5.1.1	Cable Control Rocker Switch Functions.....	105
5.1.2	Indicator Light and Display Functions	108
5.2	Cable Outside Controls	109
5.2.1	Cable Rear Control Pendant	110
5.2.1.1	By-Passing the Rear Pendant.....	112
5.2.2	Cable Rear Drum Control.....	113
5.2.3	Manual Chute Lock	115
5.2.4	Manual Drum Operation	116
5.2.4.1	Manual Override - CHARGE and DISCHARGE	116

5.2.4.2	Manual Override - Locking for Transit.....	117
5.3	Cable Control Fuse Functions.....	118
5.4	Add Water Function (If Equipped).....	120
5.4.1	Manual Water Injection System.....	120
5.4.2	Remote Water Injection System.....	121
6.0	CONTROL FUNCTIONS FOR TRADITIONAL CONTROLS.....	121
6.1	Bridgemaster Axle Operation.....	121
6.1.1	Lowering the Bridgemaster Axle.....	121
6.1.2	Raising the Bridgemaster Axle.....	124
6.1.3	Operation Notes for Bridgemaster Axle.....	127
6.1.4	Bridgemaster Axle Service Brake Operation.....	127
6.1.4.1	Normal Service Brake Operation (All Chassis Models).....	127
6.1.4.2	Parking Service Brake Operation (Option).....	127
6.1.5	Emergency Manual Bridgemaster Axle Operation.....	128
6.1.5.1	Lowering the Bridgemaster Axle.....	128
7.0	OPERATING PROCEDURES.....	132
7.1	Start-Up Procedure.....	132
7.2	Warm-Up Procedure.....	132
7.3	Adjusting the Throttle Speed.....	133
7.3.1	Mack® Engines.....	133

7.3.2	Mack® Engines – Wireless Remote Control	133
7.3.3	Cummins® Engines	134
7.4	Platform Gate Bar Usage (Optional Equipment)	134
7.5	Loading the Mixer Drum	134
7.5.1	Working Around Concrete Pumps	135
7.6	Traveling to the Job Site	136
7.7	Positioning the Truck for Discharge	137
7.8	Chute Operation	138
7.8.1	Unfold the Fold-Over Chute	138
7.8.2	Using Chute Extensions	139
7.8.3	Position the Discharge Chute Assembly	140
7.9	Discharging the Load	141
7.10	Wash Down the Mixer Before Leaving the Job Site	142
7.11	Returning from the Job Site	145
7.12	End-of-Day Cleaning Procedure	146
7.12.1	End-of-Day Checks	146
8.0	WATER TANKS	147
8.1	Water Tank Safety	147
8.2	Water Tank Operation	148

Table of Contents



8.2.1	Introduction.....	148
8.2.2	Daily Operation.....	148
8.2.2.1	Tank Integrity.....	148
8.2.2.2	Pressure Regulator Valve	148
8.2.2.3	Pressure Relief Valve.....	149
8.2.3	Daily Operation.....	149
8.2.4	Vehicle Handling Characteristics.....	149
8.3	Water Tank Safety Sign Identification.....	150
8.4	Water Tank Mounting Positions	151
8.5	Standard Water Tank.....	151
8.5.1	Single Sight Gauge	151
8.6	Split Water Tank (Optional).....	152
8.6.1	Dual Sight Gauges	152
9.0	WATER SYSTEM - PRESSURIZED	153
9.1	Depressurizing the Water Tank	153
9.2	Pressurizing the Water Tank.....	154
9.3	Draining the Water System.....	155
9.4	Filling the Main Tank.....	158
9.5	Filling the Chemical Tank (Split Tank Option).....	158
10.0	WATER SYSTEM - PUMP.....	160

10.1	Pump Operation	160
10.2	Filling the Water Tank	162
10.3	Filling the Chemical Tank - Steel or Aluminum Tanks (Split Tank Option)	163
10.4	Draining the Water System.....	164
11.0	WATER SYSTEM FUNCTIONS (OPTIONAL EQUIPMENT).....	168
11.1	Washout Hoses	168
11.1.1	Upper Washout Hose	168
11.1.2	Front Washout Hose.....	168
11.1.3	Valve Drain	168
11.2	Auto Washout System for INSIGHT Mixer System.....	170
11.3	Manual Washout System.....	172
11.4	Spray Bar.....	173
11.5	Water Meter Function	174
11.5.1	Precision Water Meters	174
11.5.2	BR Industries (BM-25) Water Meter	175
11.5.3	GPI® Water Meters.....	176
11.5.4	UFM Water Meters	178
12.0	OPTIONAL EQUIPMENT	178
12.1	Hydraulic Fold-over Chute.....	178
12.2	Chute Assist	180

12.3	Hydraulic Chute Swing	182
12.4	Discharge Chute Vibrator Valve	183
12.5	Chute Blockers	183
12.6	Fold-over Stop	183
12.7	Flip-Up Charge Hopper	184
12.8	Swing Away Throat (SAT) Charge Hopper	185
12.9	Right Hand Turn Audible Warning System	185
12.10	Lateral Protection Device	185
12.11	Preco for INSIGHT Mixer System	187
12.12	Concrete Slump Meter	189
12.12.1	Setting the Mechanical Concrete Slump Meter	190
12.12.2	Setting the Digital Concrete Slump Meter for INSIGHT System Only	191
12.12.2.1	Loading a Slump Calibration Profile	193
12.13	Central Lubrication Systems	194
12.14	Wireless Transmitter	196
12.14.1	Wireless Remote Control (Cab Console Version)	196
12.14.1.1	Control Buttons and Switches For INSIGHT System	196
12.14.1.2	LED Indicators for INSIGHT System	199
12.14.1.3	Control Buttons and Switches For Traditional Controls	200
12.14.1.4	LED Indicators for Traditional Controls	203

12.14.2	Cleaning the Transmitter	204
12.14.3	Wireless Remote Control (Optional) Troubleshooting	204
12.14.3.1	Diagnostic Codes – Transmitter	204
12.14.4	Receiver Locations	208
12.14.4.1	LED Indicators	208
12.14.4.2	Normal Operation	209
12.14.4.3	Fault Codes	210
13.0	CHASSIS OPTIONS	214
13.1	Pusher Axle	214
13.1.1	Raising or Lowering Pusher Axle for INSIGHT System Only	215
13.1.2	Lowering Pusher Axle for Traditional Controls Only	216
1.0	PREVENTIVE MAINTENANCE	217
1.1	DOT Pre-Trip	217
2.0	PREVENTIVE MAINTENANCE INTERVALS	217
PREVENTIVE MAINTENANCE		
3.0	PREVENTIVE MAINTENANCE DAILY CHECKS	226
3.1	Hydraulic System	226
3.1.1	Hydraulic Oil Level	226
3.1.2	Hydraulic System and Components	227
3.2	Electrical System	227

3.2.1	Lighting System.....	227
3.2.2	Warning Alarm System.....	227
3.3	Pneumatic System	228
3.3.1	Coalescing Filter.....	228
3.4	Mechanical System	228
3.4.1	Mixer Components and Pedestals	228
3.4.2	Water Tanks.....	229
PREVENTIVE MAINTENANCE		
3.4.3	Chute Extensions	230
3.4.4	Chute Assist	231
3.5	Standard (Steel) Drum	232
3.5.1	Standard (Steel) Drum Inspection.....	232
3.5.2	Concrete Removal.....	234
3.6	Operation.....	234
3.6.1	Mixer Controls	234
3.7	Safety Decals	235
3.8	Safety Decal and Placard Locations	238
3.8.1	Passenger Side Views	238
3.8.2	Driver Side Views.....	240
4.0	OPTIONAL EQUIPMENT MAINTENANCE	243

4.1	Spray Bar Strainer	243
4.2	GPI® Water Meters	244
4.2.1	Battery Replacement.....	244
4.3	Optional Pusher Axle Maintenance	245
5.0	LUBRICATION.....	245
5.1	Daily Lubrication	245
5.2	Daily Lubrication – Remote Lubrication System (If Equipped)	245
5.3	Daily Lubrication – Central Lubrication Systems.....	248
5.4	Weekly Lubrication	250
	INDEX.....	253

INDEX

This Page Intentionally Left Blank

1.0 Important Safety Information

WARNING

READ AND UNDERSTAND THIS ENTIRE MANUAL BEFORE OPERATING, REPAIRING, OR ADJUSTING YOUR REVOLUTION EQUIPMENT.

THOSE WHO USE AND MAINTAIN THIS EQUIPMENT MUST BE THOROUGHLY TRAINED AND FAMILIAR WITH THE PRODUCT.

IF INCORRECTLY USED OR MAINTAINED, THIS EQUIPMENT CAN CAUSE SEVERE INJURY.

Always keep this manual in a location where it is readily available for persons who operate or maintain the product. Additional copies of this manual are available from Revolution Concrete Mixers. Please contact Revolution Concrete Mixers if you require additional manuals or if you have any questions about the information in this manual, this product, or safe operating procedures.

THESE SAFETY PROCEDURES ARE FOR YOUR OWN PROTECTION.

Do not operate this equipment until you have read its contents thoroughly. Read and understand the NRMCA manual that is placed in the vehicle's cab. Please contact Revolution Concrete Mixers if you require assistance.

Should operators of this equipment have a reading or learning disability, dyslexia, or other such condition, they must be assigned a mentor/trainer to read and explain to them the entire contents of this manual as well as the safety guidelines, danger, caution, and warning safety signs on this unit. Such individuals should not be allowed to operate this equipment until they thoroughly understand all of these materials. Failure to do so can result in serious injury or death.

Safety and safe working procedures must be followed at all times.

Perform your company's Lockout/Tagout procedure. If your company does not have a Lockout/Tagout procedure, follow OSHA 1910.147 and 1910.146 Confined Space as appropriate.

WARNING

Anytime you are working on this equipment or its related systems, you must do the following:

- 1. Inform the truck driver that the equipment is going to be repaired and locked out and that he must not attempt to start the truck.**
- 2. Follow OSHA confined space regulation 1910.146 and Lockout/Tagout 1910.147 Remove the keys from the ignition. Read, understand, and follow the safety guidelines, dangers, and warnings listed below and contained in this manual to promote reliable operation and prevent serious personal injury.**

1.1 Applying the Lockout/Tagout Procedure

1. Before any personnel can perform mixer drum service or maintenance, the employee or supervisor must inform the driver that his/her vehicle/mixer system is going to be “Locked Out,” and that he/she must not attempt to restart it until notified that it is safe to do so.
2. Position the truck on a firm, level surface. Place the transmission in PARK or NEUTRAL, and engage the park brake. Allow the engine to run at idle. (Refer to the Operator’s Manual supplied by the chassis supplier for all parking procedures.)
3. Place wheel chocks or blocks in front of and behind the truck’s front wheels.
4. Turn the PRV knob (Figure 1, Item 1) all the way counterclockwise to minimize the pressure applied to the Bridgemaster axle when the drum is empty. Pressure will be displayed on the gauge (Figure 1 Item 2).

WARNING

Turn the PRV (Pressure Regulating Valve) fully counterclockwise to minimize the pressure applied to the Bridgemaster® trailer when the drum is empty. Failure to comply may result in serious personal injury or death.

NOTE

The Bridgemaster® pressure gauge may be located near the Bridgemaster valve, or in the truck cab, depending on the Mixer configuration.

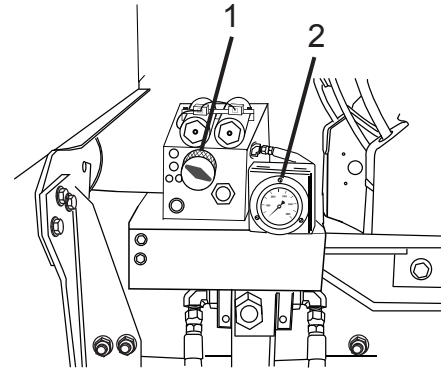

Figure 1

WARNING

Always lower the Bridgemaster® trailer completely to the ground before performing service. If lowering the Bridgemaster® trailer is not possible, chain the trailer assembly to the rear pedestal using an OSHA-approved Grade 80 chain, rated at 10,000 pounds. Failure to comply may result in serious personal injury or death.

5. If possible, lower the Bridgemaster axle completely to the ground.

If the Bridgemaster axle cannot be lowered to the ground, securely chain the axle to the rear pedestal in the full up position.

If it is necessary to lower the Bridgemaster axle part way down, always support the axle using stands capable of supporting the full weight of the axle.

 **CAUTION**

Make sure the fold-over chute is folded and the discharge chute is centered and lowered before raising or lowering the Bridgemaster® trailer. Failure to comply may cause damage to property or equipment.

- a. Make sure the fold-over chute is folded, and the discharge chute is centered and lowered. You can check its status on the on-screen display AND through visual observation.

 **WARNING**

Make sure the area behind the truck is clear of people or obstructions before lowering the Bridgemaster® trailer. Failure to comply may result in serious personal injury or death.

6. Use the buttons or rocker switches on the in-cab keypad to lower the Bridgemaster Axle.
7. Position the drum hatch (Figure 2, Item 1) so the hatch is on the driver's side to perform service and maintenance.
 - Control the drum speed by manipulating the drum control on the cab keypad or the lever in the cab, or the control lever at the rear of the truck.
8. Make sure that the mixer drum warning signs (Figure 2, Item 2) are clean, readable, and properly positioned. Replace any damaged or unreadable signs immediately.

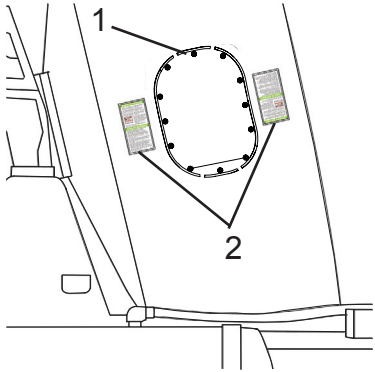

Figure 2

NOTE

Shutting off the truck engine will stop mixer drum rotation.

9. Engage the park brake and stop the chassis engine. (Refer to the Operator Manual supplied by the chassis supplier for all shut-down procedures.)
10. Before entering the mixer drum or performing service, the service/maintenance person must:
 - a. Shut off the truck engine.
 - b. Carry all ignition keys in his/her pocket.

- c. Tag steering wheel using a nonreusable fastener.
11. Roll up all cab windows and lock all doors.
12. Place magnetic “DANGER” signs (Figure 3, Item 1) on both doors: “Man working on drum. Do not start Mixer or rotate drum. Serious personal injury or death can occur.”

NOTE: If the Mixer is equipped with INSIGHT System, proceed to Step 17. For Mixers with Traditional Controls, continue with the following steps.

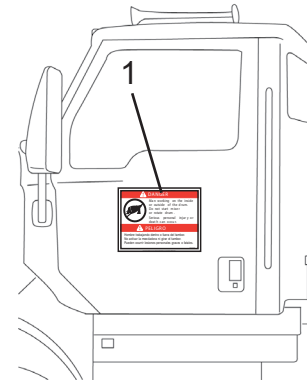

Figure 3

13. **For Traditional Controls with RE (Remote Electric Controls) Only:** Locate and disconnect the main electrical connector (Figure 4, Item 1) from the charge/discharge coils. Move the connector away from its mating connector. Proceed to Step 17.

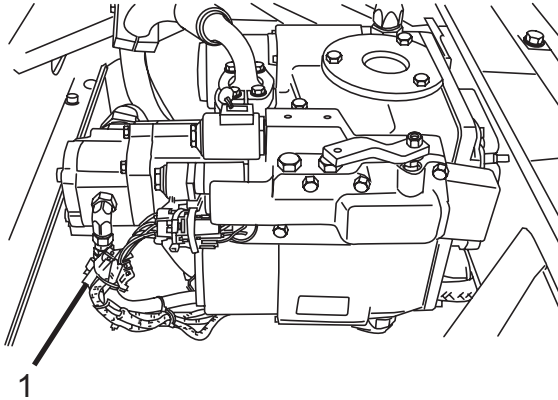

Figure 4

RE (Remote Electric) Controls

14. **For Traditional Controls with EP (Electric Proportional Controls) Only:** Locate and disconnect the main electrical connector (Figure 5, Item 1) from the charge/discharge coils. Move the connector away from its mating connector.

15. Locate and remove the charge/discharge manual override buttons (Figure 5, Items 2 and 3).

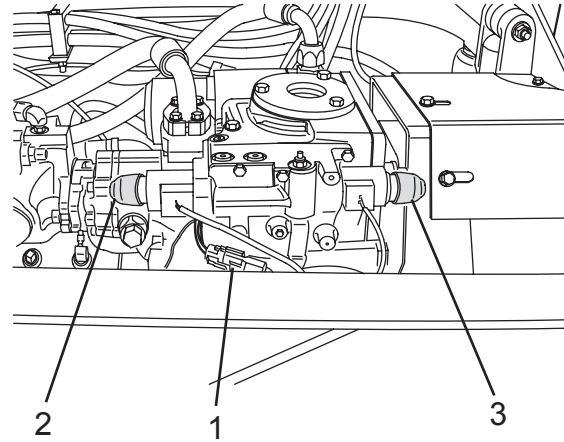

Figure 5

EP (Electric Proportional) Controls

16. Remove the pins (Figure 6, Item 1) from the override caps (Figure 6, Item 2), and replace the caps. Place the pins in your pocket with the truck keys.

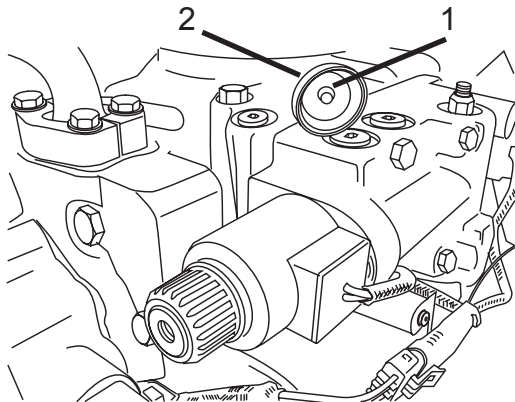

Figure 6

EP (Electric Proportional) Controls

WARNING

If performing service in or on the drum, the dual turnbuckle wedge assembly (and additional blocking as needed) must be used to prevent drum movement. Failure to comply may result in serious personal injury or death.

CAUTION

Concrete build-up and removal of that concrete with pounding or the use of hydraulic tools might cause the drum to slip over the turnbuckle wedge. To help prevent this, additional blocking of the drum may be required. Failure to comply may cause damage to property or equipment.

17. Place the dual turnbuckle wedge assembly base (Figure 7, Item 1) on the rear pedestal. Make sure the wedge assembly base has a flat, clean surface. Extend the turnbuckles (Figure 7, Item 2) so the wedges are firmly in place between the drum roller track and rollers. Evenly snug up the turnbuckles one turn or more as needed to prevent possible drum rotation.
18. Tighten the turnbuckle jam nuts (Figure 7, Item 3) to secure the wedges in place.
19. Place operating equipment at its lowest potential energy position to prevent free fall.
20. Install blocking devices to prevent any raised device from falling.

21. If maintenance is needed on the hydraulic or pneumatic systems, after blocking devices are installed, relieve stored hydraulic or pneumatic pressure.

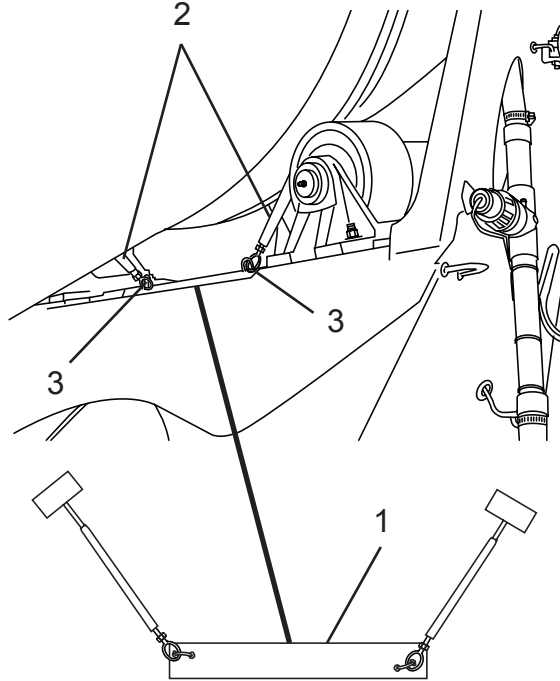

Figure 7

1.1.1 Removing the Lockout/Tagout Procedure

1. Loosen the turnbuckle jam nuts (Figure 8, Item 1).
2. Rotate the turnbuckles (Figure 8, Item 2) to retract the wedges from the drum roller track and rollers.
3. Remove the dual turnbuckle wedge assembly (Figure 8, Item 3) and any blocking from the rear pedestal.

NOTE: If the Mixer is equipped with INSIGHT System, proceed to Step 8. For Mixers with Traditional Controls, continue with the following steps.

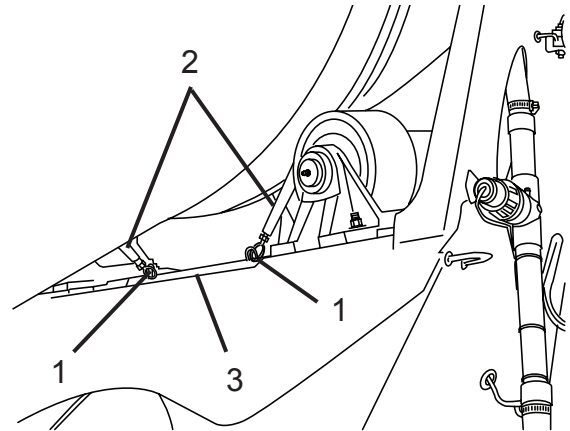

Figure 8

Safety

4. **For Traditional Controls with RE (Remote Electric Controls) Only:** Connect the main electrical connector (Figure 9, Item 1) to the charge/discharge coils. Proceed to Step 8.

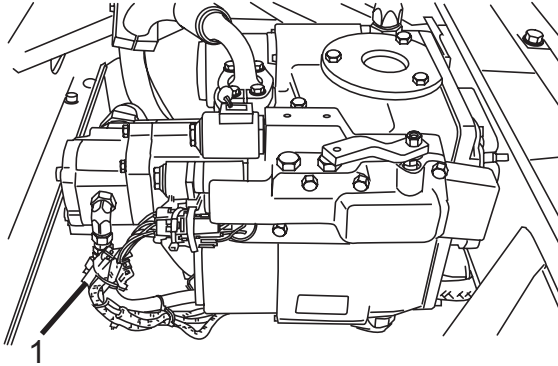

Figure 9

RE (Remote Electric) Controls

5. **For Traditional Controls with EP (Electric Proportional Controls) Only:** Install the pins (Figure 10, Item 1) in the override caps (Figure 10, Item 2).

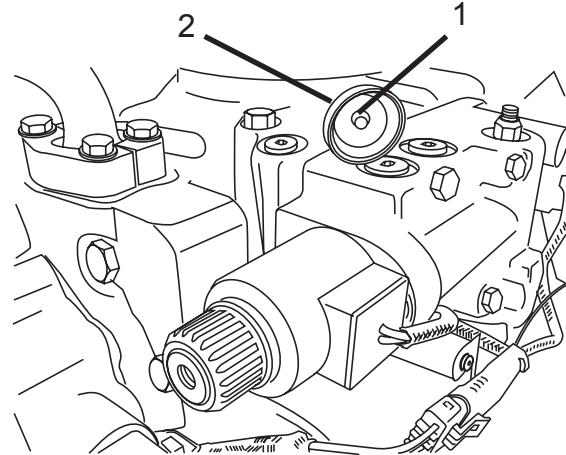

Figure 10

EP (Electric Proportional) Controls

6. Connect the main electrical connector (Figure 11, Item 1) to the charge/discharge coils.
7. Install the charge/discharge manual override caps (Figure 11, Items 2 and 3).

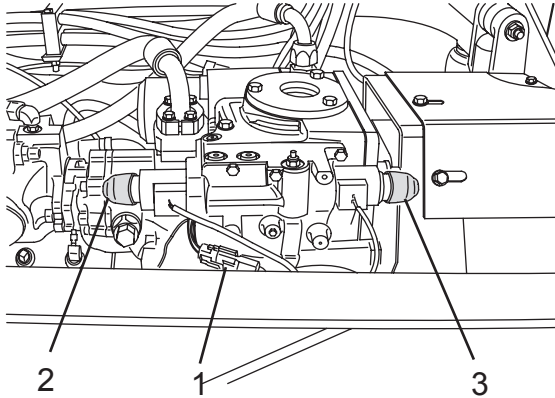

Figure 11

EP (Electric Proportional) Controls

8. Remove magnetic “DANGER” signs (Figure 12, Item 1) from both doors.
9. Unlock cab doors.
10. Remove and discard the steering wheel fastener.

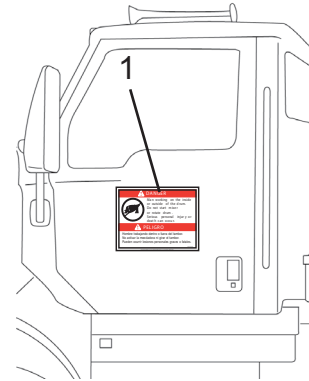

Figure 12

11. Remove all tools and other foreign objects from the area.
12. Check to make sure all mixer components (chutes, ladders, hoses, etc.) are properly stowed.
13. Inspect the area around the mixer system to make sure all people are clear before starting the Mixer.
14. Remove the wheel chocks or blocks from the front wheels before moving the truck.

1.1.2 Restoring Equipment to Normal Production Operations

1. After the servicing and/or maintenance is complete and the vehicle is ready for normal operations, check the area around the vehicle to ensure that no one is exposed.
2. After all tools have been removed from the vehicle, guards have been reinstalled and employees are in the clear, the employee who applied the LOCKOUT/TAGOUT device(s) will remove the device(s).
3. Notify all affected employees that the vehicle is being put in operation. Operate the energy-isolating devices to restore energy to the vehicle.

1.2 Battery Cable Disconnect

If the Mixer is not equipped with a battery disconnect switch, disconnect the negative (black) battery cable first, then disconnect the positive (red) cable.



WARNING

For trucks without a battery disconnect switch, to prevent accidental vehicle start-up, which could cause death or serious injury, disconnect battery cables (negative cable first) before proceeding.

Disconnect negative (-) battery cable first. If positive (+) cable should contact ground with negative (-) cable connected, the resulting sparks can cause a battery explosion, which could result in death or serious injury.

1.3 Safety Equipment

Some Revolution mixer vehicles come equipped with a five pound Fire Extinguisher, which has a rating of B:C, and a Reflective Warning Triangle Kit containing three triangles.

The fire extinguisher may already be mounted to the body, otherwise it is temporarily placed into the cab of your truck along with the reflective triangle kit.

If you are supplying your own fire extinguisher, it must comply with DOT FMCSA regulation 173.309 and 393.95 for rating and placement on the vehicle.

You are responsible for permanent mounting of this equipment. The fire extinguisher is required to be securely mounted to prevent sliding, rolling, or vertical movement. The mounting location of the reflective triangles is at your discretion.

1.4 Reporting Safety Defects

If you believe that your vehicle has a defect which could cause a crash or could cause injury or death, you should immediately inform the National Highway Traffic Safety Administration (NHTSA) in addition to notifying Revolution Concrete Mixers and the chassis manufacturer.

If NHTSA receives similar complaints, it may open an investigation, and if it finds that a safety defect exists in a group of vehicles, it may order a recall and remedy campaign. However, NHTSA cannot become involved in individual problems between you, your dealer, Revolution Concrete Mixers, or the chassis manufacturer.

To contact NHTSA, you may call the Vehicle Safety Hotline toll-free at 1-888-327-4236 (TTY: 1-800-424-9153); go to <http://www.safercar.gov>; or write to: Administrator, NHTSA, 400 Seventh Street, SW., Washington, DC 20590. You can also obtain other information about motor vehicle safety from <http://www.safercar.gov>.

2.0 Product Safety Information

Safety notices are one of the primary ways to call your attention to potential hazards.



THIS SAFETY SYMBOL INDICATES IMPORTANT SAFETY MESSAGES IN THIS MANUAL.

WHEN YOU SEE THIS SYMBOL, CAREFULLY READ THE MESSAGE THAT FOLLOWS.

BE ALERT TO THE POSSIBILITY OF PERSONAL INJURY OR DEATH.

The following safety notices are used throughout this manual.

DANGER

Danger indicates an imminently hazardous situation which, if not avoided, will result in death or serious injury. Danger is used in the most extreme situations.

WARNING

Warning indicates a potentially hazardous situation which, if not avoided, could result in serious injury or death.

CAUTION

Caution indicates a situation that might result in property damage.

SAFETY NOTICE

OPERATOR'S INSTRUCTION

The signal words of DANGER, WARNING, and CAUTION have specific meanings to alert you to the relative level of hazard.

Take the safety warnings seriously. If you do not understand them or have questions about them, call Revolution Concrete Mixers.

2.1 Use Proper Safety Equipment

Always wear proper safety equipment/clothing while operating the Mixer.

Proper safety equipment includes:

- Hard Hat
- Safety Glasses or Goggles
- Snug-Fitting, Full-Covering Clothes
- Shirt with Tight-Fitting Long Sleeves (always keep shirt tails tucked in)
- Long Pants without Cuffs (Cuffs can be tripped over. Cuffs may also catch concrete)
- Steel-Toed Shoes or Boots
- Rubber Boots (if standing in concrete is required)
- Lime-Resistant Gloves
- Rubber Gloves (during clean-out)
- Hearing Protection
- Breathing Mask (if working in an area where cement dust is present)
- Breathing Apparatus and Ventilation Fan (if working in a Confined Space - see OSHA 1910.146)

Follow these guidelines to reduce risks of injury:

- Avoid wearing clothing that has long strings, fringes, or ties that can become caught in equipment
- Never wear jewelry (rings, necklaces, bracelets, wrist watches, etc.). These can become snagged on equipment or, if they come in contact with electrical circuits, can present a shock or burn hazard.
- Tie up long hair to prevent it from becoming caught in moving parts
- In cold weather, avoid wearing loose-fitting clothing. It is better to wear layers of clothing under a pair of snug-coveralls than a large, loose-fitting jacket or parka
- Keep work clothing clean and in good repair
- Keep the soles of your work boots clean and in good condition for traction when climbing on and off the vehicle/mixer system

3.0 Safety Information

Read, understand, and follow the safety guidelines and heed dangers and warnings listed below and contained in this manual as well as on the Mixer itself to promote reliable operation and prevent serious personal injury.

Contact Revolution Concrete Mixers if you require assistance or have questions.

3.1 Safety

WARNING

Safety decals must be replaced anytime they are damaged, missing, or cannot be read clearly. Failure to have proper decals in place can result in serious injury or death. If you require safety decals, please contact Revolution Concrete Mixers at (855) 202-6491.

WARNING

The mixer vehicle must not be modified in any way without authorization from Revolution Concrete Mixers. Modifications may not comply with safety standards, including ANSI safety standards. Failure to comply may result in serious personal injury or death.

WARNING

Wear Personal Protective Equipment (PPE) such as hard hats, hearing protection, steel toed boots, and snug fitting sturdy long-sleeve shirt and long pants when operating or maintaining the vehicle. Reflective clothing is recommended for drivers and employees while operating the vehicle during hours of darkness. Failure to comply may result in serious personal injury or death.

WARNING

Operating, servicing, and maintaining this vehicle or equipment can expose you to chemicals including exhaust, carbon monoxide, phthalates, and lead, which are known to the state of California to cause cancer and birth defects or other reproductive harm. To minimize exposure, avoid breathing exhaust, do not idle the engine except as necessary, service your vehicle or equipment in a well ventilated area and wear gloves or wash hands frequently when servicing. For more information, go to www.p65warnings.ca.gov.

 **CAUTION**

Fire Hazard. If vehicle is equipped with a battery disconnect switch, it must be turned off anytime the equipment is parked overnight, in a shop, or out of service for any extended period of time. Failure to comply may cause damage to property or equipment.

3.2 Cab Operation

 **DANGER**

If the mixer comes into contact or close proximity with a powerline, or there is any arcing, stay in the truck cab and keep away from metal parts of the unit. Do not let anyone come close to the truck. Do not attempt to jump clear of the truck. Stay in the cab. The power must be disconnected by the power company before you can safely leave the cab.

Minimum clearance from power lines:
50,000 Volts or Less 4 Feet (1.2 Meters)
50,000+ Volts 10 Feet (3.0 Meters)
345,000-750,000 Volts 16 Feet (4.9 Meters)

Know the clearance of overhead obstructions. Never drive the mixer under any overhead obstruction without knowing the clearance height. If unit has a flip-up hopper, be sure hopper is in the lowered position. Failure to do so will result in damage to the mixer body or truck, and may result in serious personal injury or death.

WARNING

Crush Hazard. Never walk or stand behind vehicle while it is backing up. Failure to comply may result in serious personal injury or death.

WARNING

Crush Hazard. The operator and anyone working in the area of the Mixer should understand the meaning of all audible alarms and warning lights. Failure to comply may result in serious personal injury or death.

WARNING

Crush Hazard. Make sure the area behind the truck is clear of people or obstructions before raising or lowering the Bridgemaster® trailer. The alarm in both the cab and at the rear of the mixer sounds when the trailer is traveling up or down. Keep clear of the area behind the truck and of the trailer pinch points while the trailer is in motion. Failure to comply may result in serious personal injury or death.

WARNING

Crush Hazard. Remain attentive at all times when operating the controls. Be sure everyone is clear of the area around the truck before operating the Mixer. Thoroughly understand the controls before operating the vehicle. Failure to comply may result in serious personal injury or death.

WARNING

Crash Hazard. No passenger is allowed in the cab unless a manufacturer's approved passenger seat and seat belt are provided. Failure to comply may result in serious personal injury or death.

WARNING

Roll-over Hazard. The Mixer vehicle and the chassis must not be overloaded. Do not exceed the manufacturer's gross vehicle weight rating. Gross weights must meet federal, state, and local laws. Failure to comply may result in serious personal injury or death.

WARNING

Roll-Over Hazard. Use slower speeds when going around curves or corners. You are carrying a high center of gravity load. Failure to comply may result in serious personal injury or death.

 WARNING

Burst Hazard. Never drive the truck with the water tank pressurized. Failure to comply may result in serious personal injury or death.

 WARNING

At the job site, use the lowest transmission gear and proceed at low speed, 5 mph (8.3 km/h) maximum, to the discharge area. Failure to comply may result in serious personal injury or death.

3.3 Outside Operation

 WARNING

Air chute lock is intended for use only on the job site. The manual chute lock should always be engaged during transport. Excessive wear or injury may result due to improper usage. Failure to comply may result in serious personal injury or death.

 WARNING

Burst Hazard. Never pressurize water tank in excess of 55 psi (380 kPa). If pressure exceeds 55 psi (380 kPa), depressurize the water tank immediately and adjust or replace the air regulator valve. Failure to comply may result in serious personal injury or death.

 WARNING

Burst Hazard. Never pressurize an empty water tank. Failure to comply may result in serious personal injury or death.

WARNING

IMPORTANT ALUMINUM AND STEEL WATER TANK INFORMATION.

1. Inspect water tank on a daily basis for any damage including, but not limited to, dents, gouges in metal, or leaks.
2. Do not weld on or repair water tank. Instead, replace water tank with a new OEM water tank.
3. Never pressure test an empty water tank. Only pressure test a full water tank.
4. Never remove pressure regulator or pressure safety valve from tank.
 - If regulator or safety valve is defective, it must be replaced before Mixer is put into service.
5. Do not pressurized water tank beyond its working pressure.
 - If pressure exceeds the working pressure, immediately depressurize water tank and replace pressure regulator and pressure safety valve.
6. Never drive the truck with the water tank pressurized.

- Depressurize water tank prior to transit to or from job site.
- Water tank should be pressurized only when being used.

7. Never modify water tank in any way.
8. Immediately replace safety decals with OEM decals if decals are missing or difficult to read.
9. Refer to the Revolution Operator's Manual or contact Revolution at (888) 209-6497 if you have questions or require assistance.

WARNING

NEVER drink the water from a water tank. The water tank may contain residue from chemicals used to modify concrete properties. Failure to comply may result in serious personal injury or death.

 WARNING

Fall Hazard. Use the three-point contact method (either two hands and one foot, or two feet and one hand on the ladder at all times) when climbing the ladder. Always face the ladder when climbing up or down. Failure to comply may result in serious personal injury or death.

 WARNING

Fall Hazard. Do not climb on ladders or ride on platforms (if equipped with either) while the truck is in motion or when ladders or platforms are wet and slippery. Failure to comply may result in serious personal injury or death.

 WARNING

Crush Hazard. Never walk or stand behind vehicle while it is backing up. Failure to comply may result in serious personal injury or death.

 WARNING

Crush Hazard. Do not wear watches, rings, and jewelry while operating or working with electrical and mechanical equipment. These items can be hazardous and can cause serious and painful injuries if they come into contact with electrical wires, moving parts, or hydraulic equipment. Failure to comply may result in serious personal injury or death.

 WARNING

Pinch Hazard. Always keep hands and feet clear of the Mixer drum, revolving parts, and moving parts at all times. Failure to comply may result in serious personal injury or death.

 WARNING

Roll-over Hazard. Axle load pressures should match payload to be transported. Mixer must not carry more payload than what vehicle is rated for.

 WARNING

Extended Tag Axle Hazard. Recheck the Hydraulic Bridgemaster® Down Pressure against the load to be transported. If there is too much pressure the truck driving tandem could be affected by loss of traction. Always set pressure to the lowest setting when the Mixer is unloaded. Do not run with the Bridgemaster® trailer down when the Mixer is not loaded. Failure to comply may result in serious personal injury or death.

 WARNING

Crush Hazard. All personnel must stand clear of the chutes during raising and lowering, and when chutes are loaded with concrete. Position chutes while they are not loaded. A loaded chute falling on a person may cause serious injury. All chutes must be handled with great care to avoid injury. Do not stand on chutes. Failure to comply may result in serious personal injury or death.

 WARNING

Crush Hazard. Do not let persons, other than the driver, handle the chutes, unfold the foldover, and/or remove extension, or stow and secure the extensions for transit. Keep hands away from chute hardware where the chutes connect. Never stand in the path of the chute as it is being unfolded or while in use. Failure to comply may result in serious personal injury or death.

 WARNING

Wear Personal Protective Equipment (PPE) such as hard hats, hearing protection, eye protection, gloves, steel toed boots, and snug fitting sturdy long-sleeve shirt and long pants when operating or maintaining the vehicle. Reflective clothing is recommended for drivers and employees while operating the vehicle during hours of darkness. Failure to comply may result in serious personal injury or death.

 **CAUTION**

Fall Hazard. Do not use the water tank as a step. Failure to comply may cause damage to property or equipment.

 **CAUTION**

Liquid nitrogen should be applied directly to the concrete mix. If liquid nitrogen comes in direct contact with the drum, it could lead to early drum component failure. Failure to comply may cause damage to property or equipment.

3.4 Maintenance

SAFETY NOTICE

Perform your company's Lockout/Tagout procedure. If your company does not have a Lockout/Tagout procedure, follow OSHA 1910.147 and 1910.146 Confined Space as appropriate.

 **DANGER**

Crush Hazard. LOCKOUT/TAGOUT procedures must be followed when working on this equipment. Failure to comply will result in serious personal injury or death.

 **DANGER**

Crush Hazard. Do not attempt to use extraneous sources of power or extraneous machines to overcome a malfunctioning system. Contact Revolution Concrete Mixers if you are unsure how to proceed. Do not override with overhead cranes, forklifts, jacks, etc., or jury-rig systems or equipment that may be malfunctioning. Failure to comply will result in serious personal injury or death.

⚠ WARNING

Crush Hazard. Always lower the Bridgemaster® trailer completely to the ground before performing service. If lowering the Bridgemaster® trailer is not possible, chain the trailer assembly to the rear pedestal using an OSHA-approved Grade 80 chain, rated at 10,000 pounds. Failure to comply may result in serious personal injury or death.

⚠ WARNING

The mixer vehicle must not be modified in any way without authorization from Revolution Concrete Mixers at (888) 209-6497. Modifications may not comply with safety standards, including SAE J2967 Ready Mixed Concrete Truck Recommended Practice. Failure to comply may result in serious personal injury or death.

⚠ WARNING

Daily inspections should be performed on the mixer vehicle. This includes

- proper operation of the controls
- hydraulic system
- electrical system
- pneumatic system
- structural components

Correct all identified deficiencies BEFORE operating the mixer vehicle. Failure to correct deficiencies may cause damage to equipment. Failure to comply may result in serious personal injury or death.

⚠ WARNING

Main, fold-over, and extension chutes must be inspected on a daily basis for damage, excessive wear, proper hardware fit, twist, and overall condition to determine that they are safe to use. Unsafe chutes must be replaced with new chutes. Failure to comply may result in serious personal injury or death.

 **WARNING**

Always check body/vehicle lights on the chassis or on the vehicle body. (Note: Not all models have indicator lights.) Replace bulbs or lights when required. Failure to inspect lights may lead to more serious conditions. Failure to comply may result in serious personal injury or death.

 **WARNING**

Exceeding axle gross weight will result in premature brake wear and reduced brake performance. Inspect and adjust chassis brake as per the chassis manufacturer's recommendations. Failure to comply may result in serious personal injury or death.

 **WARNING**

Never enter under the chassis unless the Mixer is in the Lockout mode. Remember to follow the Lockout procedures when working under the truck. Failure to comply may result in serious personal injury or death.

 **WARNING**

When working on the Mixer, the wheels must be chocked, the parking brake on, LOCKOUT procedure in effect, and the keys out of the truck's ignition. Failure to comply may result in serious personal injury or death.

 **WARNING**

Burst Hazard. Do not repair or weld on steel or aluminum water tanks. Inspect the water tank for rust and corrosion every 30 days. Inspect the water tank under the straps, on the exterior and interior by removing the flopper. If any rust or corrosion is found, replace the water tank with an OEM water tank from Revolution. Contact Revolution Concrete Mixers with questions. Failure to comply may result in serious personal injury or death.

3.5 Hydraulics

WARNING

High Pressure Fluid Hazard. Hydraulic hoses and tubes must be inspected on a daily basis. If you find hoses with damage, they must be replaced before the vehicle is returned to service. Never operate the hydraulic system if a leak is present. Failure to comply may result in serious personal injury or death.

WARNING

Burn Hazard. Hydraulic systems are hot. **DO NOT TOUCH!** Serious personal injury or death may result from hot oil. Failure to comply may result in serious personal injury or death.

WARNING

Crush Hazard. The hydraulic cylinders can be holding a function in a certain position when the engine is OFF. Block and secure all applicable devices and functions before beginning work or operation. Failure to comply may result in serious personal injury or death.

WARNING

High Pressure Fluid Hazard. All hydraulic pressure must be relieved from the hydraulic system prior to removing any components from the system. Failure to comply may result in serious personal injury or death.

WARNING

High Pressure Fluid Hazard. When performing hydraulic test procedures, use the proper hydraulic gauge. Use properly rated hydraulic hoses with adequate length to allow the test gauge to be used far enough away from moving parts and functions. Failure to comply may result in serious personal injury or death.

WARNING

High Pressure Fluid Hazard. Hydraulic systems operate under high pressure. Only qualified, experienced people properly trained in hydraulic system maintenance should attempt repairs or troubleshoot hydraulic systems. Use the proper tools and equipment when servicing the hydraulic system. Use only the Revolution charging kit when recharging the accumulator. Failure to comply may result in serious personal injury or death. Please contact Revolution at (888) 209-6497 if you require assistance.

 **WARNING**

Crush Hazard. Hydraulics components can be heavy. Use caution while lifting these components. Failure to comply may result in serious personal injury or death.

 **WARNING**

Leak Hazard. Inspect the hydraulic reservoir on a daily basis. If you find any damage to the hydraulic reservoir, it must be repaired before the vehicle is returned to service. Never operate the hydraulic system if a leak is present. Failure to comply may result in serious personal injury or death.

 **WARNING**

Never alter the original equipment manufacturer's design. Hydraulic pressures and component functioning speeds are set before the vehicle is shipped to the customer. Failure to comply may result in serious personal injury or death and void the mixer vehicle warranty.

 **WARNING**

When using the emergency jumper procedure to rotate the drum on a disabled Mixer, the following must be observed: Before removing the hydraulic motor or hoses from the Mixer drive on both the operating and disabled Mixer, be sure the drum has been allowed to turn freely so that it is balanced with no forces transmitted to the hydraulic motor. Failure to comply may result in serious personal injury or death and void the mixer vehicle warranty.

⚠ WARNING

High Pressure Fluid Hazard. Correct hoses, fittings, and adapters with the correct SAE rating must be used when replacing hoses to prevent possible serious injury. Always replace hoses, fittings, and adapters with replacements that have a proper, suitable working pressure rating. Replacement hoses must be of correct length and must comply with the hose manufacturer's installation guidelines and recommendations. Hydraulic hoses have the SAE ratings marked on the hose to assist you in selecting the correct hose. Any replacement hydraulic hoses and fittings assemblies must be supplied by the same manufacturer. As an example: Brand "A" hose and brand "B" fitting will not normally be compatible. No "twist" is allowed in the hydraulic hoses. "Twist" may result in premature hose failure. For best results, always use genuine Revolution replacement parts. Failure to comply may result in serious personal injury or death.

⚠ WARNING

High Pressure Fluid Hazard. Any hydraulic tubing which is replaced must conform to SAE J1065 specifications. Damaged or leaking tubing must be replaced before the Mixer is returned to service. Please contact Revolution Concrete Mixers at (888) 209-6497 if you require assistance or have questions. Failure to comply may result in serious personal injury or death.

⚠ WARNING

High Pressure Fluid Hazard. Do not heat hydraulic pipe/tubing. The carbon content of this steel tube is such that if heated for bending, and either water or air quenched, the pipe may lose its ductility and thereby be subject to failure under high pressure or hydraulic shock conditions. Damaged or leaking pipes/tubing must be replaced before the Mixer is returned to service. Please contact Revolution Concrete Mixers at (888) 209-6497 if you require assistance or have questions. Failure to comply may result in serious personal injury or death.

3.6 Electrical

 **WARNING**

Fire Hazard. Electrical wiring, battery wiring, and electrical cable must be inspected on a daily basis for cuts, abrasions, damage, aging, improper clearance, and along the frame for hidden damage. Please contact Revolution Concrete Mixers at (888) 209-6497 if you require assistance or have questions. Failure to comply may result in serious personal injury or death.

 **WARNING**

Unintended Motion Hazard. Proximity switches must remain functional for safe operation of the mixer vehicle. If a switch does not work or has been tampered with or damaged, it must be replaced immediately with an OEM switch before the mixer vehicle returns to service. Failure to comply may result in serious personal injury or death. Contact Revolution at (888) 209-6497 for assistance if required.

 **WARNING**

Always check body/vehicle lights on the chassis or on the vehicle body. (Note: Not all models have indicator lights.) Replace bulbs or lights when required. Failure to inspect lights may lead to more serious conditions. Failure to comply may result in serious personal injury or death.

 **WARNING**

Electrocution Hazard. Do not remove the cover or back from monitors, control modules, cameras, or other electronic devices. No user serviceable parts are present inside these components. Do not attempt to cut, splice, or repair power and control cables included with these components. Replace with new components if damaged. Refer servicing to qualified personnel only. Failure to comply may result in serious personal injury or death and void the mixer vehicle warranty.

3.7 Chute Extensions

WARNING

Do not repair metal or composite chute extensions. Failure to comply may result in serious personal injury or death.

WARNING

Do not over-load chute extensions. Maximum load capacity of 400 lbs. per chute extension. Failure to comply may result in serious personal injury or death.

DANGER

Crush Hazard. Chute extensions must be secured on the truck before leaving the job site. Failure to comply will result in serious personal injury or death.

CAUTION

Never clean chute extensions by striking or chiseling. Failure to comply may cause damage to property or equipment.

WARNING

Inspect chute extensions prior to each use. Never use a damaged chute extension or a chute extension that has been driven over. Replace damaged chutes extensions immediately. Failure to comply may result in serious personal injury or death.

DANGER

Crush Hazard. Never stand on a chute or chute extensions. Do not use the chute as a crane to pull or transport objects. Failure to comply will result in serious personal injury or death.

 **CAUTION**

Crush Hazard. Do not use more chute extensions than are specified for your Mixer. Do not use any other type or style of chute extensions, other than ones designed for use with your Mixer. Do not combine the use of metal and composite chute extensions during operational use. Failure to comply may cause damage to property or equipment.

 **WARNING**

Crush Hazard. Do not use more than 12 feet of extension chutes. A total extension chute length greater than 12 feet can cause the chute to collapse without warning. Do not use any other type or style of chute extensions, other than ones designed for use with your Mixer. Make sure that no one ever walks under a loaded chute. Failure to comply can result in serious injury or death.

 **DANGER**

Flammable Hazard. Any urethane parts are flammable. Do not expose to an open flame or a temperature exceeding 220°F (104°C). Burning urethane parts produce toxic smoke/fumes during combustion. Failure to do so will result in serious personal injury or death.

NOTES

1.0 Exterior Systems Arrangement

1.1 Curb Side View

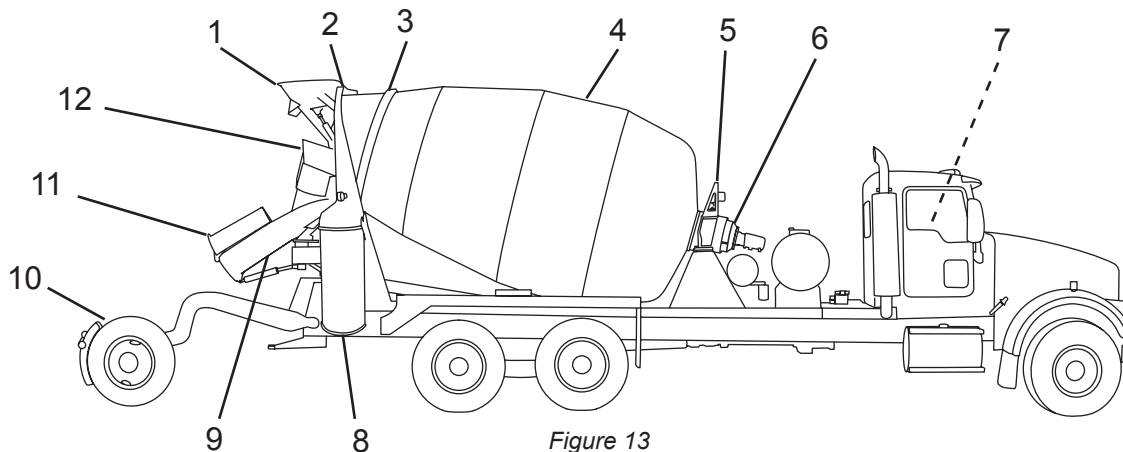

Figure 13

Ref No.	System Description
1	Charge Hopper
2	Debouncer
3	Drum Roller Track (Ring)
4	Drum
5	Hydraulic Oil Cooler (Location May Vary)
6	Drum Drive

Ref No.	System Description
7	Cab Control Box or Cab Pendant
8	Chute Extensions (Location May Vary)
9	Main Chute
10	Bridgemaster Axle
11	Fold-Over Chute
12	Collector

1.2 Street Side View

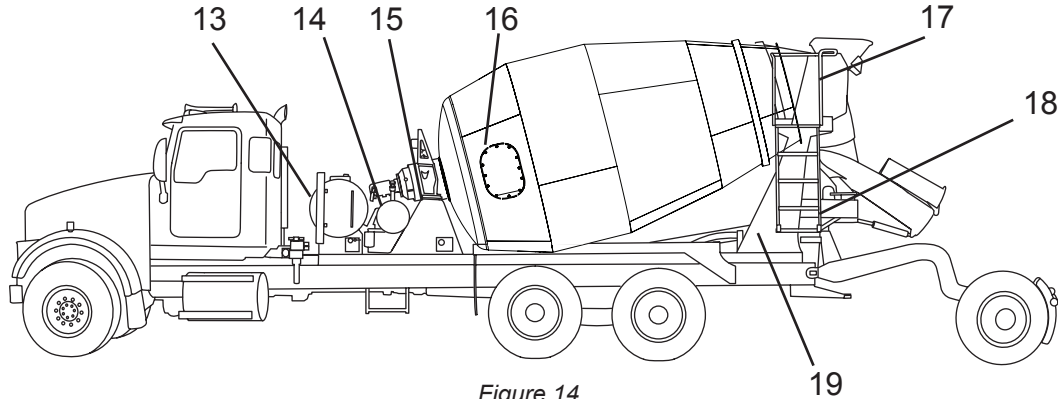

Figure 14

Ref. No.	System Description
13	Water Tank (Location May Vary)
14	Hydraulic Oil Reservoir (Location May Vary)
15	Front Pedestal
16	Drum Hatch
17	Drum Access Ladder
18	Rear Control Pendant
19	Rear Pedestal

1.0 Before Placing the Mixer Into Service

After delivery, it will be necessary to prepare the Mixer for normal operation.

1. Remove cable ties securing the access ladder.
2. Deactivate the Transport Lock using the control display.
3. Securely mount the emergency equipment.
 - a. Mount the fire extinguish in an area that is readily accessible, and in a manner that prevents sliding, rolling, or vertical movement.
 - b. The mounting location of the triangle kit and spare fuse kit is at the discretion of the final user.
4. Attach and securely stow wash-out hose(s).
5. Inspect all mounting hardware to see if any has loosened during delivery. Retighten hardware as needed.
6. Inspect all hydraulic lines and hoses for leaks.
7. Charge the Mixer with a quantity of stone and sand. Rotate the drum for 1-1/2 to 2 hours to clean the interior of any weld slag or splatter. This will polish the blades and reduce the possibility of concrete adhering to the drum interior.

1.1 INSIGHT System Deactivate Transport Feature

The system is programmed with a transport feature that commands the drum to rotate in the charge direction at approximately 1 to 1-1/2 RPM whenever the chassis engine is running. This feature is required to prevent damage to the drum rollers during delivery.

NOTE

After the chassis engine start, there may be a slight delay before drum rotation starts in the CHARGE direction.

The transport feature is deactivated and activated through the touch screen control display.

1. Enter the Fleet Manager Code. Contact Revolution at (855) 202-6491 to receive the code.
2. Touch the ENTER PASSWORD TO UNLOCK button.

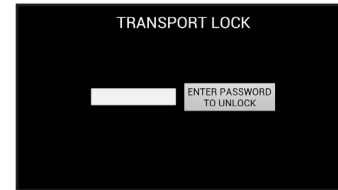

Figure 15

Operation

1.2 Traditional Controls Deactivate Transport Feature

After delivery, it will be necessary to prepare the Mixer for normal operation.

1. Remove the cable tie (Figure 16, Item 1) securing the hydraulic pump linkage in the TRANSPORT mode. The TRANSPORT mode constantly rotates the drum in the CHARGE direction at a speed of 1 to 1-1/2 RPM. This prevents the drum rollers from becoming damaged during transport.
2. Install the cab chute control fuse.

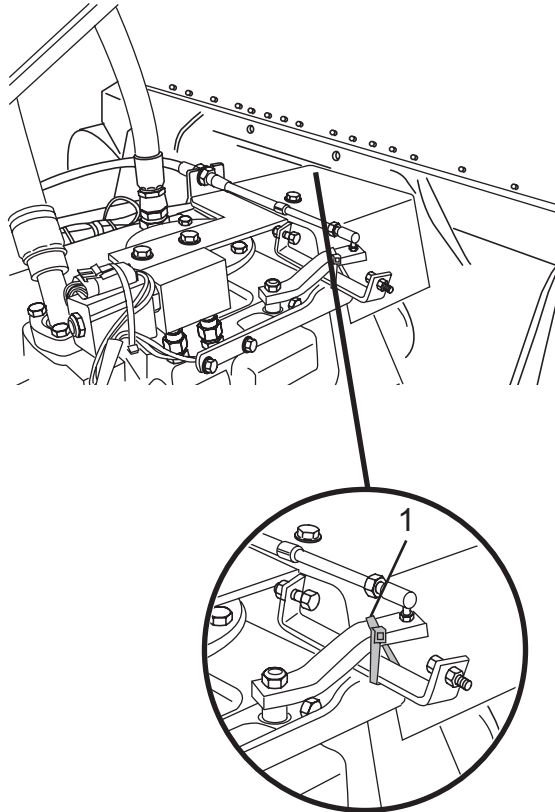

Figure 16

2.0 INSIGHT Mixer System Instruments and Controls

The following figures and tables identify and describe the controls used on this equipment. These instructions include optional features that may or may not be included on your Mixer. To make sure you understand proper operating procedures, read this section and carefully practice with the controls and instruments to learn how to safely operate the equipment.

The INSIGHT Mixer System consists of a monitor (Figure 17) that has indicator icons to display the status of functions.

2.1 Home/Drum Screen Overview

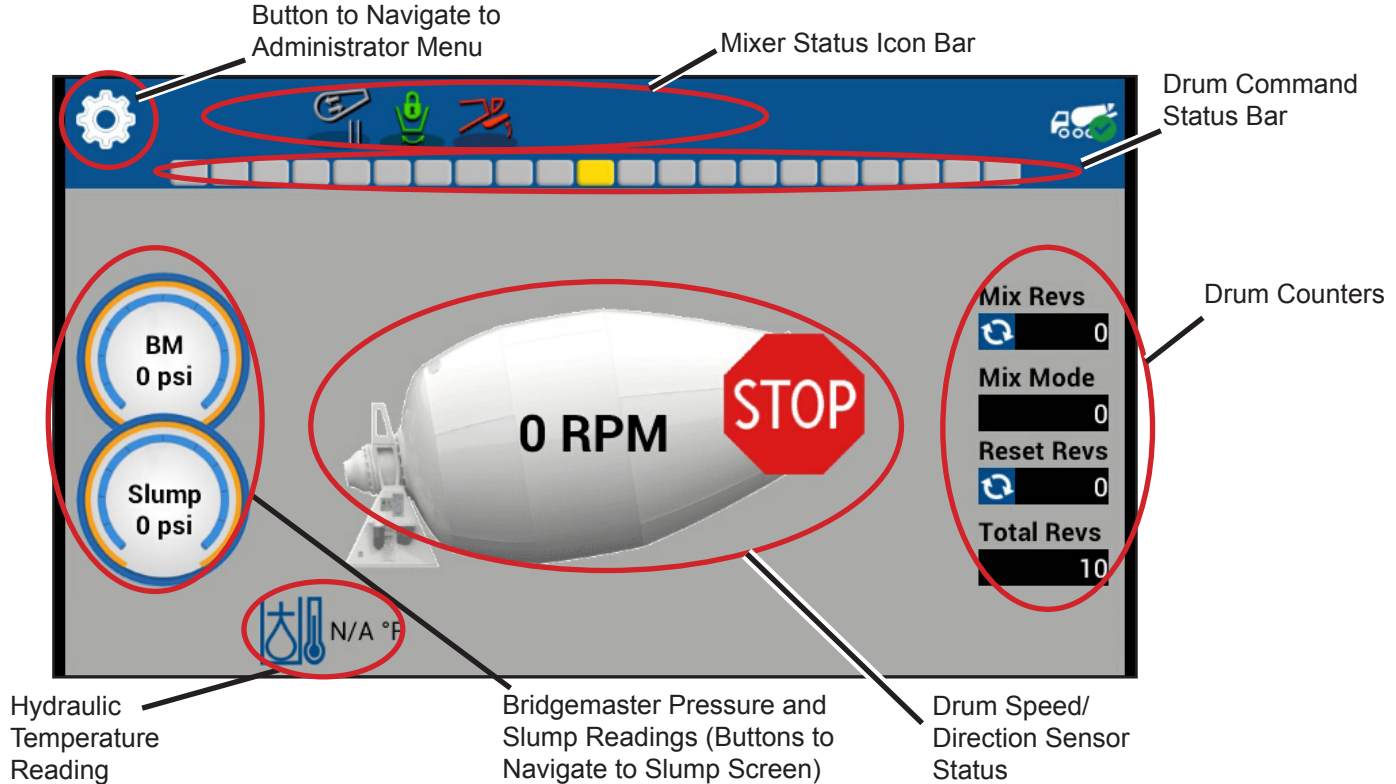
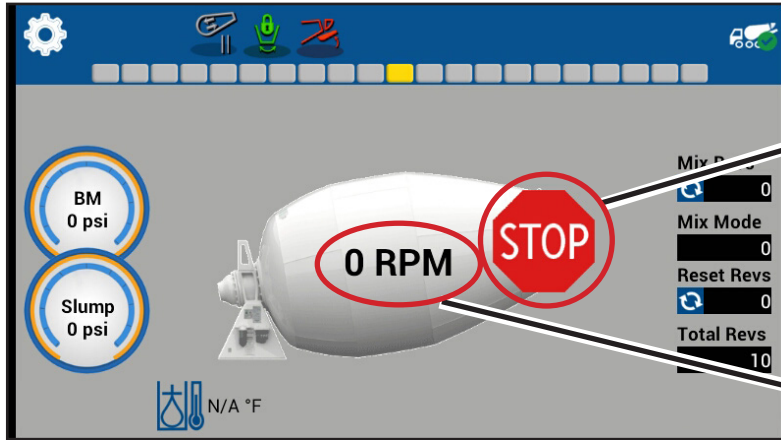

Figure 17

2.2 Speed/Direction Sensor Reading Screen Overview



Signifies the Drum's Direction based on Sensor Reading

Signifies the Drum's Speed Based on Sensor Reading

Direction: Charge
Speed: 4.8 Drum RPM

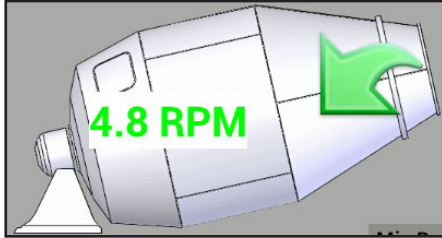

Direction: Stopped
Speed: 0 Drum RPM

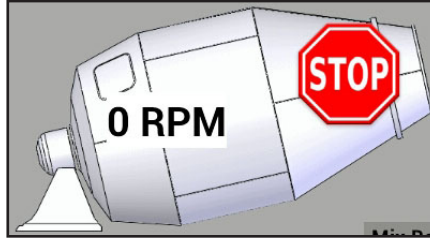

Direction: Discharge
Speed: 1.3 Drum RPM

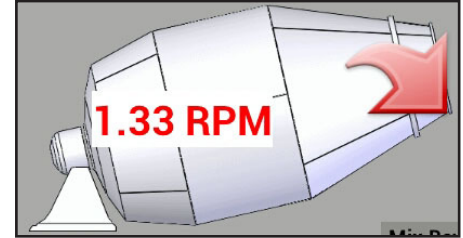

Figure 18

2.3 Drum Revolution Counter Screen Overview

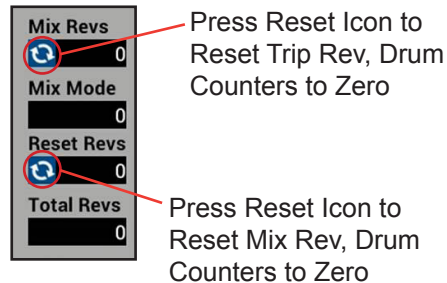
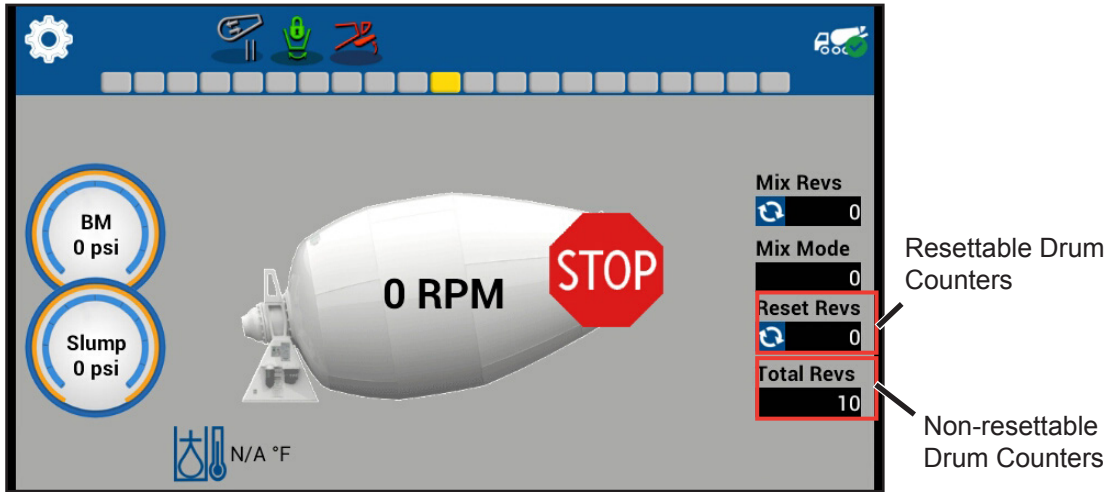

Figure 19

2.4 Auxiliary Function Icons

These instructions include optional features that may or may not be included on your Mixer.

Press the icon to enable or disable the auxiliary function.

- Remote PTO mode (Figure 20, Item 1). The icon will be grayed out if not turned on.
- Hydraulic Fan (this function is already engaged if the temperature is over 140°F) (Figure 20, Item 2). The icon will be grayed out if not turned on.
- Work Lights ON in Reverse (Figure 20, Item 3). Use work lights on in reverse at a job site only. Using work lights on in reverse while on the roadway is not recommended and may not comply with applicable laws. The icon will be grayed out if not turned on (shown in Figure 20, Item 3).

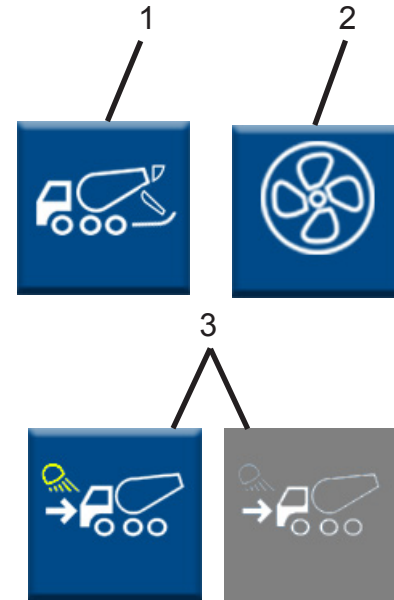

Figure 20

Operation

2.4.1 INSIGHT Mixer System Enabled Package

NOTE: Not all INSIGHT mixers are equipped with all features.

Constant Speed Modes

Constant Speed Modes will control the number of drum revolutions when activated. These presets can be changed within the Fleet Manager Mode.

- Empty (Figure 21, Item 1). Spins the drum at 1 RPM in Constant Speed.
- Wet (Figure 21, Item 2). Spins drum at 5 RPM Low Constant Speed and 12 RPM High Constant Speed.
- Standard (Figure 21, Item 3). Spins drum in two configurable constant speeds (Low: 1-3 RPM; High: 3.1-7 RPM).
- Dry (Figure 21, Item 4). Spins the drum at 1.5 RPM in Constant Speed.

Mix Modes

- Mixing Admix (Figure 21, Item 5). Throttles up the truck to mixing speed and mixes for 30 revolutions before returning to Constant Speed.
- Mixing Water (Figure 21, Item 6). Throttles up the truck to mixing speed and mixes for 70 revolutions before returning to Constant Speed.

Drum Reactivity Modes

- Smooth (Figure 21, Item 7). Allows drum to transition to new direction/velocity with dampening to minimize wear. This is the recommended operating mode.
- Legacy (Figure 21, Item 8). Allows quick transition (faster transition than “Smooth”) to new direction/velocity without dampening.

Auxiliary Functions

- Admixture (Figure 21, Item 9). Allows addition of prescribed amount directly into drum, and record amount added and time of addition.
- Buildup (Figure 21, Item 10). Starts a buildup test on the drum to determine if there is ~2000 lbs. of buildup. The system performs the drum test controlling the drum for approximately one minute. The system then prompts the operator: No buildup detected; Test conditions not met; Possible buildup. Test should be performed on a regular schedule for the most accurate reading. Revolution recommends once daily.
- Washout (Figure 21, Item 11). Allows selection of up to 4 washout zones. Each zones will wash for predetermined set of time.

- Water (Figure 21, Item 12). Allows addition of prescribed amount of water directly into the drum, records amount added, and time of addition.
- Slump Calibration (Figure 21, Item 13). This screen is used to load and save slump calibrations. These values are used for the inch readouts for the Slump gauges used on the Drum and Slump screens. See 12.12 Concrete Slump Meter and 12.12.2 Setting the Digital Concrete Slump Meter for INSIGHT System Only for more information.
- Auto Load Mode (not shown). The system will monitor the hydraulic pressure until a pressure increase is detected and then change to Load Mode (increasing drum RPM to load mode speed using throttle control). Auto Load can be actuated by simultaneously pressing the unlock key and load key.
- GradeGuard (optional feature) (not shown). When the mixer is equipped with GradeGuard, drum will switch to high Constant Speed when the mixer detects it is climbing greater than 4% grade.

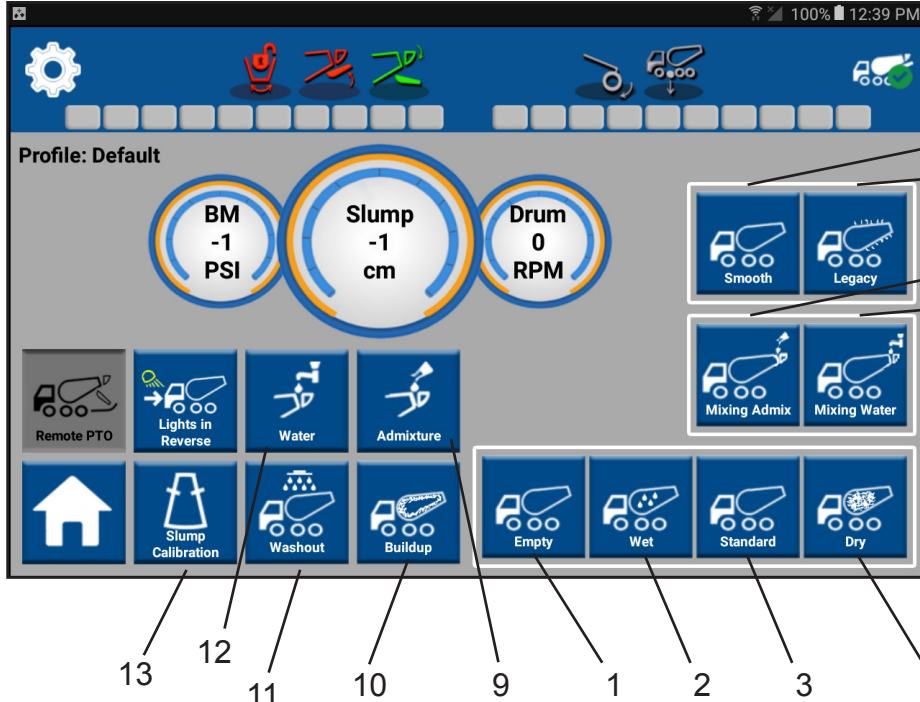

Figure 21

2.5 Touch Screen Display Button Overview

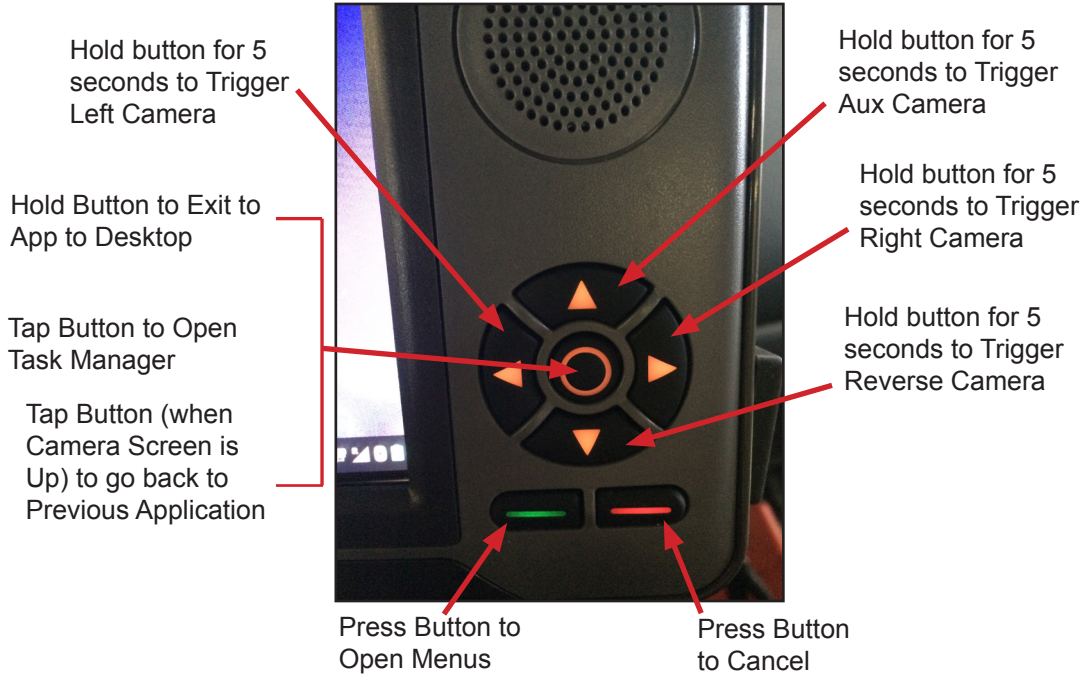

Figure 22

Operation

2.6 Touch Screen Display Status Icons



Bridgemaster Down



Bridgemaster Up



Chute Locked



Chute Unlocked



Chute Down



Chute Up



Drum Charge



Drum Discharge



Hopper Up



Hopper Down



Load Mode



Mix Mode



Work Lights On



Strobe Lights On



Add Water (Optional Equipment)



AdMix (Optional Equipment)



Hydraulic Temperature



Hydraulic Fan

2.7 Cab Control Keypad (Standard)

The in-cab controls consist of a control keypad and an optional joystick (Figure 23). Accessories and mixer functions and some options are operated by buttons on the cab control keypad (Figure 23). The actual buttons present on the control keypad will vary, depending on the configuration of your Mixer.

No.	Item	Description
1	Strobe Lights	LED on when strobe lights are ON. Press to turn on or off.
2	Perimeter Lights	LED on when perimeter lights are ON. Press to turn on or off.
3	Work Lights	LED on when work lights are ON. Press to turn on or off.
4	Hopper Up/Down	Green LED when air hopper is DOWN. Red LED when air hopper is UP.
5	Chute Up	Green LED while button is pressed.
6	Pusher Axle Up	Green LED while button is pressed.
7	Chute Lock/Unlock	Green LED when locked and Red LED when unlocked.

Operation

No.	Item	Description
8	Chute Down	Green LED while button is pressed.
9	Pusher Axle Down	Green LED while button is pressed.
10	Drum Pause/Resume*	Stops the drum rotation.
11	Chute Swing Left	Moves chute to the left (Power Chute Swing Option only). Green LED is on when button is pressed.
12	Chute Swing Right	Moves chute to the right (Power Chute Swing Option only). Green LED is on when button is pressed.

* Mixers with Cable Control will have this function if they have the Start/Stop valve.

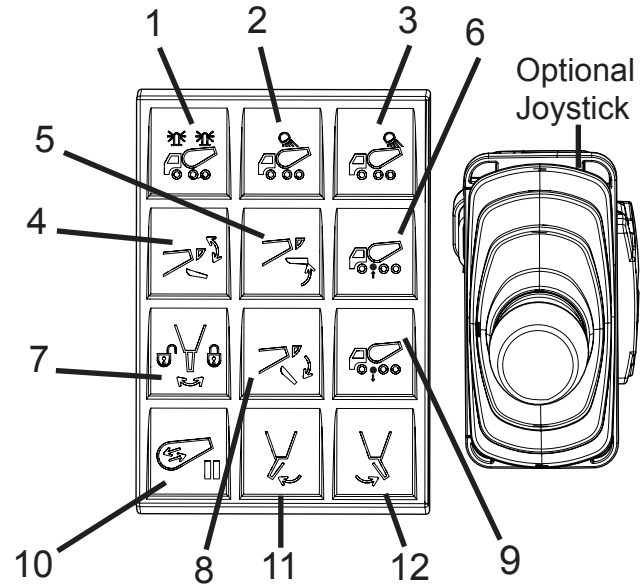

Figure 23

2.8 Cab Control Keypad (Optional)

The optional in-cab keypad controls some accessories and mixer functions (Figure 24). The actual buttons present on the control keypad will vary, depending on the configuration of your Mixer.

No.	Item	Description
1	Constant Speed Mode*	LED is green when in constant speed mode. Constant speed will automatically engage if going over preset speed.
2	Mix Mode*	Turns drum at preset speed for a preset number of revolutions by ramping engine speed. Truck must be in Park/Neutral, parking brake must be set to active, and Cruise Control Switch turned on.
3	Load Mode*	Turns drum at maximum speed for loading purposes by ramping engine speed. Truck must be in Park/Neutral, parking brake must be set to active, and Cruise Control Switch turned on.

No.	Item	Description
4	Bridgemaster Axle Up	LED on when Bridgemaster Axle is UP.
5	Activate	Press and hold the button and Bridgemaster function buttons.
6	AdMixture Add	OPTIONAL EQUIPMENT: LED on when AdMixture Add button is pressed.
7	Bridgemaster Axle Down	LED on when Bridgemaster Axle is DOWN.
8	Bridgemaster Axle Stop	LED is red while axle is stopped.
9	Water Add	OPTIONAL EQUIPMENT: LED on when add water is enabled.
10	Joystick Enabled/ Disabled	Indicates if joystick is enabled (green) or disabled (red).
11	Drum Charge*	LED is green while charging.
12	Drum Discharge*	LED is green while discharging.

* Mixers with Cable Control will not have this function.

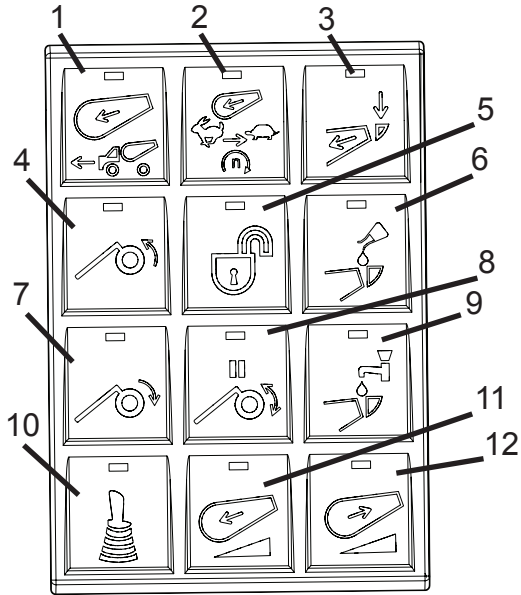

Figure 24

2.9 Optional Joystick for Chute Lock/Unlock, Chute Up/Down Functions

The Mixer may be equipped with an optional joystick that controls chute lock/unlock, main chute up, and main chute down (Figure 25). If equipped, this joystick is found as part of the in-cab control box.

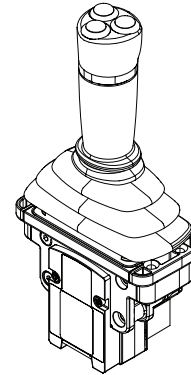
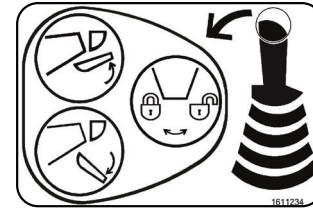

Figure 25

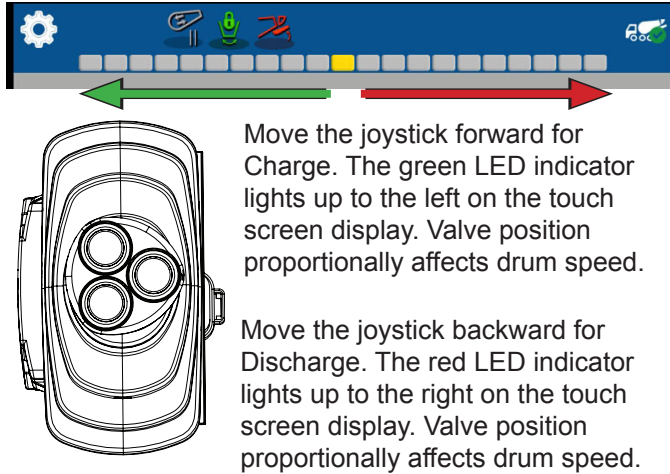

Figure 26

2.10 Outside Controls

The outside controls consist of a rear pendant keypad (Figure 27, Item 1), a manual chute lock (Figure 27, Item 2), and a cable drum control for cable control mixers only (Figure 27, Item 3).

No.	Item	Description
1	Rear Control Pendant Keypad	Contains digital push buttons to control various mixer functions.
2	Cable Drum Control	For Cable Drum Control Mixers Only. Drum charge, discharge, and stop are controlled by the cable.
3	Manual Chute Lock	Mechanically locks the discharge chute in one of several positions.

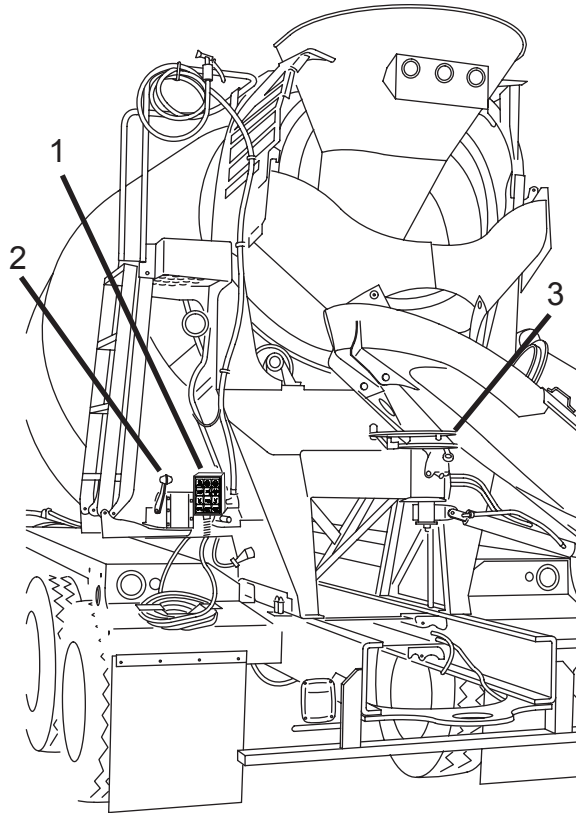

Figure 27

2.10.1 Rear Pendant Control Keypad

Accessories and mixer functions and some options are operated by buttons on the rear control pendant keypad (Figure 28). The actual buttons present on the control pendant will vary, depending on the configuration of your Mixer. The operator can take the rear pendant up the ladder platform for quick access to starting and stopping the drum.

No.	Item	Operation
1	E-STOP	E-STOP on/off button. To reset, press and hold button for 5 seconds.
2	Throttle Down	Slows the engine throttle. Truck must be in Park/Neutral, parking brake must be set to active, and Cruise Control Switch turned on.
3	Throttle Up	Speeds engine throttle. Truck must be in Park/Neutral, parking brake must be set to active, and Cruise Control Switch turned on.

No.	Item	Operation
4	Hopper Up/ Down	Green LED when air hopper is DOWN. Red LED when air hopper is UP.
5	Chute Up	Green LED while button is pressed.
6	Chute Lock/ Unlock	Green LED when locked and Red LED when unlocked.
7	Chute Swing Left	Moves chute to the left (Power Chute Swing Option only). Green LED is on when button is pressed.
8	Chute Down	Green LED while button is pressed.
9	Chute Swing Right	Moves chute to the right (Power Chute Swing Option only). Green LED is on when button is pressed.
10	Drum Stop*	Stops drum rotation.
11	Drum Charge**	Speeds drum while charging and slows drum while discharging. Green LED while charging.

No.	Item	Operation
12	Drum Discharge**	Speeds drum while discharging and slows drum while charging. Green LED while discharging.

* Mixers with Cable Control will have this function if they have the Start/Stop valve.

** Mixers with Cable Control will not have this function.

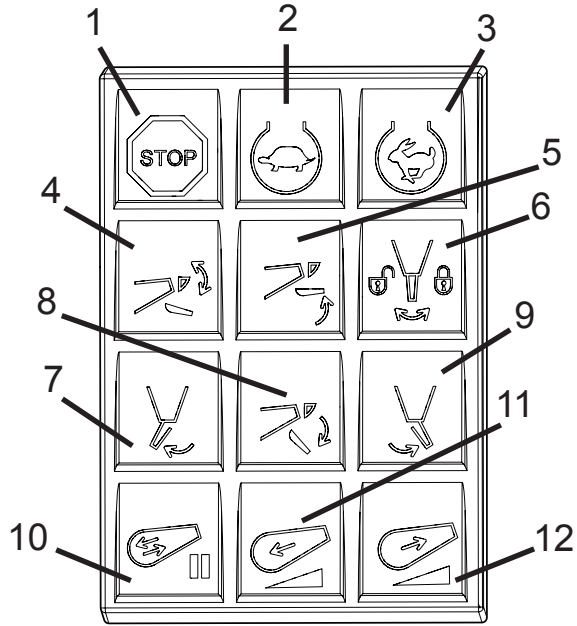

Figure 28

2.10.2 Cable Drum Control (If Equipped)

Certain Bridgemaster Mixers will have the drum controlled by a rear cable (Figure 29) instead of electronically on the keypad. Drum charge and discharge are controlled by the cable.

No.	Control	Normal Use or Reading
1	DRUM CONTROL LEVER (CHARGE/DISCHARGE)	<p>Starting at the NEUTRAL position, pushing the lever forward (away from the operator) starts the drum rotating in the CHARGE direction. The farther the lever is pushed forward, the faster the drum rotates.</p> <p>Pulling the lever back (toward the operator) will decrease the drum speed until the NEUTRAL position is reached at which point the drum stops rotating.</p> <p>From the NEUTRAL position, pulling lever back (toward the operator) will start the drum rotating in the DISCHARGE direction. The farther the lever is pulled back, the faster the drum rotates.</p>

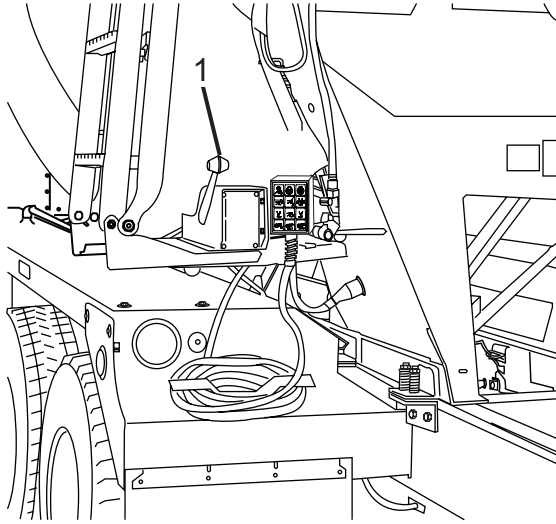

Figure 29

2.10.3 Manual Chute Lock

CAUTION

Unintended Motion Hazard. Do not move the vehicle without locking the chute with the manual chute lock. Do not use the chute air lock to secure the chute for transport. Failure to comply may cause damage to property or equipment.

The manual chute lock mechanically locks the chute in one of several predetermined positions.

To move the chute:

1. Unlock the chute air lock (if equipped).
2. While holding the chute, pull down on the lever (Figure 30, Item 1) and move it to the right or left until the lever is seated in one of the lock positions.
3. Move the main chute (Figure 30, Item 2) to the desired position, and while holding the chute, move the lever to the center. Make sure the lever pin is fully seated into one of the holes in the chute plate before releasing the chute. Move the chute from side to side as needed to align the pin and hole.

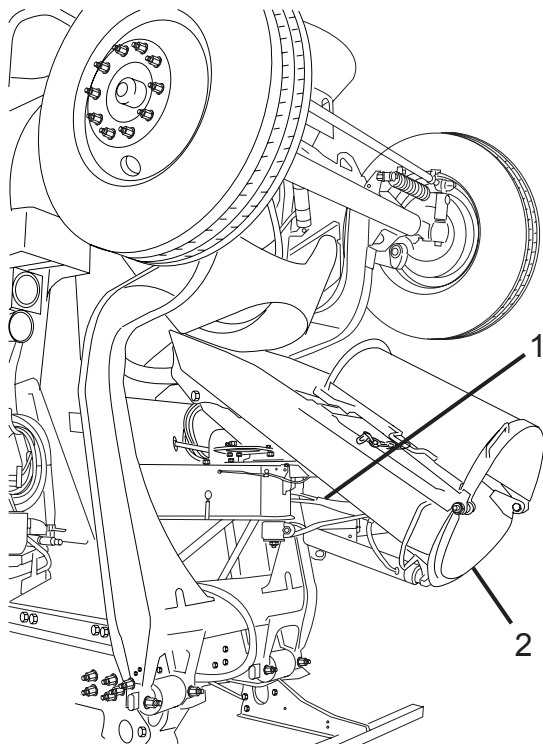

Figure 30

2.11 Fuse Functions

If a function on the cab control keypads or rear pendant control keypad does not operate, check the condition of the fuses located in the cover of the control fuse box (in the cab control pendant) or the rear of the control box (cab control box). A label is located beside the fuses to identify the functions they control. If a fuse is blown, its indicator light will be flashing on the Power Distribution Module Splash Screen on the monitor (Figure 31).

CAUTION

Do not replace a fuse with a higher amperage fuse than is listed for the location. Always use new fuses of the correct amperage. Failure to comply may cause damage to property or equipment.

Fuse No.	Amperage Rating	Description
F1	20 amps	Body Function 1 Power
F2	15 amps	Body Function 2 Power
F3	10 amps	Perimeter Lights Power
F4	25 amps	Fan Power
F5	10 amps	Strobe Lights Power

Operation

Fuse No.	Amperage Rating	Description
F6	5 amps	Sensor Power
F7	10 amps	Cab/HMI Power
F8	10 amps	Work Lights Power
F9	10 amps	Optional Power
F10	10 amps	Optional Power
F11	10 amps	Optional Power
F12	10 amps	Chute Power
F13	10 amps	Optional Power
F14	10 amps	Optional Power
F15	10 amps	Optional Power
F16	15 amps	Main Control Module Power

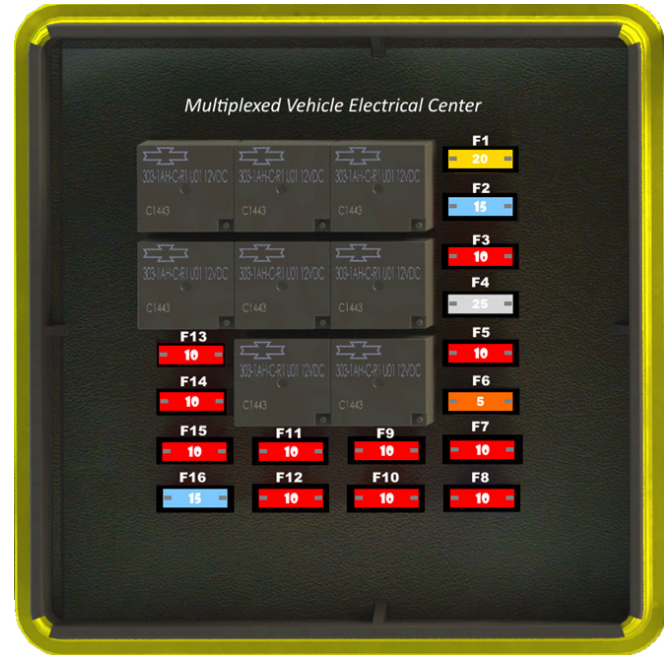

Figure 31

2.12 Manual Drum Operation

2.12.1 EP Controls

2.12.1.1 Manual Override - CHARGE and DISCHARGE

NOTE

Use manual pump overrides for emergency use only. When engaged, drum rotates at speed determined by the pressure applied to override button.

To manually override the mixer controls:

1. Locate the manual override buttons (Figure 32, Items 1 or 2) on the electronic displacement control valve.

NOTE

CHARGE and DISCHARGE override button positions will vary depending on mixer pump configuration.

2. To engage the drum drive, push the black rubber button to start the drum rotation in the CHARGE or DISCHARGE direction. You must continue to hold the button in, or the drum will return to neutral

(the control valve is spring loaded to the neutral position). The more pressure is exerted on the button, the faster the drum will rotate.

3. If the drum controls are still disabled after unloading, see Manual Override - Locking for Transit to configure the drum drive for transit.

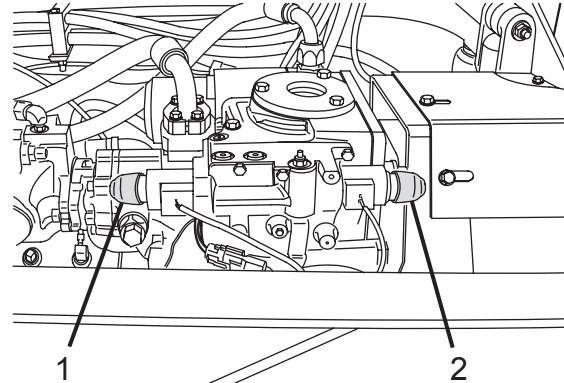

Figure 32

2.12.1.2 Manual Override - Locking for Transit

SAFETY NOTICE

Always rotate drum when truck is in motion. Never stop the drum while driving. Driving the truck without the drum rotating will damage equipment. Failure to comply may cause damage to property or equipment.

NOTE

Use manual pump overrides for emergency use only.

In the event of an electrical failure, the pump neutral adjustment screw (Figure 33, Item 1) can be adjusted to temporarily “lock” the drum in the CHARGE position to allow the truck to be driven to the shop for repair.

NOTE

The drum speed will increase when rotating the pump neutral adjustment screw, until the drum reaches maximum speed. If the screw is turned past maximum speed, the drum will reverse direction.

To manually rotate the drum:

NOTE

An adjustable wrench and standard (slotted) screwdriver are required to adjust the neutral adjustment eccentric screw.

1. If the control valve on your pump has a guard, use a screwdriver to remove the two guard screws and guard.
2. Loosen the adjustment eccentric screw lock nut (Figure 33, Item 2) using a 9/16” wrench.
3. Using a screwdriver, rotate the pump neutral adjustment eccentric screw (Figure 33, Item 1) until the drum is rotating at approximately 1 to 1-1/2 RPM in the CHARGE direction.
4. Hold the pump neutral adjustment eccentric screw (Figure 33, Item 1), while tightening the lock nut (Figure 33, Item 2) with the 9/16” wrench.
5. Once the truck is delivered to the repair shop and properly parked, return pump neutral adjustment eccentric screw to neutral position.
6. Remove the Mixer from service until repairs are completed.

7. Call Revolution Service at (855) 202-6491 if you have questions or need help.

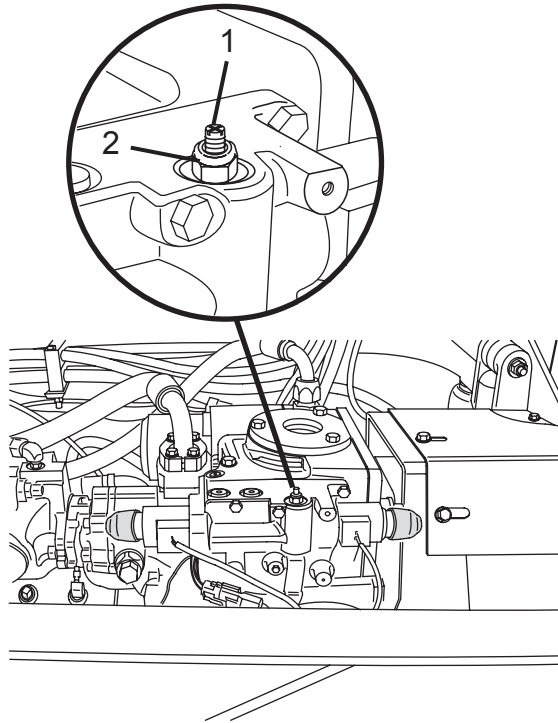

Figure 33

3.0 Control Functions for INSIGHT System

3.1 Start-Up Function

After the chassis engine is started, drum control by the CHARGE and DRUM START/STOP buttons will not be allowed until the DRUM START/STOP light and CONSTANT SPEED light (Figure 34, Item 1) are OFF.

Select initial mode of drum operation (optional in-cab control keypad, joystick if equipped, or rear pendant keypad). If no mode is selected, the default mode is cab keypad.

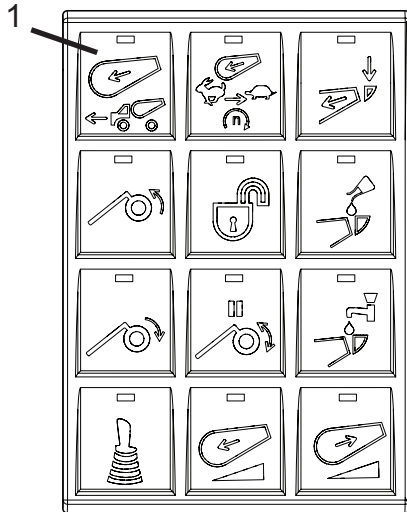

Figure 34

3.2 Rotating the Drum from the Joystick, Optional In-Cab Keypad, or Rear Pendant Keypad

The drum can be set to rotate by either the joystick, in-cab keypad, or the rear pendant keypad.

- If the joystick mode is activated, move the joystick in the desired direction for drum rotation.
- If in-cab keypad or rear keypad pendant is selected, keep pressing the CHARGE (forward) (Figure 35, Item 1) or DISCHARGE button (backward) (Figure 35, Item 2) until the desired rotation speed is achieved. You may also press and hold the charge or discharge keypad buttons until desired rotation speed is achieved. The key indicators will illuminate only when pressed.

Monitor drum speed on the home screen of the touch screen monitor and adjust as necessary. The display will show the speed of and direction of (charge or discharge) drum.

Operation

3. Press the appropriate button, either Charge (Figure 37) or Discharge (Figure 37), on the Wireless Transmitter.
 - Drum Charge: Push to speed up drum while charging or to slow drum while discharging
 - Drum Discharge: Push to speed up drum while discharging or to slow drum while charging

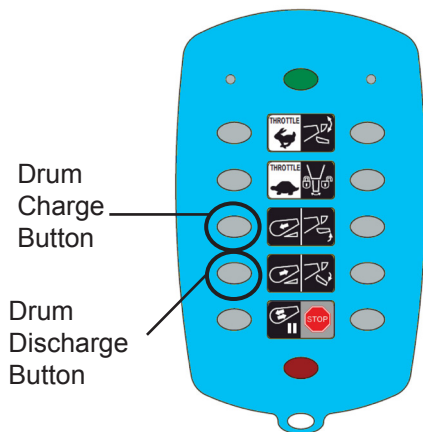

Figure 37

3.4 Drum Stop Operation

The following procedures are to stop the drum rotation using the standard in-cab keypad or the rear pendant keypad (Figure 38, Item 1), or Wireless Transmitter (Figure 39).

1. The Drum STOP button must be off (light is off) upon truck start-up for drum rotation. The drum will stop immediately.
2. While drum is turning in either direction, press the STOP control button at any control station. The indicator light will illuminate red and the drum will stop.
3. To resume drum operation, push STOP button. The indicator light will go out and the drum will re-start in the same direction and speed prior to the STOP event.

Standard In-Cab Keypad

Rear Pendant Keypad

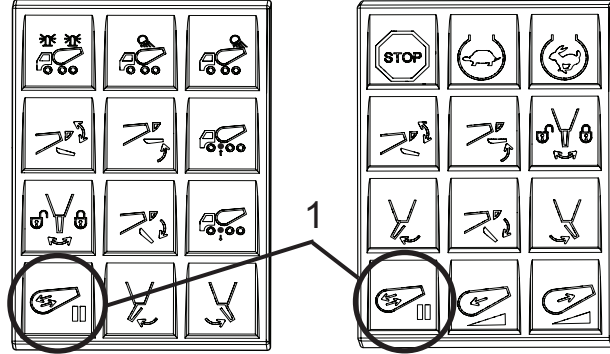

Figure 38

Wireless Transmitter

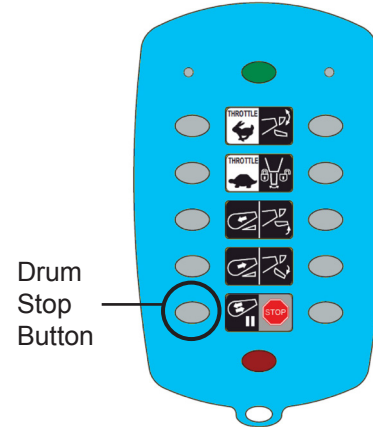

Figure 39

Operation

3.5 Load Function (If Equipped - Electronic Drum Controls Only)

The Load function button is located on the optional in-cab control keypad only. The load function of the controls allows one-touch operation of the loading function. When the button is pressed, the engine RPM will go the full preset and the drum speed will accelerate to 18 RPM or to maximum drum speed based on rear engine PTO ratio and maximum engine RPM.

1. Pull or back the Mixer into the plant's load lane.
2. Position the charge hopper directly under the discharge chute at the batch plant.
3. Truck must be in Park/Neutral, parking brake must be set to active, and Cruise Control Switch turned on.
4. Press the LOAD button on the optional in-cab keypad (Figure 40, Item 1). The button indicator will illuminate. The LOAD icon will display on the drum control on the touch screen monitor.
5. The truck's engine will ramp to full preset and the drum will accelerate to 18 RPM in the charge direction.
6. When loading is complete, press the LOAD button or push the brake pedal or Constant Speed button.

The system will default to the Constant Speed preset (the Constant Speed button indicator will illuminate).

7. If manual drum control is desired, press the CONSTANT SPEED button (its indicator light will go out) and select the DRUM CONTROL mode.

Optional In-Cab Keypad 1

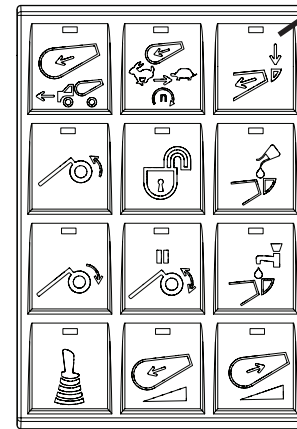

Figure 40

3.6 Mix Function (If Equipped - Electronic Drum Controls Only)

The Mix function button is located on the optional in-cab control keypad only. The MIX function of the controls allows for one-touch operation of mixing function prior to job pour. When pressed, the engine RPM will go to the full preset and the drum speed will accelerate to preset Mix RPM for a preset number of drum revolutions.

1. Truck must be in Park/Neutral, parking brake must be set to active, and Cruise Control Switch turned on.
2. Press the MIX button on the optional in-cab keypad (Figure 41, Item 1). The button indicator will illuminate. The MIX icon will display on the drum control on the touch screen monitor.
3. The truck engine will ramp to full RPM preset and the drum will accelerate to MIX RPM in the charge direction ONLY for a preset number of revolutions.
4. When mixing revolutions reach the preset, MIX mode will cancel engine and the drum will slow to IDLE and CONSTANT SPEED respectively. The system will then default to Constant Speed preset (the Constant Speed button indicator will illuminate).

5. If manual drum control is desired, press the CONSTANT SPEED button (its indicator light will go out) and select the DRUM CONTROL mode.

Optional In-Cab Keypad

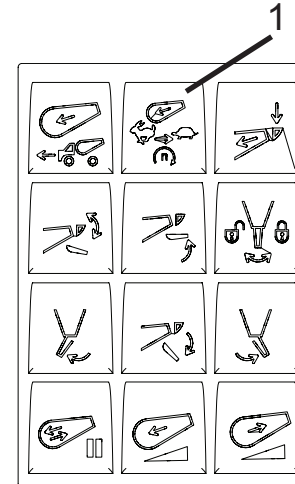

Figure 41

Operation

3.7 Constant Speed Function (If Equipped - Electronic Drum Controls Only)

The Constant Speed function maintains a constant preprogrammed speed (preset value between 1 and 3 RPM) in the charge direction for all engine RPM. The CONSTANT SPEED function button is located on the optional in-cab keypad only. The CONSTANT SPEED function of the controls allows for one-touch operation of a preset slow charge drum speed for transport to the job site without the need to manually adjust the controls.

NOTE: Constant Speed will automatically engage when either the LOAD or MIX modes are canceled or shut off and/or when the vehicle speed reaches a preset threshold.

1. To manually engage CONSTANT SPEED mode, press the CONSTANT SPEED button on the optional in-cab keypad (Figure 42, Item 1). The button indicator will illuminate when mode is selected. All other mixer drum inputs are disabled while this mode is activated.

NOTE: All other mixer drum inputs and rear throttle controls are disabled while this mode is activated.

2. To turn off, press the CONSTANT SPEED button again.

NOTE: Drum will return to RPM that was active prior to turning on Constant Speed mode.

Optional In-Cab Keypad

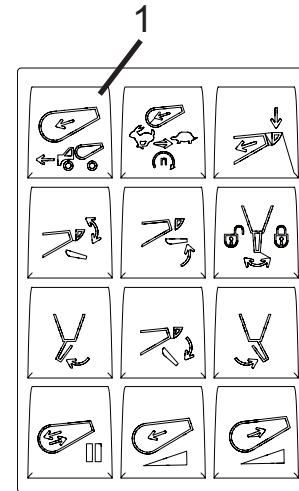

Figure 42

NOTE

If the drum Charge or Discharge function is activated, the Constant Speed Function will be activated immediately after pressing the Constant Speed switch.

If the drum Charge or Discharge function is NOT activated, the START/STOP switch must be pressed to activate the Constant Speed function.

When the Constant Speed Function is activated, the CHARGE and DISCHARGE switches are disabled on the cab and rear pendant controls.

Operation

3.8 Hopper Function

The Hopper function button is located on the standard in-cab keypad or the rear pendant keypad only. To activate the Hopper function, press the HOPPER function button on either the standard in-cab keypad or the rear pendant (Figure 43, Item 1).

NOTE: The Hopper UP or DOWN icons will display on the touch screen monitor.

The button indicator will illuminate when mode is selected. Indicator light is red when hopper is up and green when hopper is down.

OPERATIONAL NOTE: Upon truck startup, the Hopper will automatically move into the down position.

Standard In-Cab Keypad

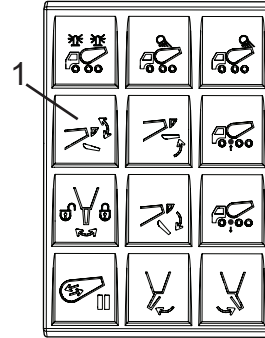

Hopper UP



Rear Pendant Keypad

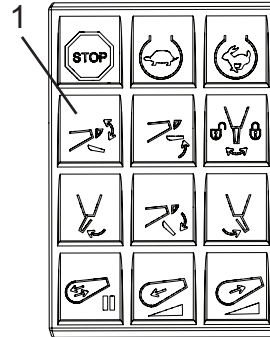

Hopper DOWN



Figure 43

3.9 Chute Lock Function

The Chute Lock function button is located on both the standard in-cab keypad and the rear pendant. To activate the Chute Lock function, press the CHUTE LOCK function button on either the standard in-cab keypad or the rear pendant (Figure 44, Item 1).

NOTE: The Chute Lock Unlocked or Locked icons will display on the touch screen monitor.

The button indicator will illuminate when mode is selected. Indicator light is red when unlocked and green when locked.

OPERATIONAL NOTE: Upon truck startup, cycle the Chute LOCK button until the “Chute LOCK” icon is illuminated on the touch screen.

Standard In-Cab Keypad

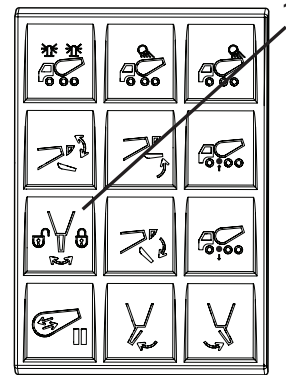

Rear Pendant Keypad

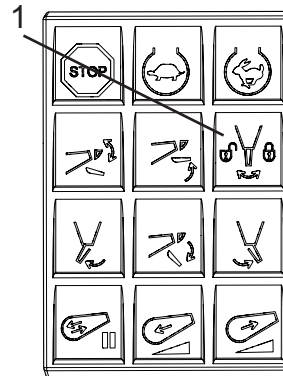

Chute
UNLOCKED



Chute
LOCKED



Figure 44

Operation

3.10 Chute Raise/Lower and Swing Functions

The Chute Raise/Lower function buttons and the Swing (left or right) function buttons are located on both the standard in-cab keypad and the rear pendant keypad (Chute Swing is an optional feature). To activate the Chute Raise/Lower or Swing functions, press the appropriate function buttons on either the standard in-cab keypad or the rear pendant keypad (Figure 45). Press and hold the desired function button until desired movement is achieved.

Indicator lights will illuminate green only when pressed. Indicator lights will illuminate solid green when the chute is down and centered.

Ref.	Function
1	Chute UP
2	Chute DOWN
3	Chute Swing LEFT
4	Chute Swing RIGHT

Standard In-Cab Keypad

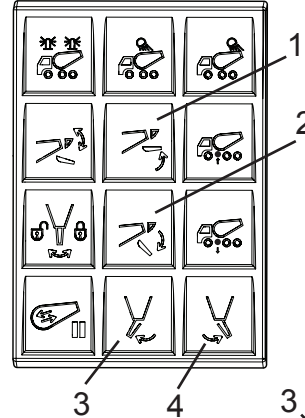

Rear Pendant Keypad

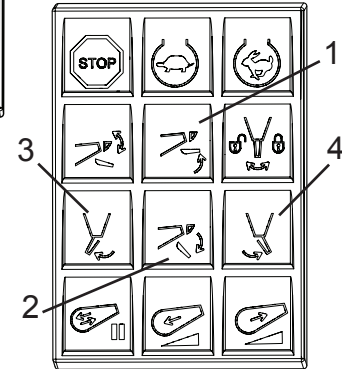

Figure 45

3.11 Hopper, Chute Lock, and Chute Operation with Wireless Transmitter (If Equipped)

Hopper Operation: Push the Hopper button to raise/lower air hopper (option) (Figure 46, Item 1).

Chute Lock: Push the Chute Lock button to lock/unlock air chute lock (Figure 46, Item 2).

Chute Lower: Push the Chute Lower button to lower the chute (Figure 46, Item 3).

Chute Raise: Push the Chute Raise button to raise chute (Figure 46, Item 4).

OPERATIONAL NOTE: Upon truck startup, cycle the Hopper button and the Chute LOCK button until “Hopper DOWN” and “Chute LOCK” icons are illuminated on the touch screen.

Wireless Transmitter

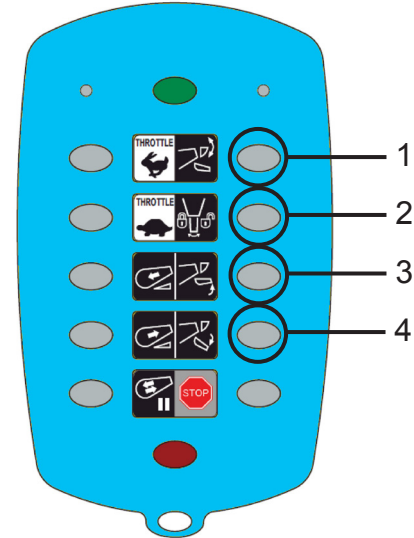

Figure 46

Operation

3.12 Work Lighting Functions

The standard in-cab keypad (Figure 47) is the only method for enabling or disabling the work lighting functions. The touch screen monitor only displays whether the work lighting is turned on or off.

- Press the keypad button to turn on or off the Strobe Lights, Perimeter Lights, and Work Lights.

Ref.	Function	Description
1	Strobe Lights	All locations of strobe lights.
2	Perimeter Lights	Fender mounted perimeter lights.
3	Work Lights	Rear pedestal work lights.

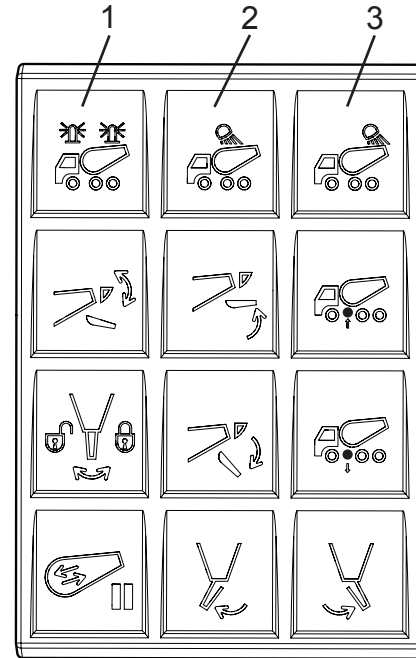

Figure 47

3.13 Bridgemaster Axle Operation

The touch screen monitor displays information necessary for safe operation of the Bridgemaster axle, although the keypad buttons are the only method to raise or lower the axle.

1. Check the status of the main chute by looking at the chute hazard indicator on the touch screen monitor AND through visual observation.
 - a. Center and lower chute as required. Make sure the chute “lowered and centered” icon appears on the top row of the monitor display (Figure 48, Item 1) before commanding the Bridgemaster axle up or down.
2. Prior to lowering the Bridgemaster, note the pressure requirements on the pressure data placard for the load being transported. **The axle pressure MUST match the load.**
 - b. Use the PRV2 adjusting knob on the Bridgemaster to dial in the proper pressure for the load being transported. The BM PSI gauge on the screen (Figure 48, Item 2) should change according to the pressure dialed in on the PRV2 adjusting knob.

NOTE: The Bridgemaster axle automatically raises when the truck is placed in reverse.

NOTE: An alarm buzzer will sound in the cab when the Bridgemaster axle is in motion (raising or lowering).

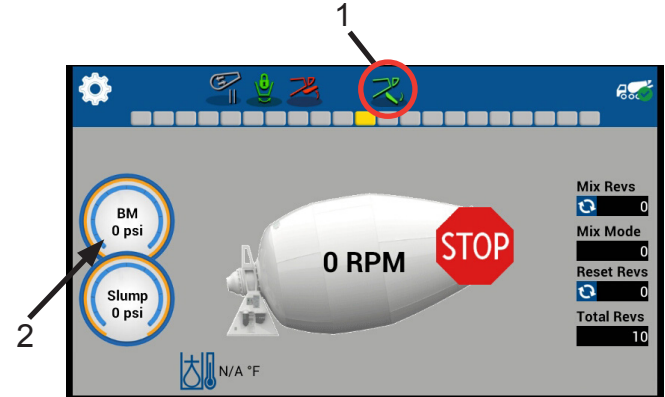

Figure 48

Operation

3.13.1 Operation Notes for Bridgemaster Axle

- The Bridgemaster axle must be raised anytime the drum is empty
- Initial operation of the Bridgemaster axle will not begin if the chute hazard indicator shows the chute off to the side or raised
- A Bridgemaster axle STOP button is on an in-cab keypad and is used to stop axle motion (Figure 49, Item 1). **NOTE:** The STOP button will also stop the chute raise/lower functions.
- The axle start/stop feature should only be used as such. It is not designed to be used as an on/off switch for the axle.

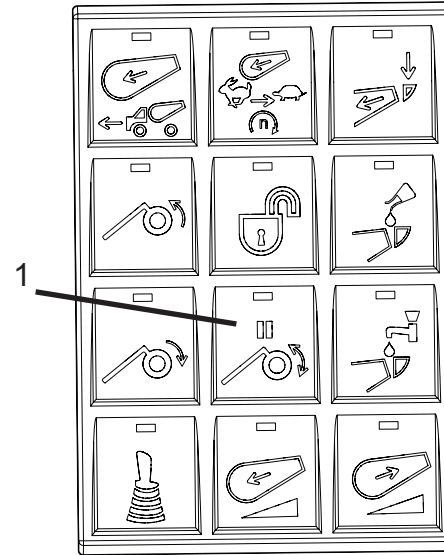

Figure 49

3.13.2 Bridgemaster Axle Service Brake Operation

The Bridgemaster axle service brakes work in conjunction with the chassis service brake system (all chassis models) and can be configured to also operate with the chassis parking brake system (option).

3.13.2.1 Normal Service Brake Operation (All Chassis Models)

- To engage the Bridgemaster axle service brakes under normal operation, depress the chassis treadle valve (brake pedal).
- To disengage the Bridgemaster axle service brakes under normal operation, release the chassis treadle valve (brake pedal).

3.13.2.2 Parking Service Brake Operation (Option)

- To engage the Bridgemaster axle service brakes with the chassis park brake, pull the chassis parking brake knob out.
- To disengage the Bridgemaster axle service brakes with the chassis park brake, push the chassis parking brake knob in.

3.13.3 Emergency Manual Bridgemaster Axle Operation

If the Bridgemaster axle controls fail, and there is still a need to raise or lower the Bridgemaster axle, the directional control valve can be operated manually.

3.13.3.1 Lowering the Bridgemaster Axle

WARNING

When operating the Bridgemaster® trailer:

- **Never lower and pressurize Bridgemaster trailer when the mixer drum is empty**
- **Do not coast backward while Bridgemaster trailer is down**
- **Do not exceed the maximum legal payload, or maximum GVWR or GAWR, whichever is less**
- **Always adjust pressure to the weight of the payload to be carried**
- **Always raise the Bridgemaster trailer before backing up**
- **Bridgemaster trailer must be raised when the truck leaves the roadway or regulated surfaces**
- **At the job site, use the lowest transmission gear, and proceed at low speed (5 mph [8.3 km/h]) to the discharge area**
- **Failure to follow all these steps may cause serious personal injury or equipment damage.**

NOTE

If in an emergency situation it becomes necessary to raise or lower the Bridgemaster® trailer manually, the following procedure should be performed by a competent mechanic only.

1. If possible, position the truck on a firm, level surface. Place the transmission in PARK or NEUTRAL, and engage the parking brake. Allow the engine to run at idle. (Refer to the Operator's Manual supplied by the chassis supplier for all parking procedures.)

⚠ WARNING

Make sure the area behind the truck is clear of people or obstructions before raising or lowering the Bridgemaster® trailer. The alarm in both the cab and at the rear of the mixer sounds when the trailer is traveling up or down. Keep clear of the area behind the truck and of the trailer pinch points while the trailer is in motion. Failure to follow all these steps may cause serious personal injury or equipment damage.

2. Place wheel chocks or blocks in front of and behind the truck's front wheels.
3. Check the amount of concrete loaded in the Mixer, and compare that information with the Bridgemaster axle information placard (Figure 50, Item 1). The information on the Bridgemaster® axle information placard will vary, depending on the truck configuration.

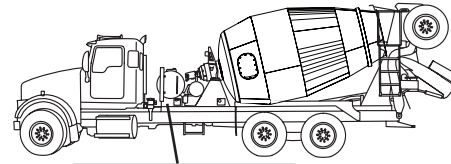

**BRIDGEMASTER® TRAILER
AND PUSHER AXLE MUST BE
UP WHEN EMPTY**

AXLE KPA/PSI SETTINGS

Meters	Yards	ALL AXLES UP
2.29	3	
3.06	4	
3.82	5	
4.59	6	
5.35	7	
6.12	8	
6.88	9	
7.65	10	
8.41	11	
9.18	12	

Set pushers at: KPA/PSI

780.214615

Figure 50

4. Once the pressure requirements have been determined, use the PRV knob (Figure 51, Item 1) to adjust the pressure to the required pressure. Pressure will be displayed on the gauge (Figure 51, Item 2).

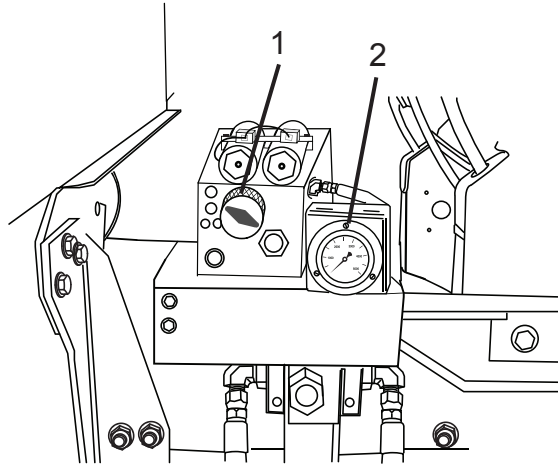

Figure 51

CAUTION

Make sure the fold-over chute is folded and the discharge chute is centered and lowered before raising or lowering the Bridgemaster® trailer. Failure to comply may cause damage to property or equipment.

WARNING

Crush Hazard. Make sure the area behind the truck is clear of people or obstructions before raising or lowering the Bridgemaster® trailer. The alarm in both the cab and at the rear of the mixer sounds when the trailer is traveling up or down. Keep clear of the area behind the truck and of the trailer pinch points while the trailer is in motion. Failure to comply may result in serious personal injury or death.

NOTE

The Bridgemaster manual overrides are intended for emergency use only. Valve location may vary, depending on truck configuration.

NOTE

The ends of the valve spools required to RAISE or LOWER and START and STOP may vary, depending on plumbing configurations.

NOTE

The valve spool pin is recessed in the valve end. Use of a tool may be required in order to manually shift the valve spool.

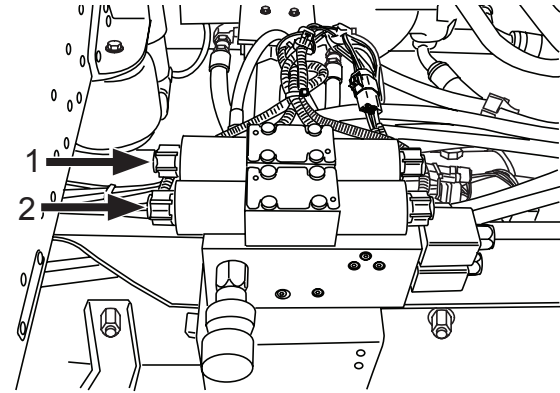

Figure 52

5. Manually fold the fold-over chute, and make sure the discharge chute is centered and lowered.
6. Locate and remove the end caps from the Bridgemaster directional control valves.
7. Manually shift the start/stop valve spool by pressing in on the end of the spool (Figure 52, Item 1).
8. Manually shift the raise/lower valve spool by pressing in on the end of the spool (Figure 52, Item 2).

9. Remove the wheel chocks or blocks from the front wheels before moving the trucks.
10. Once the truck is delivered to the repair shop and properly parked, remove the Mixer from service until repairs are completed.
11. Call Revolution Service at (855) 202-6491 if you have questions or need assistance.

3.13.3.2 Raising the Bridgemaster Axle

WARNING

When operating the Bridgemaster® trailer:

- Never lower and pressurize Bridgemaster trailer when the mixer drum is empty
- Do not coast backward while Bridgemaster trailer is down
- Do not exceed the maximum legal payload, or maximum GVWR or GAWR, whichever is less
- Always adjust pressure to the weight of the payload to be carried
- Always raise the Bridgemaster trailer before backing up
- Bridgemaster trailer must be raised when the truck leaves the roadway or regulated surfaces
- At the job site, use the lowest transmission gear, and proceed at low speed (5 mph [8.3 km/h]) to the discharge area

Failure to follow all these steps may cause serious personal injury or equipment damage.

NOTE

If in an emergency situation it becomes necessary to raise or lower the Bridgemaster® trailer manually, the following procedure should be performed by a competent mechanic only.

1. If possible, position the truck on a firm, level surface. Place the transmission in PARK or NEUTRAL, and engage the parking brake. Allow the engine to run at idle. (Refer to the Operator's Manual supplied by the chassis supplier for all parking procedures.)

WARNING

Crush Hazard. Make sure the area behind the truck is clear of people or obstructions before raising or lowering the Bridgemaster® trailer. The alarm in both the cab and at the rear of the mixer sounds when the trailer is traveling up or down. Keep clear of the area behind the truck and of the trailer pinch points while the trailer is in motion. Failure to comply may result in serious personal injury or death.

Operation

2. Place wheel chocks or blocks in front of and behind the truck's front wheels.

NOTE

The Bridgemaster® pressure gauge may be located near the Bridgemaster® valve, or in the truck cab, depending on the Mixer configuration.

3. Turn the PRV knob (Figure 53, Item 1) all the way counterclockwise to minimize the pressure applied to the Bridgemaster axle when the drum is empty. Pressure will be displayed on the gauge (Figure 53, Item 2).

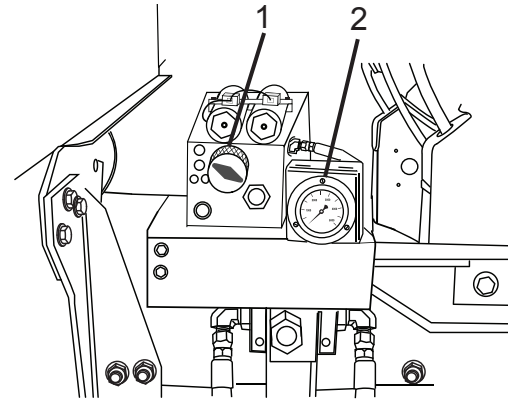

Figure 53

CAUTION

Make sure the fold-over chute is folded and the discharge chute is centered and lowered before raising or lowering the Bridgemaster® trailer. Failure to comply may cause damage to property or equipment.

4. Make sure the fold-over chute is folded, and the discharge chute is centered and lowered.
5. Locate and remove the end caps from the Bridgemaster directional control valves.

NOTE

The Bridgemaster manual overrides are intended for emergency use only. Valve location may vary, depending on truck configuration.

NOTE

The ends of the valve spools required to RAISE or LOWER and START and STOP may vary, depending on plumbing configurations.

NOTE

The valve spool pin is recessed in the valve end. Use of a tool may be required in order to manually shift the valve spool.

6. Manually shift the start/stop valve spool by pressing in on the end of the spool (Figure 54, Item 1).
7. Engage the Bridgemaster axle function by manually shifting the start/stop valve spool (Figure 54, Item 2).

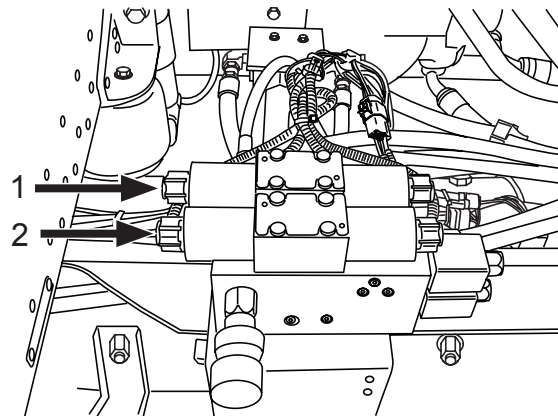

Figure 54

8. Remove the wheel chocks or blocks from the front wheels before moving the truck.
9. Once the truck is delivered to the repair shop and properly parked, remove the Mixer from service until repairs are completed.
10. Call Revolution Service at (855) 202-6491 if you have questions or need assistance.

4.0 Traditional Electronic Control System Instruments and Controls

If your Mixer is equipped with electronic controls (not touch screen controls), the following figures and tables identify and describe the electronic controls. These instructions include optional features that may or may not be included on your Mixer.

To make sure you understand proper operating procedures, read this section and carefully practice with the controls and instruments to learn how to safely operate the equipment.

4.1 EP Drum Control System

4.1.1 Maestro Revision E-10

Several enhancements were made to the EP Drum Control System with the implementation of Revision E-10 to the Maestro.

Some of the new enhancements are as follows:

- The Charge and Discharge inputs are disabled when the CONSTANT SPEED switch is ON
- Remains in Constant Speed mode after the CONSTANT SPEED switch is turned OFF until any of the START/STOP, CHARGE OR DISCHARGE

switches are pressed

- A dual ramp rate is utilized that enables a faster ramping rate to be used after the CHARGE or DISCHARGE switch is pressed and held for more than 1 second
- Drum speed is limited to 18 RPM
- A 50 Hz dither signal is incorporated to enhance response

4.1.2 How to Identify Revision E-10

An electronic module (Maestro) is located in the control fuse box. Maestros that are programmed with the enhancements of Revision E-10 can be identified by a label on the Maestro. The label will include the identifier number, followed by a letter that reflects the revision level (in this case revision "B") (Figure 55, Item 1). The Revolution part number 1109192 (Figure 55, Item 2), for the Maestro with Revision E-10 programming, is also identified.

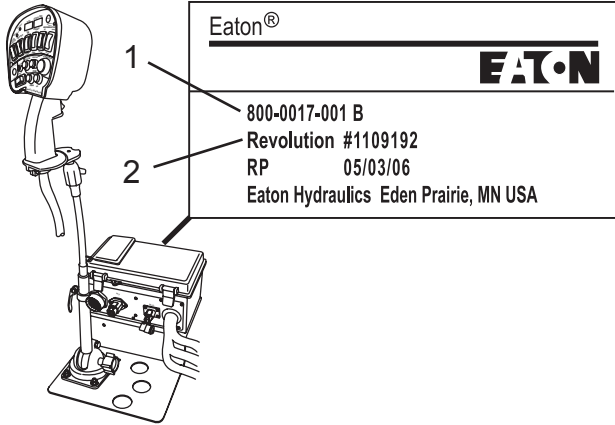

Figure 55

Operation

4.2 Electronic Cab Controls - Cab Control Pendant

The in-cab controls consist of a control pendant (Figure 56, Item 1), a control fuse panel (Figure 56, Item 2) in a fuse box (Figure 56, Item 3), and a jumper plug (Figure 56, Item 4).

No.	Item	Description
1	Control Pendant	Controls Drum, Chute, and Accessory Functions. Contains various indicator lights and displays.
2	Fuse Panel	Contains fuses for the mixer function electrical circuits.
3	Control Fuse Box	Contains fuses for the mixer function electrical circuits. The Control Fuse Box also includes a connector and jumper that are used to place the Mixer in the TRANSPORT or NORMAL operation modes.
4	Jumper Plug	The jumper plug is used to place the Mixer in either the TRANSPORT or NORMAL operation modes.

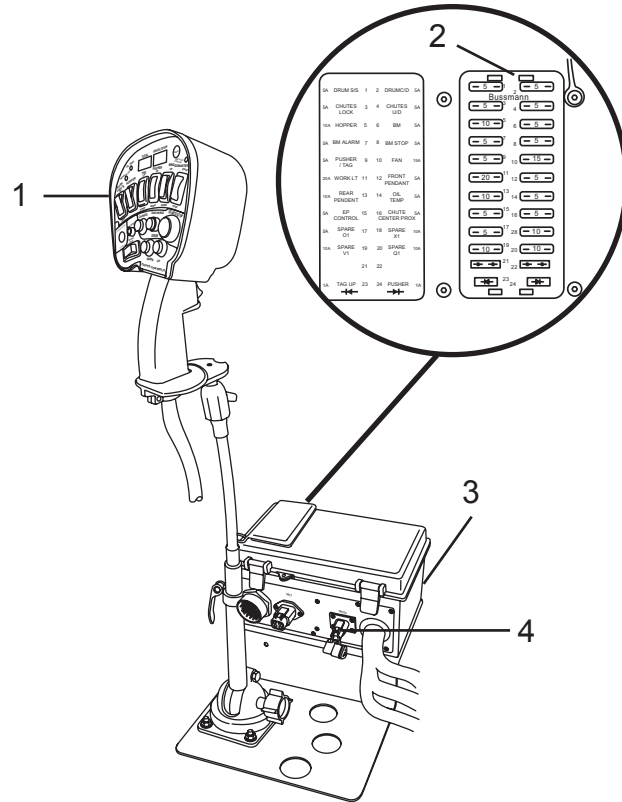

Figure 56

4.2.1 Electronic Cab Control Rocker Switch Functions

Accessories and mixer functions and some options are operated by switches on the control pendant (Figure 57 and Figure 58). The actual switches present on the control pendant will vary, depending on the configuration of your Mixer.

No.	Item	Operation
1	WATER Rocker Switch	Press the switch to inject water into the mixer drum. (See Remote Water Injection System for more information.)
2	CHUTE SWING Rocker Switch	Press the top of the switch to move the discharge chute to the right. Press the bottom of the switch to move the discharge chute to the left.
3	PUSHER Rocker Switch (OPTIONAL)	Select DOWN to lower the pusher axle(s). ¹ Select UP to raise the pusher axle(s).

No.	Item	Operation
4	DISCHARGE Switch	Activates drum rotation in discharge (CCW) direction. Also increases drum speed in discharge (CCW) direction or decreases drum speed in charge (CW) direction.
5	BRIDGEMASTER UP/DOWN Rocker Switch	Press to select the raise or lower mode. ²
6	BRIDGEMASTER START/STOP Rocker Switch	Press START to engage the Bridgemaster functions. Press STOP to disengage Bridgemaster functions.
7	START/STOP Switch	Press the switch to start and stop drum functions.
8	CHUTE UP Switch	Press and hold the switch to raise the discharge chute.
9	CHUTE DOWN Switch	Press and hold the switch to lower the discharge chute.

Operation

No.	Item	Operation
10	CHARGE Switch	Activates drum rotation in charge (CW) direction. Also increases drum speed in charge (CW) direction or decreases drum speed in discharge (CCW) direction.
11	CHUTE LOCK Rocker Switch	Press the switch to engage the chute air lock function. ³
12	CONSTANT SPEED Switch	Activates drum rotation at a constant speed in the charge (CW) direction.
13	WORK LIGHTS Rocker Switch	Select ON to activate the work lights. Select OFF to deactivate the work lights.
14	HOPPER Rocker Switch	Press the switch to swing the air flip-up charge hopper up or down. ³
15	BRIDGEMASTER ACTIVATE Switch	Press and hold while selecting the UP or DOWN function on the BRIDGEMASTER UP/DOWN switch.

¹ The pusher axle(s) will automatically raise when the truck is placed in reverse. (See Pusher Axles.)

² Before raising or lowering the Bridgemaster axle, make sure all preconditions have been met. (See Lowering the Bridgemaster Axle.)

³ The function triggered by the switch will depend on the current state of that device. (Example: If the charge hopper is up, activating the switch will lower it.)

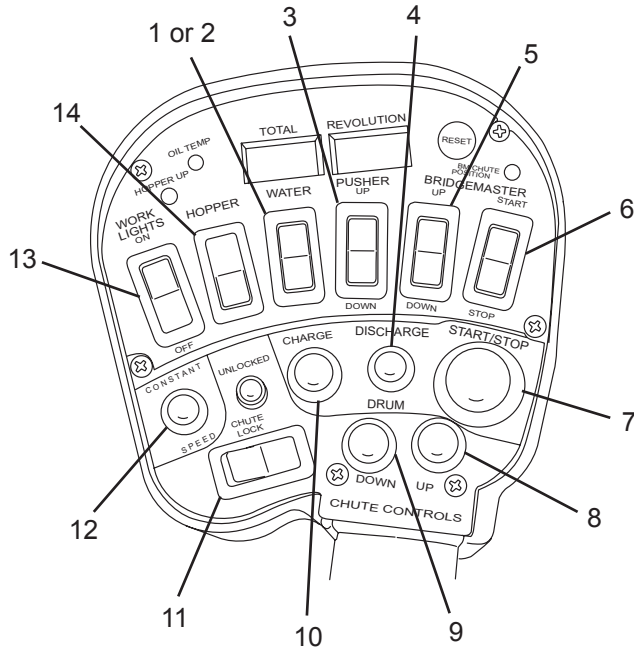

Figure 57

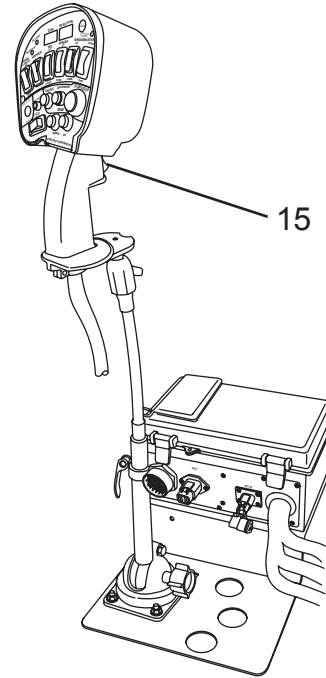

Figure 58

Operation

4.2.2 Indicator Light and Display Functions

The indicator lights and displays (Figure 59) are used to display the status of various functions. The actual indicator lights present on the control pendant will vary, depending on the configuration of your Mixer.

No.	Item	Operation
1	HOPPER UP Indicator Light	Light indicates when the charge hopper is in the raised position.
2	OIL TEMP Indicator Light	Light indicates when the hydraulic oil reaches 215°F (102°C).
3	TOTAL Display	Indicates the total number of drum revolutions. Counter cannot be reset.
4	REVOLUTION Counter Display	Indicates the number of drum revolutions. Counter can be reset.
5	RESET Button	Press to reset the REVOLUTION counter display.
6	BM/CHUTE POSITION Indicator Light	Indicates when the chute is correctly positioned to allow raising or lowering of the Bridgemaster axle (chute is centered).

No.	Item	Operation
7	DISCHARGE Indicator Light	Indicates when the drum is rotating in the discharge direction. Also used for fault code diagnostics.
8	CHUTE LOCK Indicator Light (OPTIONAL)	Indicates when the main chute air lock is unlocked.
9	CONSTANT SPEED Indicator Light (OPTIONAL)	Indicates when the CONSTANT SPEED function is enabled.

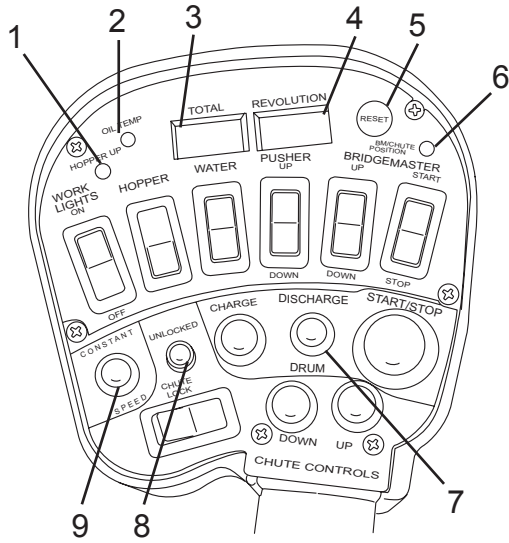

Figure 59

4.3.1 Electronic Cab Control Rocker Switch Functions

Accessories and mixer functions and some options are operated by rocker switches on the top of the control box (Figure 61). The actual switches present in the control box will vary depending on the configuration of your Mixer.

No.	Control	Normal Use or Reading
1	DRUM CHARGE/ DISCHARGE Rocker Switch	<p>Press the CHARGE side of the switch to activate the drum rotation in CHARGE (CW) direction. Holding the switch down also increases drum speed in CHARGE (CW) direction or decreases drum speed in DISCHARGE (CCW) direction.</p> <p>Press the DISCHARGE side of the switch to activate the drum rotation in DISCHARGE (CCW) direction. Holding the switch down also increases drum speed in DISCHARGE (CCW) direction or decreases drum speed in CHARGE (CW) direction.</p>

Operation

No.	Control	Normal Use or Reading
2	CHUTE UP/ DOWN Rocker Switch	Select UP to raise the discharge chute. Select DOWN to lower the discharge chute.
3	CHUTE SWING Rocker Switch (OPTIONAL)	Press and hold the right side of the switch to move the chute to the right. Press and hold the left side of the switch to move the chute to the left.
4	PUSHER Rocker Switch (OPTIONAL)	Select DOWN to lower the pusher axle(s). Select UP to raise the pusher axle(s). ¹
5	BRIDGEMASTER ACTIVATE Rocker Switch	Press and hold while selecting the UP or DOWN function on the BRIDGEMASTER UP/DOWN switch.
6	BRIDGEMASTER UP/DOWN Rocker Switch	Press to select the raise or lower mode.

No.	Control	Normal Use or Reading
7	BRIDGEMASTER START/STOP Rocker Switch	Press START to engage the Bridgemaster functions. Press STOP to disengage the Bridgemaster functions.
8	ADD WATER Rocker Switch (OPTIONAL)	Press the switch to inject water into the mixer drum. (See Remote Water Injection System.)
9	WORK LIGHT Rocker Switch (OPTIONAL)	Select ON to activate the work lights. Select OFF to deactivate the work lights.
10	HOPPER Rocker Switch (OPTIONAL)	Press the switch to swing the air flip-up hopper up or down. ²
11	CHUTE LOCK Rocker Switch (OPTIONAL)	Press the right side of the switch to engage or disengage the chute air lock.

No.	Control	Normal Use or Reading
12	CONSTANT SPEED Rocker Switch (OPTIONAL)	<p>Press the right side of the switch to activate drum rotation at a constant speed in the charge direction (CW).</p> <p>Press the left side of the switch to deactivate the constant speed function.</p>
13	DRUM S/S (Start/Stop) Rocker Switch (OPTIONAL)	<p>Press the switch to start or stop drum functions. ¹</p>

¹ The pusher axle(s) will automatically raise when the truck is placed in reverse. (See Pusher Axles.)

² The function triggered by the switch will depend on the current state of that function. (Example: If the charge hopper is up, activating the switch will lower it.)

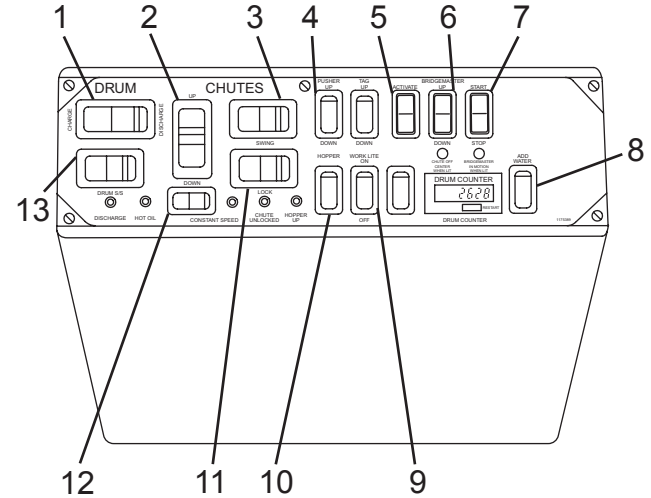

Figure 61

Operation

4.3.2 Indicator Light and Display Functions

The indicator lights and displays (Figure 62) are used to display the status of various functions. The actual indicator lights present in the control box will vary depending on the configuration of your Mixer.

No.	Item	Normal Use or Reading
1	CHUTE OFF CENTER when lit	Light indicates when the discharge chute is off the center position.
2	BRIDGEMASTER IN MOTION when lit	Light indicates when the Bridgemaster axle is being raised or lowered. The indicator light will go off when the axle is either fully raised and latched or fully lowered.
3	DRUM COUNTER Display	Counts the number of revolutions of the mixer drum in either direction. Push the button to reset.

No.	Item	Normal Use or Reading
4	HOPPER UP Indicator Light (OPTIONAL)	Light indicates when the charge hopper is in the raised position.
5	CHUTE UNLOCKED Indicator Light (OPTIONAL)	Light indicates when the discharge chute is unlocked.
6	CONSTANT SPEED Indicator Light (OPTIONAL)	Indicates when the CONSTANT SPEED function is enabled.
7	HOT OIL Indicator Light (OPTIONAL)	Light indicates when the hydraulic oil reaches 215°F (102°C).
8	DISCHARGE Indicator Light (OPTIONAL)	Indicates when the drum is rotating in the DISCHARGE direction. Also used for fault code diagnostics.

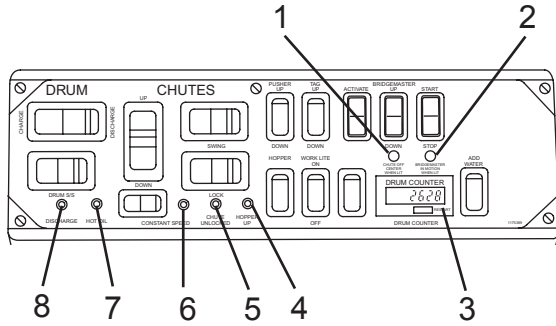

Figure 62

Operation

4.4 Electronic Outside Controls

The outside controls consist of a rear pendant (Figure 63, Item 1) and a manual chute lock (Figure 63, Item 2).

No.	Item	Description
1	Rear Control Pendant	Contains toggle switches to control various mixer functions. The controls contained will vary depending on options.
2	Manual Chute Lock	Mechanically locks the discharge chute in one of several positions.

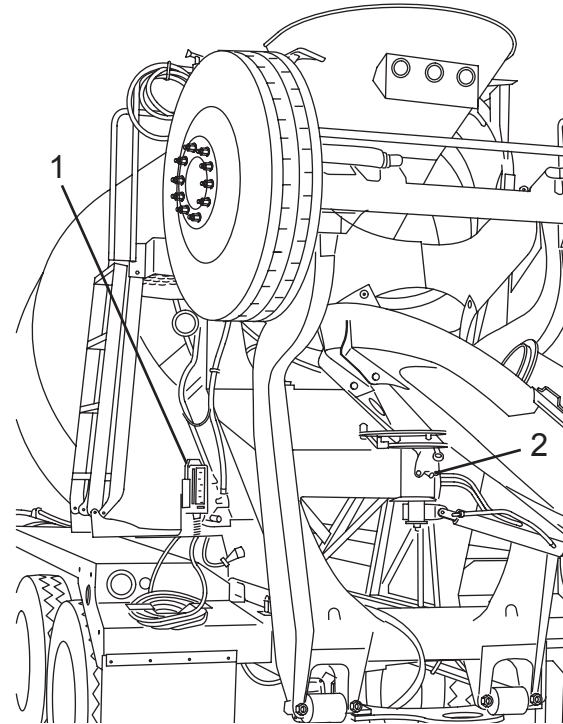

Figure 63

4.4.1 Electronic Rear Pendant Controls

The rear pendant (Figure 64) toggle switches to control various mixer functions. The actual switches present in the rear pendant will vary depending on the configuration of your Mixer. The operator can take the rear pendant up the ladder platform for quick access to starting and stopping the drum.

No.	Control	Normal Use or Reading
1	THROTTLE Toggle Switch (OPTIONAL) ¹	Push and hold the switch to the right to increase the engine speed. Push and hold the switch to the left to decrease the engine speed. (See Adjusting the Throttle Speed.)
2	HOPPER Toggle Switch (OPTIONAL) ²	Push the switch to move the hopper up or down. If the pendant is equipped with the chute swing option, the HOPPER switch will be moved from the pendant to the rear pedestal.

No.	Control	Normal Use or Reading
3	CHUTE SWING Toggle Switch (OPTIONAL)	Push the switch to the right to swing the chute to the right. Push the switch to the left to swing the chute to the left.
4	CHUTE LOCK Toggle Switch (OPTIONAL) ²	Push the switch to activate or deactivate the discharge chute air lock.
5	CHUTE UP/ DOWN Toggle Switch	Push and hold the switch to the right to raise the discharge chute. Push and hold the switch to the left to lower the discharge chute.
6	DRUM CHARGE/ DISCHARGE Toggle Switch (OPTIONAL)	Activates drum rotation in charge (CW) and discharge (CCW) directions. Also increases and decreases drum speed in charge and discharge directions.
7	DRUM S/S Toggle Switch (OPTIONAL) ²	Starts and stops drum functions.

Operation

¹ The chassis cruise control must be in the ON position, the parking brake must be applied, and the automatic transmission must be in NEUTRAL.

² The function triggered by the switch will depend on the current state of that function. (Example: If the charge hopper is up, activating the switch will lower it.)

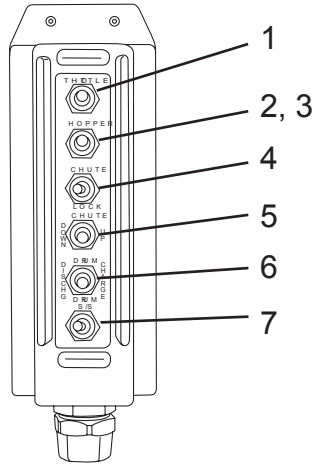

Figure 64

1. Turn truck ignition switch OFF. (Refer to the Operator's Manual supplied by the chassis supplier for all shut-down and parking procedures.)
2. Disconnect the rear pendant harness connector (Figure 65, Item 2) from the rear pedestal.
3. Install a jumper plug (Figure 65, Item 3) into the rear pendant harness connector. Purchase the jumper plug from www.streetsmartparts.com or by calling Revolution Parts at (855) 202-6491.
4. Start the truck.
5. Operate the mixer functions using the cab control box.

4.4.1.1 By-Passing the Rear Pendant

If the rear pendant (Figure 65, Item 1) is lost, or becomes damaged or faulty, a jumper plug (Figure 65, Item 3) must be installed in the rear pendant socket to allow operation of control functions from the cab control box.

Contact Revolution Parts and Support at (855) 202-6491 for jumper plug part numbers.

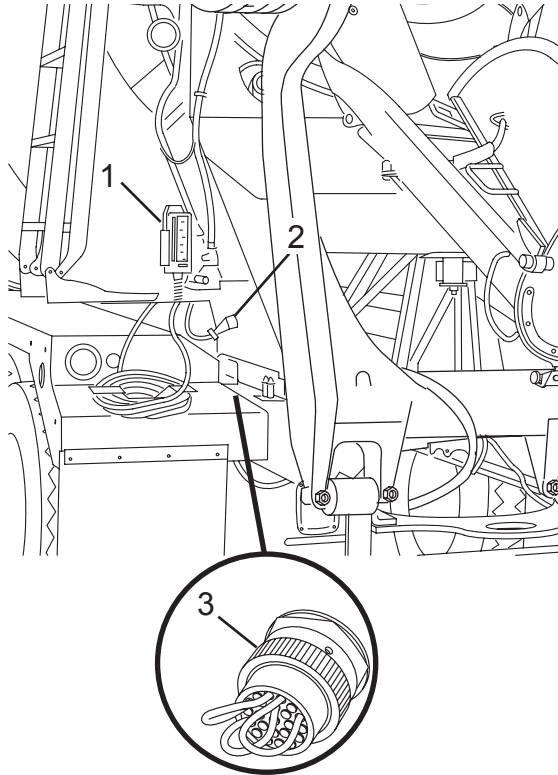

Figure 65

Operation

4.4.2 Manual Chute Lock

CAUTION

Do not move the vehicle without locking the chute with the manual chute lock. Do not use the chute air lock to secure the chute for transport. Failure to comply may cause damage to property or equipment.

The manual chute lock mechanically locks the chute in one of several predetermined positions.

To move the chute:

1. Unlock the chute air lock (if equipped).
2. While holding the chute, pull down on the lever (Figure 66, Item 1) and move it to the right or left until the lever is seated in one of the lock positions.
3. Move the main chute (Figure 66, Item 2) to the desired position, and while holding the chute, move the lever to the center. Make sure the lever pin is fully seated into one of the holes in the chute plate before releasing the chute. Move the main chute from side to side as needed to align the pin and hole.

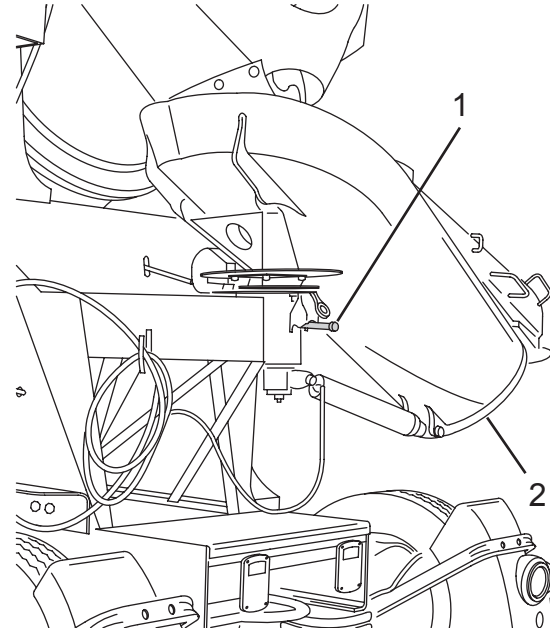

Figure 66

4.5 Electronic Control Fuse Functions

If a function in the cab pendant controls or rear pendant controls does not operate, check the condition of the fuses (Figure 67) located in the cover of the control fuse box (in the cab control pendant) or the rear of the control box (cab control box). A label is located beside the fuses to identify the functions they control.



CAUTION

Do not replace a fuse with a higher amperage fuse than is listed for the location. Always use new fuses of the correct amperage. Failure to comply may cause damage to property or equipment.

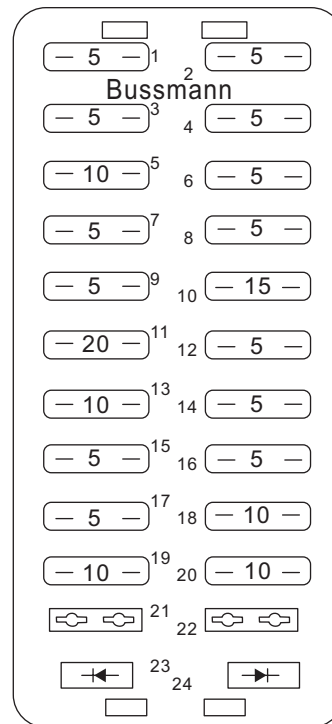

Figure 67

Operation

Fuse No.	Amperage Rating	Description
1	5 amp	DRUM S/S (Start/Stop) (OPTIONAL)
2	5 amp	DRUM C/D (Charge/ Discharge)
3	5 amp	CHUTE LOCK (OPTIONAL)
4	5 amp	CHUTE U/D (Up/Down)
5	10 amp	HOPPER (OPTIONAL)
6	5 amp	BM
7	5 amp	BM ALARM
8	5 amp	BM STOP
9	5 amp	PUSHER (OPTIONAL)
10	15 amp	FAN
11	20 amp	WORK LIGHT (OPTIONAL)
12	5 amp	FRONT PENDANT (Cab Control Box)
13	10 amp	REAR PENDANT
14	5 amp	OIL TEMP
15	5 amp	Not Used
16	5 amp	Not Used

Fuse No.	Amperage Rating	Description
17	5 amp	Spare Power 01
18	10 amp	Spare Power X1
19	10 amp	Spare Power V1
20	10 amp	Spare Power Q1
21	N/A	Not Used
22	N/A	Not Used
23	N/A	Tag Up Diode (IF EQUIPPED)
24	N/A	Pusher Up Diode

4.6 Fault Display - EP and RE Controls

4.6.1 Fault Codes

If the drum control system is not functioning as expected, fault codes can be displayed by a series of flashes on the DISCHARGE light. Fault codes will not be viewable until a special switch sequence is entered on the cab pendant.

To view the fault codes:

1. Press the START/STOP switch (Figure 68, Item 1) to stop drum rotation. Within 10 seconds, press and hold the CHARGE switch (Figure 68, Item 4) for at least five seconds, then release the CHARGE switch.
2. Press and hold the DISCHARGE switch (Figure 68, Item 3) for at least five seconds, then release the DISCHARGE switch. The DISCHARGE light (Figure 68, Item 2) will flash the fault code or will be lit with no flashing. If the DISCHARGE light is ON and does not flash, there is no fault.
3. Press the START/STOP switch to turn the DISCHARGE light OFF.

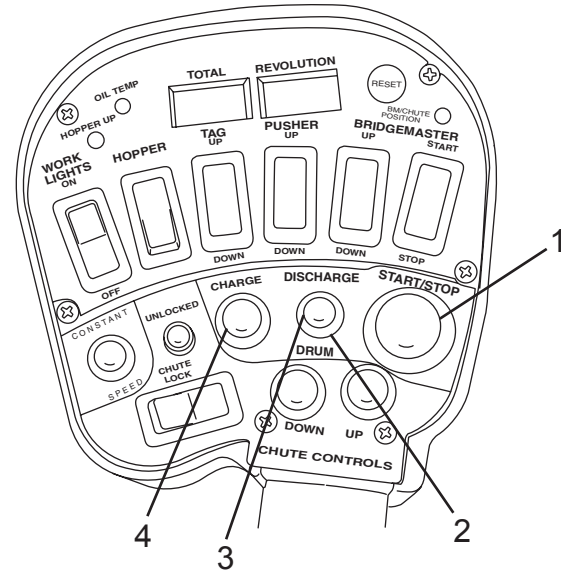

Figure 68

The flashing DISCHARGE light indicates one of the following faults:

- **ONE flash and then a two-second pause (repeating). The charge solenoid coil, connector, or wiring is open or shorted.**

Operation

- **TWO flashes and then a two-second pause (repeating). The discharge solenoid coil, connector, or wiring is open or shorted.**
- **THREE flashes and then a two-second pause (repeating). The drum speed sensor on the motor is not functioning.**
- **FOUR flashes and then a two-second pause (repeating). The drum is not rotating in the command direction, the EP Control is not wired properly, or the hydraulic motor is not plumbed properly.**

To clear a fault code that is being viewed, Press the CHARGE switch for more than five seconds, then press the DISCHARGE switch for more than five seconds. The DISCHARGE light will be lit solid (no flashing) to indicate that the fault code has been cleared. Press the START/STOP switch to turn the DISCHARGE light OFF.

4.7 Drum Control Checkout Procedure

Only one fault code is reported at a time, even though multiple faults may have occurred. To verify that the problem has been corrected, maintenance should clear the fault code and run the following test.

1. Rotate the drum in the CHARGE (CW) direction at 3 to 5 RPM for 20 seconds.
2. Rotate the drum in the DISCHARGE direction at 3 to 5 RPM for 20 seconds.
3. Rotate the drum in Constant Speed for 20 seconds.

4.8 Add Water Function (If Equipped)

4.8.1 Manual Water Injection System

Water can be added to the drum by opening the water injection ball valve (Figure 69, Item 1) located at the rear of the Mixer.

Some Mixers may be equipped with an optional valve (Figure 69, Item 3). This valve will automatically close when the handle is released.

WARNING

Never allow the water from the tank to drain onto a public sidewalk or roadway. Water may cause the sidewalk or roadway to become slippery. Always drain the water system at a location designated by the job site manager or in compliance with your company policy. Failure to comply may result in serious personal injury or death.

Both valves may be equipped with a drain option. This feature automatically drains the water from the hose(s) beyond the valve, through a small hole at the rear of the valve (Figure 69, Item 2).

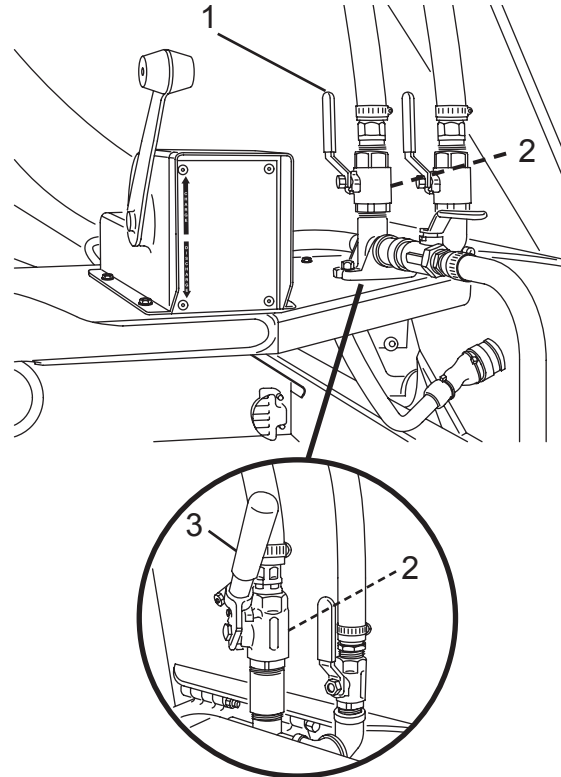

Figure 69

Operation

4.8.2 Remote Water Injection System

This system allows the operator to add water while remaining in the cab by activating the ADD WATER switch on the cab control box. (See “Rocker Switch Functions” for more information.)

To add water:

1. Open the water injection ball valve (Figure 70, Item 1).

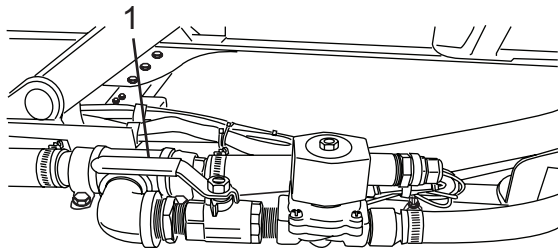

Figure 70

2. Press and hold the ADD WATER rocker switch on the cab control box to activate the system. (See “Rocker Switch Functions” for more information.)
3. Release the rocker switch when the desired amount of water has been added. (If equipped with a water meter, see “Water Meter Function (OPTIONAL)”.)
4. Close the water injection ball valve (Figure 70, Item 1).

5.0 Traditional Cable Control System Instruments and Controls

5.1 Cable Cab Controls

The in-cab controls are located on the mixer console between the seats (Figure 71).

The control box contains rocker switches, displays for the various mixer functions, lights, and options. The control box also contains a fuse panel.

No.	Position	Normal Use or Reading
1	Fuse Panel	Contains fuses for the mixer function electrical circuits.
2	Control Box	Controls drum, chute, and accessory functions. Contains various indicator lights and displays.
3	Drum Control Lever (CHARGE/DISCHARGE)	Controls the drum rotation direction and speed.

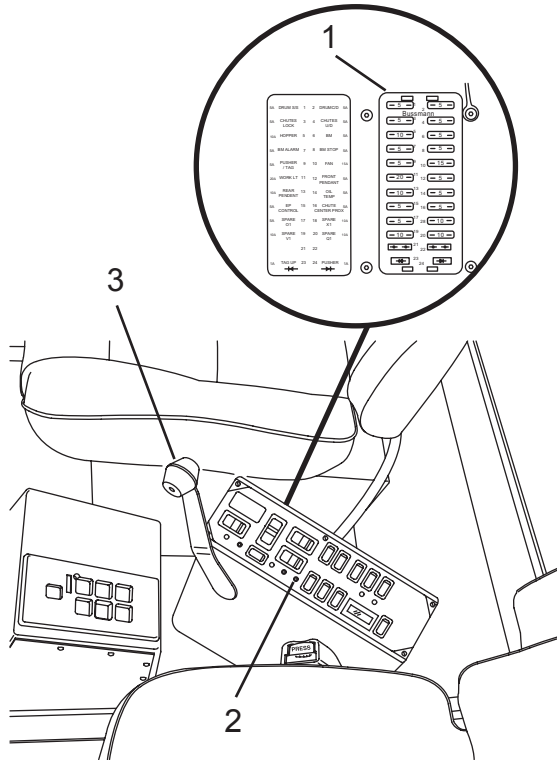

Figure 71

5.1.1 Cable Control Rocker Switch Functions

Accessories and mixer functions and some options are operated by rocker switches on the top of the control box (Figure 72). The actual switches present in the control box will vary, depending on the configuration of your Mixer.

No.	Item	Description
1	DRUM START/ STOP Rocker Switch	Press the switch to start or stop drum functions. ¹
2	CHUTE UP/ DOWN Rocker Switch	Select UP to raise the main chute. Select DOWN to lower the main chute.
3	CHUTE SWING Rocker Switch (OPTIONAL)	Press and hold the right side of the switch to move the chute to the right. Press and hold the left side of the switch to move the chute to the left.
4	PUSHER Rocker Switch (OPTIONAL)	Select DOWN to lower the pusher axle(s). Select UP to raise the pusher axle(s). ²

Operation

No.	Item	Description
5	BRIDGEMASTER ACTIVATE Rocker Switch	Press and hold while selecting the UP or DOWN function on the BRIDGEMASTER UP/DOWN switch.
6	BRIDGEMASTER UP/DOWN Rocker Switch	Press to select the raise or lower mode. ³
7	BRIDGEMASTER START/STOP Rocker Switch (OPTIONAL)	Press START to engage the Bridgemaster functions. Press STOP to disengage the Bridgemaster functions.
8	ADD WATER Rocker Switch (OPTIONAL)	Press the switch to add water to the concrete mix in the drum. (See Remote Water Injection System for more information.)
9	WORK LIGHT Rocker Switch (OPTIONAL)	Select ON to activate the work lights. Select OFF to deactivate the work lights.

No.	Item	Description
10	HOPPER Rocker Switch (OPTIONAL)	Press the switch to swing the air flip-up hopper up or down.
11	CHUTE LOCK Rocker Switch (OPTIONAL)	Press the switch to engage or disengage the chute air lock.

¹ The function triggered by the switch will depend on the current state of that device. (Example: If the charge hopper is up, activating the switch will lower it.)

² The pusher axle(s) will automatically raise when the truck is placed in reverse. (See Pusher Axles.)

³ Before raising or lowering the Bridgemaster axle, make sure all preconditions have been met. (See Lowering the Bridgemaster Axle for more information.)

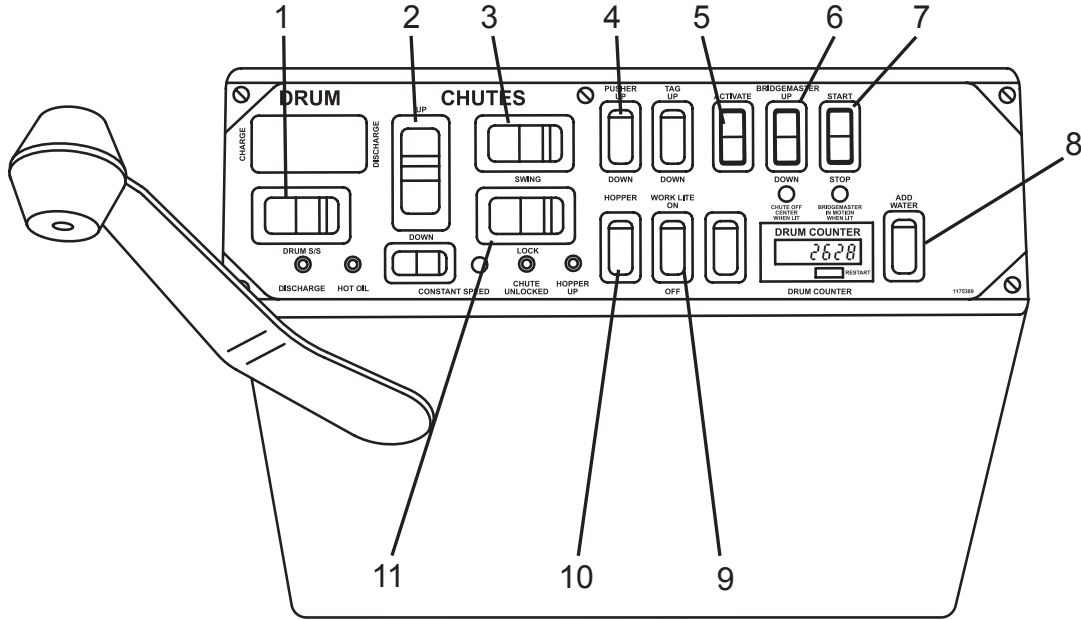

Figure 72

Operation

5.1.2 Indicator Light and Display Functions

The indicator lights and displays (Figure 73) are used to display the status of various functions. The actual indicator lights present in the control box will vary, depending on the configuration of your Mixer.

No.	Item	Operation
1	HOT OIL Indicator Light	Light indicates when the hydraulic oil reaches 215°F (102°C).
2	CHUTE OFF CENTER WHEN LIT Indicator Light	Light indicated when the discharge chute is off the center position.
3	BRIDGEMASTER IN MOTION WHEN LIT	Light indicates when the Bridgemaster axle is being raised or lowered. The indicator light will go off when the axle is either fully raised or latched, or fully lowered.
4	DRUM COUNTER Display	Counts the number of revolutions of the mixer drum in either direction. Push the button to reset.

No.	Item	Operation
5	HOPPER UP Indicator Light (OPTIONAL)	Light indicates when the flip-up charge hopper is in the raised position.
6	CHUTE UNLOCKED Indicator Light (OPTIONAL)	Light indicates when the main chute is unlocked.

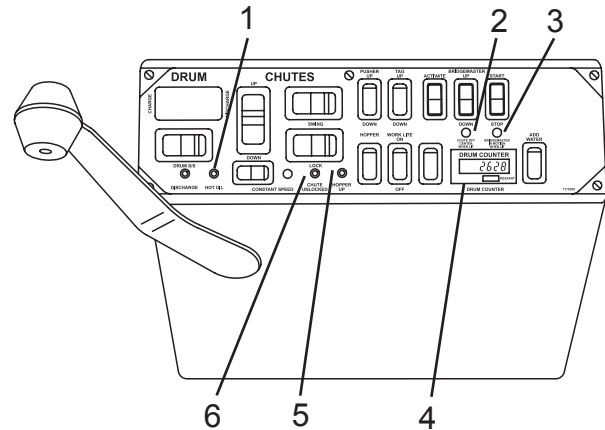

Figure 73

5.2 Cable Outside Controls

The outside controls consist of an optional rear pendant (Figure 74, Item 1), a manual chute lock (Figure 74, Item 2), and drum cable control (Figure 74, Item 3).

No.	Item	Description
1	Rear Control Pendant	Contains toggle switches to control various mixer functions. The controls contained will vary, depending on options.
2	Manual Chute Lock	Mechanically locks the main chute in one of several positions.
3	Drum Control	Contains the drum control lever that controls the speed and direction of the drum rotation. Early models may also contain toggle switches to control various mixer functions. The controls contained will vary, depending on options.

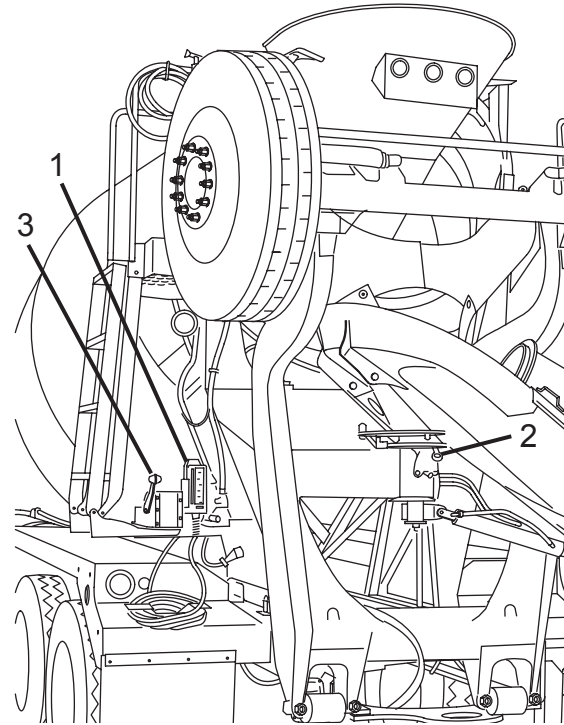

Figure 74

Operation

5.2.1 Cable Rear Control Pendant

The rear pendant (Figure 75) contains toggle switches to control various mixer functions. The actual switches present in the rear pendant will vary, depending on the configuration of your Mixer.

No.	Control	Normal Use or Reading
1	THROTTLE Toggle Switch (OPTIONAL)	Push to increase or decrease throttle speed. (See Adjusting the Throttle Speed for more information.) ¹
2	HOPPER Toggle Switch (OPTIONAL)	Push the switch to move the flip-up charge hopper up or down. ²
3	CHUTE LOCK Toggle Switch (OPTIONAL)	Push the switch to activate or deactivate the main chute air lock. ²
4	CHUTE UP/ DOWN Toggle Switch	Push and hold the switch to the right to raise the main chute. Push and hold the switch to the left to lower the main chute.

No.	Control	Normal Use or Reading
5	CHUTE SWING Toggle Switch (OPTIONAL)	Push the switch to the right to swing the chute to the right. Push the switch to the left to swing the chute to the left.
6	DRUM S/S (START/STOP) Toggle Switch	Push the switch to start or stop drum functions.

¹ The chassis cruise control must be in the ON position, the parking brake must be applied, and the automatic transmission must be in NEUTRAL.

² The function triggered by the switch will depend on the current state of that function. (Example: If the charge hopper is up, activating the switch will lower it.)

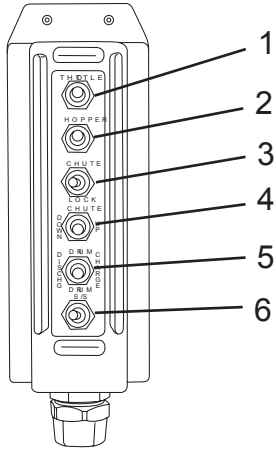

Figure 75

Operation

5.2.1.1 By-Passing the Rear Pendant

If the rear pendant (Figure 76, Item 1) is lost, or becomes damaged or faulty, a jumper plug (Figure 76, Item 3) must be installed in the rear pendant socket (Figure 76, Item 2) to allow operation of control functions from the cab control box.

Contact Revolution Parts and Support at (888) 209-6497 for jumper plug part numbers.

1. Turn truck ignition switch OFF. (Refer to the Operator's Manual supplied by the chassis supplier for all shut-down and parking procedures.)
2. Disconnect the rear pendant harness connector (Figure 76, Item 2) from the rear pedestal.
3. Install a jumper plug (Figure 76, Item 3) into the rear pendant harness connector. Purchase the jumper plug by calling Revolution Parts at (888) 209-6497.
4. Start the truck.
5. Operate the mixer functions using the cab control box.

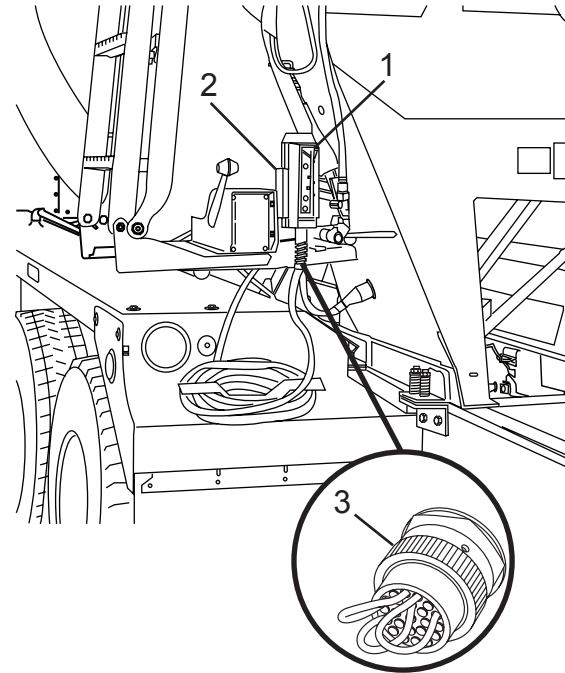

Figure 76

5.2.2 Cable Rear Drum Control

The rear drum control (Figure 77) and toggle switches control various mixer functions.

No.	Control	Normal Use or Reading
1	DRUM CONTROL LEVER (CHARGE/DISCHARGE)	Starting at the NEUTRAL position, pushing the lever forward (away from the operator) starts the drum rotating in the CHARGE direction. The farther the lever is pushed forward, the faster the drum rotates. Pulling the lever back (toward the operator) will decrease the drum speed until the NEUTRAL position is reached at which point the drum stops rotating. From the NEUTRAL position, pulling lever back (toward the operator) will start the drum rotating in the DISCHARGE direction. The farther the lever is pulled back, the faster the drum rotates.
2	HOPPER Toggle Switch (OPTIONAL)	Push the switch to move the flip-up charge hopper up or down. ¹

Operation

No.	Control	Normal Use or Reading
3	CHUTE LOCK Toggle Switch (OPTIONAL)	Push the switch to activate or deactivate the main chute air lock. ¹
4	THROTTLE Toggle Switch (OPTIONAL)	Push to increase or decrease throttle speed. (See Adjusting the Throttle Speed for more information.)
5	DRUM S/S (START/STOP) Toggle Switch	Push the switch to start or stop drum functions.
6	CHUTE UP/ DOWN Toggle Switch	Push and hold the switch to the UP position to raise the main chute. Push and hold the switch to the DOWN to lower the main chute.

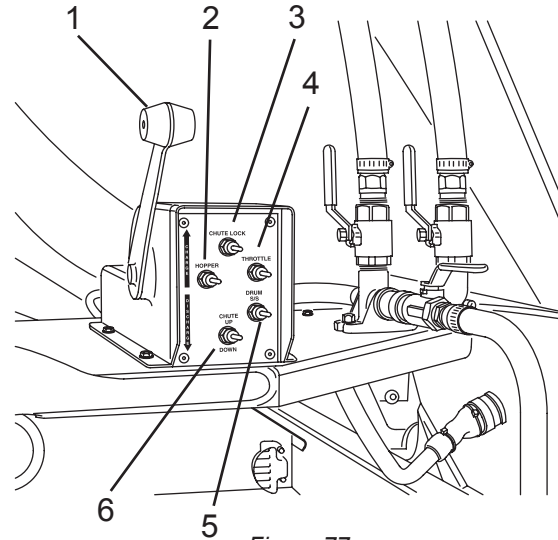

Figure 77

¹. The function triggered by the switch will depend on the current state of that function. (Example: If the charge hopper is up, activating the switch will lower it.)

². The chassis cruise control must be in the ON position, the parking brake must be applied, and the automatic transmission must be in NEUTRAL.

5.2.3 Manual Chute Lock

⚠ CAUTION

Do not move the vehicle without locking the chute with the manual chute lock. Do not use the chute air lock to secure the chute for transport. Failure to comply may cause damage to property or equipment.

The manual chute lock mechanically locks the chute in one of several predetermined positions.

To move the chute:

1. Unlock the chute air lock (if equipped).
2. While holding the chute, pull down on the lever (Figure 78, Item 1) and move it to the right or left until the lever is seated in one of the lock positions.
3. Move the main chute (Figure 78, Item 2) to the desired position, and while holding the chute, move the lever to the center. Make sure the lever pin is fully seated into one of the holes in the chute plate before releasing the chute. Move the chute from side to side as needed to align the pin and hole.

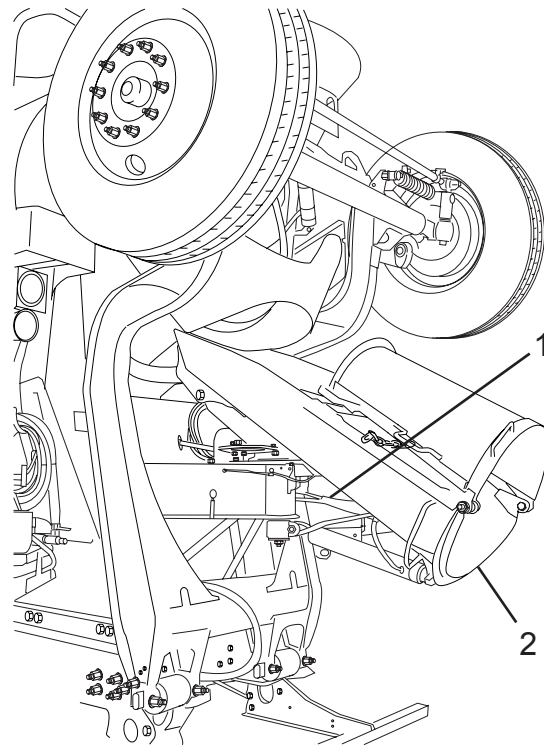

Figure 78

Operation

5.2.4 Manual Drum Operation

5.2.4.1 Manual Override - CHARGE and DISCHARGE

If the mixer cable control fails, and there is still a need to rotate the drum, the control cable can be disconnected to allow the pump drum drive to be engaged manually. This will allow the Mixer to be unloaded.

To engage the drum drive:

1. Pull back and hold the head (Figure 79, Item 1) of the control cable, and lift the end of the cable off the pivot (Figure 79, Item 2) to disconnect the control cable from the pump control lever (Figure 79, Item 3).
2. Move the pump control lever (Figure 79, Item 3) as required to start the drum rotation in the charge or discharge direction.
3. If the drum controls are still disabled after unloading, see Manual Override - Locking for Transit to configure the drum drive for transit.

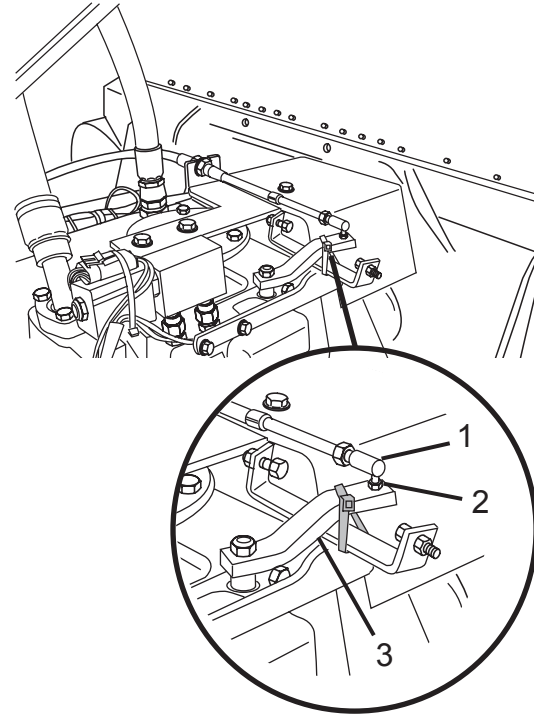

Figure 79

5.2.4.2 Manual Override - Locking for Transit

SAFETY NOTICE

Always rotate drum when truck is in motion. Never stop the drum while driving. Failure to comply may cause damage to property or equipment.

NOTE

Use manual pump overrides for emergency use only. When engaged, drum rotates at speed determined by the pressure applied to override button.

If the mixer cable control fails, and there is still a need to rotate the drum, the control cable can be disconnected to allow the pump drum drive to be engaged manually. This will allow the truck to be driven to the shop for repair.

To manually override the mixer controls:

1. Move the pump control lever (Figure 80, Item 4) to engage the drum drive in the CHARGE direction. Move the lever until the drum is rotating at approximately 1 to 1-1/2 RPM in the CHARGE direction.

2. Secure the lever using a tie strap, wire, or similar item to make sure the drum continues to rotate at the proper speed while in transit to the repair shop.
3. Once the truck is delivered to the repair shop and properly parked, return the pump control lever to the neutral position, and connect the control cable (Figure 80, Item 1) to the pump control lever (Figure 80, Item 4), by pulling back the head (Figure 80, Item 2) of the cable and installing the cable over the pivot (Figure 80, Item 3). Release the cable head (Figure 80, Item 2).
4. Remove the Mixer from service until repairs are completed.
5. Call Revolution Support at (855) 202-6491 if you have questions or need help.

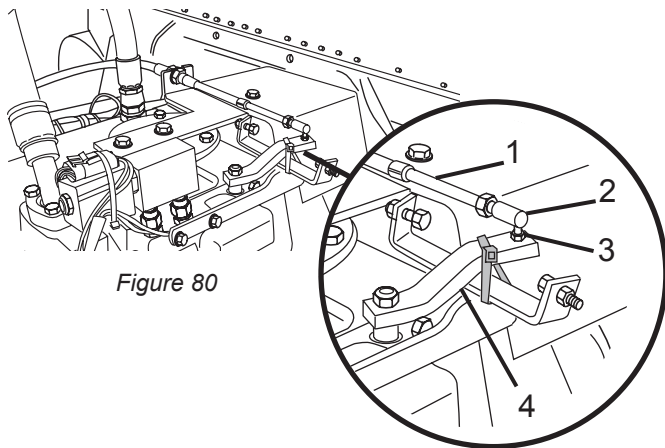

Figure 80

5.3 Cable Control Fuse Functions

If a function in the cab pendant controls or rear pendant controls does not operate, check the condition of the fuses (Figure 81) located in the cover of the control fuse box (in the cab control pendant) or the rear of the control box (cab control box). A label is located beside the fuses to identify the functions they control.

⚠ CAUTION

Do not replace a fuse with a higher amperage fuse than is listed for the location. Always use new fuses of the correct amperage. Failure to comply may cause damage to property or equipment.

Fuse No.	Amperage Rating	Description
1	5 amp	DRUM S/S (Start/Stop) (OPTIONAL)
2	5 amp	DRUM C/D (Charge/Discharge)
3	5 amp	CHUTE LOCK (OPTIONAL)
4	5 amp	CHUTE U/D (Up/Down)
5	10 amp	HOPPER (OPTIONAL)
6	5 amp	Bridgemaster
7	5 amp	Bridgemaster ALARM
8	5 amp	Bridgemaster STOP
9	5 amp	PUSHER/TAG (OPTIONAL)
10	15 amp	FAN
11	20 amp	WORK LT (OPTIONAL)

Fuse No.	Amperage Rating	Description
12	5 amp	FRONT PENDANT (Cab Control Box)
13	10 amp	REAR PENDANT
14	5 amp	OIL TEMP
15	5 amp	Not Used
16	5 amp	Not Used
17	5 amp	Spare Power 01
18	10 amp	Spare Power X1
19	10 amp	Spare Power V1
20	10 amp	Spare Power Q1
21	N/A	Not Used
22	N/A	Not Used
23	N/A	Tag Up Diode
24	N/A	Pusher Up Diode

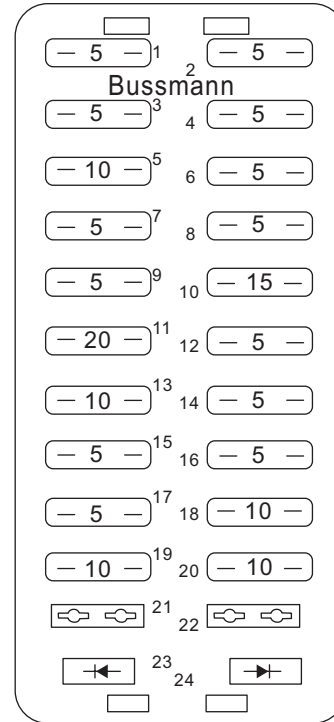
Figure 81

Operation

5.4 Add Water Function (If Equipped)

5.4.1 Manual Water Injection System

Water can be added to the drum by opening the water injection ball valve (Figure 82, Item 1) located at the rear of the Mixer.

Some Mixers may be equipped with an optional valve (Figure 82, Item 3). This valve will automatically close when the handle is released.

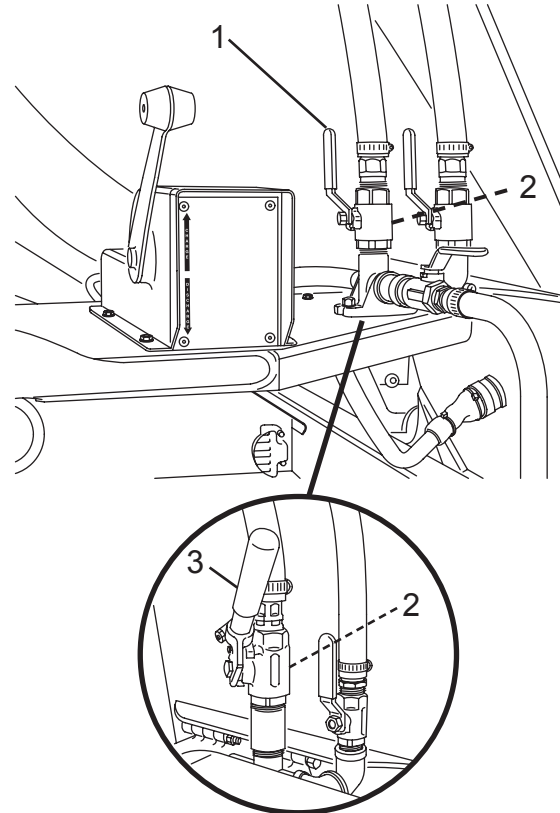

Figure 82

WARNING

Never allow the water from the tank to drain onto a public sidewalk or roadway. Water may cause the sidewalk or roadway to become slippery. Always drain the water system at a location designated by the job site manager or in compliance with your company policy. Failure to comply may result in serious personal injury or death.

Both valves may be equipped with a drain option. This feature automatically drains the water from the hose(s) beyond the valve, through a small hole at the rear of the valve (Figure 82, Item 2).

5.4.2 Remote Water Injection System

This system allows the operator to add water while remaining in the cab by activating the ADD WATER switch on the cab control box. (See “Rocker Switch Functions” for more information.)

To add water:

1. Open the water injection ball valve (Figure 83, Item 1).

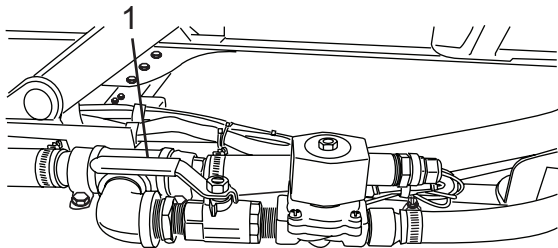

Figure 83

2. Press and hold the ADD WATER rocker switch on the cab control box to activate the system. (See “Rocker Switch Functions” for more information.)
3. Release the rocker switch when the desired amount of water has been added.
4. Close the water injection ball valve (Figure 83, Item 1).

6.0 Control Functions for Traditional Controls

6.1 Bridgemaster Axle Operation

6.1.1 Lowering the Bridgemaster Axle

⚠ WARNING

When operating the Bridgemaster® trailer:

- Never lower and pressurize Bridgemaster trailer when the mixer drum is empty
- Do not coast backward while Bridgemaster trailer is down
- Do not exceed the maximum legal payload, or maximum GVWR or GAWR, whichever is less
- Always adjust pressure to the weight of the payload to be carried
- Always raise the Bridgemaster trailer before backing up
- Bridgemaster trailer must be raised when the truck leaves the roadway or regulated surfaces
- At the job site, use the lowest transmission gear, and proceed at low speed (5 mph [8.3 km/h]) to the discharge area

Failure to follow all these steps may cause serious personal injury or equipment damage.

Operation

1. If possible, position the truck on a firm, level surface.
2. Place the transmission in PARK or NEUTRAL, and engage the parking brake. Allow the engine to run at idle. (Refer to the Operator Manual supplied to the chassis supplier for all parking procedures.)



WARNING

Make sure the front wheels of the truck are securely chocked before raising or lowering the Bridgemaster® trailer. Failure to follow all these steps may cause serious personal injury or equipment damage.

3. When performing service, place wheel chocks or blocks in front of and behind the truck's front wheels.

NOTE

The information on the Bridgemaster axle information placard will vary, depending on the truck configuration.

4. Check with the batch plant operator for the amount of concrete loaded in the Mixer, and compare that information with the Bridgemaster axle information

placard (Figure 84, Item 1).

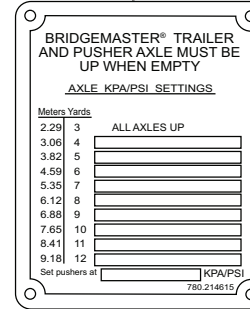
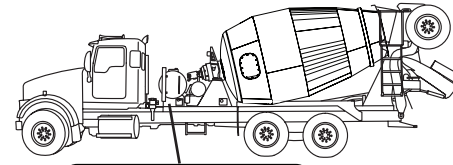

Figure 84

NOTE

The Bridgemaster® pressure gauge may be located near the Bridgemaster valve, or in the truck cab, depending on the Mixer configuration.

- Once the pressure requirements have been determined, use the PRV knob (Figure 85, Item 1) to adjust the valve to the required pressure. Pressure will be displayed on the gauge (Figure 85, Item 2).

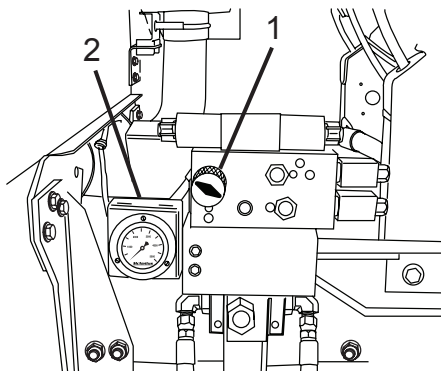

Figure 85

CAUTION

Make sure the fold-over chute is folded and the discharge chute is centered and lowered before raising or lowering the Bridgemaster® trailer. Failure to comply may cause damage to property or equipment.

- Make sure the fold over chute is folded, and the discharge chute is centered and lowered.

WARNING

Crush Hazard. Make sure the area behind the truck is clear of people or obstructions before raising or lowering the Bridgemaster® trailer. The alarm in both the cab and at the rear of the mixer sounds when the trailer is traveling up or down. Keep clear of the area behind the truck and of the trailer pinch points while the trailer is in motion. Failure to comply may result in serious personal injury or death.

- Press and hold the Bridgemaster axle ACTIVATE switch while selecting DOWN on the Bridgemaster axle UP/DOWN rocker switch. (See “Rocker Switch Functions” for more information.)
- The movement of the axle can be reversed by pressing the UP/DOWN rocker switch.
- Remove the wheel chocks or blocks from the front wheels before moving the truck.

NOTE: The Bridgemaster axle automatically raises when the truck is placed in reverse.

NOTE: An alarm buzzer will sound in the cab when

Operation

the Bridgemaster axle is in motion (raising or lowering).

6.1.2 Raising the Bridgemaster Axle

NOTE

If in an emergency situation it becomes necessary to raise or lower the Bridgemaster® trailer manually, the following procedure should be performed by a competent mechanic only.

WARNING

When operating the Bridgemaster® trailer:

- Never lower and pressurize Bridgemaster trailer when the mixer drum is empty
- Do not coast backward while Bridgemaster trailer is down
- Do not exceed the maximum legal payload, or maximum GVWR or GAWR, whichever is less
- Always adjust pressure to the weight of the payload to be carried
- Always raise the Bridgemaster trailer before backing up
- Bridgemaster trailer must be raised when the truck leaves the roadway or regulated surfaces

- At the job site, use the lowest transmission gear, and proceed at low speed (5 mph [8.3 km/h]) to the discharge area
- Failure to follow all these steps may cause serious personal injury or equipment damage.

1. If possible, position the truck on a firm, level surface.
2. Place the transmission in PARK or NEUTRAL, and engage the parking brake. Allow the engine to run at idle. (Refer to the Operator's Manual supplied by the chassis supplier for all parking procedures.)

WARNING

Make sure the front wheels of the truck are securely chocked before raising or lowering the Bridgemaster® trailer. Failure to follow all these steps may cause serious personal injury or equipment damage.

3. Place wheel chocks or blocks in front of and behind the truck's front wheels.

NOTE

The Bridgemaster® pressure gauge may be located near the Bridgemaster valve, or in the truck cab, depending on the Mixer configuration.

4. Turn the PRV knob (Figure 86, Item 1) all the way counterclockwise to minimize the pressure applied to the Bridgemaster axle when the drum is empty. Pressure will be displayed on the gauge (Figure 86, Item 2).

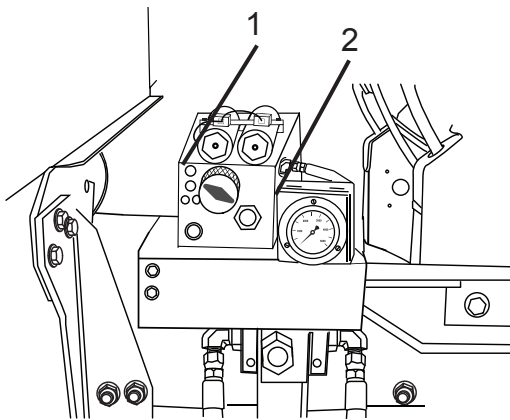

Figure 86

⚠ CAUTION

Make sure the fold-over chute is folded and the discharge chute is centered and lowered before raising or lowering the Bridgemaster® trailer. Failure to comply may cause damage to property or equipment.

5. Make sure the fold-over chute is folded, and the discharge chute is centered and lowered, before raising or lowering the Bridgemaster axle.
6. Locate and remove the end caps from the Bridgemaster directional control valves.

NOTE

The Bridgemaster manual overrides are intended for emergency use only. Valve location may vary, depending on truck configuration.

NOTE

The ends of the valve spools required to RAISE or LOWER and START and STOP may vary, depending on plumbing configurations.

NOTE

The valve spool pin is recessed in the valve end. Use of a tool may be required in order to manually shift the valve spool.

7. Manually shift the start/stop valve spool by pressing in on the end of the spool (Figure 87, Item 1).

WARNING

Crush Hazard. Make sure the area behind the truck is clear of people or obstructions before raising or lowering the Bridgemaster® trailer. The alarm in both the cab and at the rear of the mixer sounds when the trailer is traveling up or down. Keep clear of the area behind the truck and of the trailer pinch points while the trailer is in motion. Failure to comply may result in serious personal injury or death.

8. Engage the Bridgemaster axle function by manually shifting the start/stop valve spool (Figure 87, Item 2).

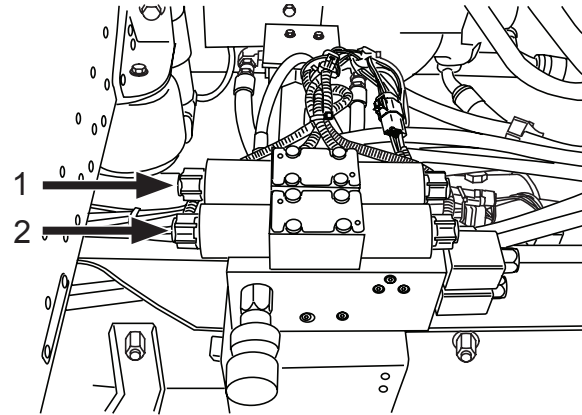

Figure 87

9. Reinstall the end caps to hold coils in place during transport to the repair shop.
10. Remove the wheel chocks or blocks from the front wheels before moving the truck.
11. Once the truck is delivered to the repair shop and properly parked, remove the Mixer from service until repairs are completed.
12. Call Revolution Support at (855) 202-6491 if you have questions or need assistance.

6.1.3 Operation Notes for Bridgemaster Axle

- Axle must be raised anytime the drum is empty.
- Initial operation of the Bridgemaster axle will not begin if the chute hazard indicator shows the chute off to the side or raised.
- A Bridgemaster axle STOP button is provided at the rear pendant control to stop axle motion if desired. The STOP button will also stop the chute raise/lower functions and this function must be reset in the cab controls.
- If changing axle direction during axle movement, system defaults to STOP movement of axle.
- The axle start/stop feature should only be used as such. It is not designed to be used as an on/off switch for the axle.

6.1.4 Bridgemaster Axle Service Brake Operation

The Bridgemaster axle service brakes work in conjunction with the chassis service brake system (all chassis models) and can be configured to also operate with the chassis parking brake system (option).

6.1.4.1 Normal Service Brake Operation (All Chassis Models)

- To engage the Bridgemaster axle service brakes under normal operation, depress the chassis treadle valve (brake pedal).
- To disengage the Bridgemaster axle service brakes under normal operation, release the chassis treadle valve (brake pedal).

6.1.4.2 Parking Service Brake Operation (Option)

- To engage the Bridgemaster axle service brakes with the chassis park brake, pull the chassis parking brake knob out.
- To disengage the Bridgemaster axle service brakes with the chassis park brake, push the chassis parking brake knob in.

Operation

6.1.5 Emergency Manual Bridgemaster Axle Operation

If the Bridgemaster axle controls fail, and there is still a need to raise or lower the Bridgemaster axle, the directional control valve can be operated manually.

6.1.5.1 Lowering the Bridgemaster Axle

NOTE

If in an emergency situation it becomes necessary to raise or lower the Bridgemaster® trailer manually, the following procedure should be performed by a competent mechanic only.

WARNING

When operating the Bridgemaster® trailer:

- Never lower and pressurize Bridgemaster trailer when the mixer drum is empty
- Do not coast backward while Bridgemaster trailer is down
- Do not exceed the maximum legal payload, or maximum GVWR or GAWR, whichever is less
- Always adjust pressure to the weight of the payload to be carried

- Always raise the Bridgemaster trailer before backing up
 - Bridgemaster trailer must be raised when the truck leaves the roadway or regulated surfaces
 - At the job site, use the lowest transmission gear, and proceed at low speed (5 mph [8.3 km/h]) to the discharge area
- Failure to follow all these steps may cause serious personal injury or equipment damage.

1. If possible, position the truck on a firm, level surface. Place the transmission in PARK or NEUTRAL, and engage the parking brake. Allow the engine to run at idle. (Refer to the Operator's Manual supplied by the chassis supplier for all parking procedures.)

WARNING

Crush Hazard. Make sure the area behind the truck is clear of people or obstructions before raising or lowering the Bridgemaster® trailer. The alarm in both the cab and at the rear of the mixer sounds when the trailer is traveling up or down. Keep clear of the area behind the truck and of the trailer pinch points while the trailer is in motion. Failure to comply may result in serious personal injury or death.

- When performing service or emergency operation, place wheel chocks or blocks in front of and behind the truck's front wheels.

NOTE

The information on the Bridgmaster axle information placard will vary, depending on the truck configuration.

- Check the amount of concrete loaded in the Mixer, and compare that information with the Bridgmaster axle information placard (Figure 88, Item 1).

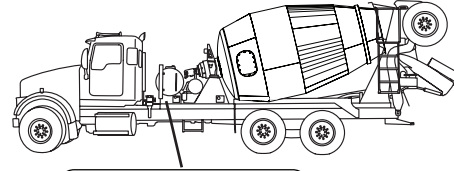

**BRIDGEMASTER® TRAILER
AND PUSHER AXLE MUST BE
UP WHEN EMPTY**

AXLE KPA/PSI SETTINGS

Meters	Yards	
2.29	3	ALL AXLES UP
3.06	4	
3.82	5	
4.59	6	
5.35	7	
6.12	8	
6.88	9	
7.65	10	
8.41	11	
9.18	12	

Set pushers at KPA/PSI

780-214615

Figure 88

Operation

- Once the pressure requirements have been determined, use the PRV knob (Figure 89, Item 1) to adjust the pressure to the required pressure. Pressure will be displayed on the gauge (Figure 89, Item 2).

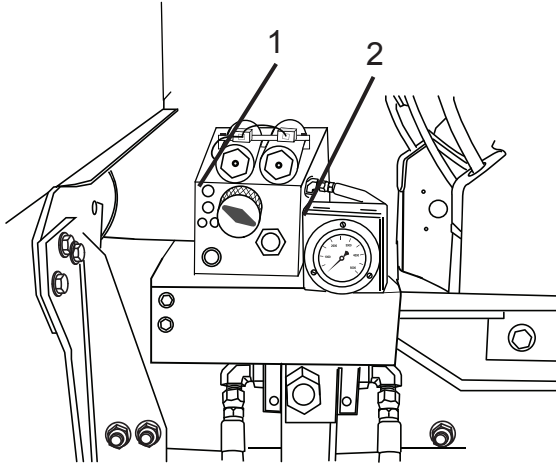

Figure 89

CAUTION

Make sure the fold-over chute is folded and the discharge chute is centered and lowered before raising or lowering the Bridgemaster® trailer. Failure to comply may cause damage to property or equipment.

- Manually fold the fold-over chute, and make sure the discharge chute is centered and lowered.

WARNING

Crush Hazard. Make sure the area behind the truck is clear of people or obstructions before raising or lowering the Bridgemaster® trailer. The alarm in both the cab and at the rear of the mixer sounds when the trailer is traveling up or down. Keep clear of the area behind the truck and of the trailer pinch points while the trailer is in motion. Failure to comply may result in serious personal injury or death.

NOTE

The Bridgemaster manual overrides are intended for emergency use only. Valve location may vary, depending on truck configuration.

NOTE

The ends of the valve spools required to RAISE or LOWER and START and STOP may vary, depending on plumbing configurations.

NOTE

The valve spool pin is recessed in the valve end. Use of a tool may be required in order to manually shift the valve spool.

6. Locate and remove the end caps from the Bridgemaster directional control valves.
7. Manually shift the start/stop valve spool by pressing in on the end of the spool (Figure 90, Item 1).
8. Manually shift the raise/lower valve spool by pressing in on the end of the spool (Figure 90, Item 2).

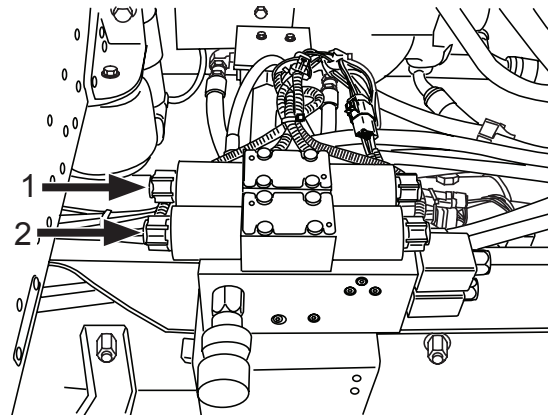

Figure 90

9. Reinstall the end caps to hold coils in place during transport to the repair shop.
10. Remove the wheel chocks or blocks from the front wheels before moving the trucks.
11. Once the truck is delivered to the repair shop and properly parked, remove the Mixer from service until repairs are completed.
12. Call Revolution Support at (855) 202-6491 if you have questions or need assistance.

7.0 Operating Procedures

7.1 Start-Up Procedure

NOTE

Perform pre-trip inspection of chassis and Mixer according to all federal, state, and local laws.

Before starting the vehicle, make certain that all daily checks have been completed and verified. (See 3.0 Preventive Maintenance Daily Checks.)

Perform a walk-around inspection to verify that all controls and components (main and fold-over chutes, chute extensions, hoses, etc.) are properly stored and secured.

7.2 Warm-Up Procedure

At start-up of the equipment each morning, it is important to cycle through each of the main hydraulic and air circuits to be certain each circuit is functioning properly. Cycling through each operation also helps ensure that the hydraulic fluid is up to operating temperature and is present throughout the system.

Cycle through each of the following operations:

1. Main Chute Functions – Cycle 3 times
2. Chute Air Lock Function (if equipped) – 1 time
3. Flip-Up Charge Hopper Function (if equipped) – 1 time

NOTE

Allow the hydraulic oil to warm to operating temperature before rotating the drum.

4. Drum Functions – Rotate in CHARGE and DISCHARGE direction for 5 minutes.

CAUTION

If you detect a problem with any control function, it must be repaired immediately. DO NOT operate the Mixer with malfunctioning controls. Failure to comply may cause damage to property or equipment.

After completing the cycle tests, inspect the Mixer for any hydraulic leaks. If leaks are detected, correct them BEFORE the Mixer is placed into operation.

7.3 Adjusting the Throttle Speed

When using the rear pendant or Wireless Remote Control option to adjust the throttle speed, the procedures will vary, depending on the engine installed in the chassis. Check the chassis information supplied with the Mixer to determine which engine is installed in your truck.

NOTE

Depressing the chassis brake pedal will disengage the cruise control and cause the engine speed to return to idle. The cruise control must be engaged to throttle.

7.3.1 Mack® Engines

To use the Rear Throttle Controls:

- Ensure the parking brake is set and the Mixer is in NEUTRAL
 - Drum STOP must be OFF (drum must be turning)
 - Constant Speed must be OFF
1. Press and release the Throttle Raise button (rabbit icon) to achieve maximum PTO speed.

2. Press and release the Throttle Lower button (turtle icon) to achieve pouring PTO speed (normally 1200 RPM)
3. To bring remote PTO speed back to idle, press and hold the Throttle Lower button (turtle icon).

7.3.2 Mack® Engines – Wireless Remote Control

To use the Wireless Transmitter:

- Ensure the parking brake is set and the Mixer is in NEUTRAL
 - Drum STOP must be OFF (drum must be turning)
 - Constant Speed must be OFF
1. Press and release the Throttle Raise button (rabbit icon) to achieve maximum PTO speed.
 2. Press and release the Throttle Lower button (turtle icon) to achieve pouring PTO speed (normally 1200 RPM)
 3. To bring remote PTO speed back to idle, press and hold the Throttle Lower button (turtle icon).

Operation

7.3.3 Cummins® Engines

To use the Rear Throttle Controls:

- **Ensure the parking brake is set and the Mixer is in NEUTRAL**
 - Drum STOP must be OFF (drum must be turning)
 - Constant Speed must be OFF
1. Press and release the Throttle Raise button (rabbit icon) to achieve maximum PTO speed.
 2. Press and release the Throttle Lower button (turtle icon) to achieve pouring PTO speed (normally 1200 RPM).
 3. To bring remote PTO speed back to idle, press and hold the Throttle Lower button (turtle icon).

7.4 Platform Gate Bar Usage (Optional Equipment)

If equipped with the upper ladder platform gate bar, follow these instructions for proper usage of the bar.

1. To enter the platform, push the bar up and in to create enough room to step onto the platform.
2. Lower the bar to return it to its starting position when you are on the platform.

3. To exit the platform, push the bar up and pull it in and exit the platform.
4. Return the bar to its starting position.

7.5 Loading the Mixer Drum

There are three types of concrete mixes that may be loaded into the Mixer. Each type of concrete has different mixing requirements.

The three mix types are:

Truck Mixed Concrete: In truck mixed concrete, all of the ingredients are charged directly into the truck mixer. No plant mixing is involved. Some or all of the mixing water is usually introduced at the plant.

Shrink Mixed Concrete: Shrink mixed concrete is partially mixed in a plant mixer and the concrete is then loaded into a truck mixer. Mixing is completed in the truck mixer.

Central Mixed Concrete: Central mixed concrete is completely mixed in a plant mixer.

1. If equipped with a flip-up charge hopper, make sure the hopper is lowered.
2. Pull or back the Mixer into the plant's load lane.
3. Position the charge hopper directly under the discharge chute at the batch plant.

4. Set the engine speed to maximum governed RPM.
5. Place the drum control into fast charge. The optimum drum speed for loading will vary.
6. For Revolution INSIGHT System only: Use LOAD mode through the optional in-cab control keypad.
7. After loading is complete, check the concrete slump and add water as needed.
8. Set the drum control to the CHARGE direction at the lowest drum speed.
9. Fill the water tank(s). In cold weather, the water may be hot, so be extremely careful.
10. Rinse the charge hopper.
11. Pick up delivery ticket, and make sure the ticket matches the materials loaded in your truck.

NOTE

The mixer drum should be rotating in the CHARGE direction at all times when the drum is filled with concrete and not discharging.

NOTE

Proper mixing speed for the drum is 12 to 14 rpm. In general, a proper mix can be obtained with 70 revolutions (at maximum drum speed) of the mixer drum. This count begins when the Mixer is fully loaded and ends when the Mixer begins transport to the job site. During transport, the drum speed should be approximately 1-1/2 rpm.

CAUTION

Liquid nitrogen should be applied directly to the concrete mix. If liquid nitrogen comes in direct contact with the drum, it could lead to early drum component failure. Failure to comply may cause damage to property or equipment.

7.5.1 Working Around Concrete Pumps

Refer to the NRMCA's Mixer Truck Driver's Manual that is placed in the vehicle's cab for helpful information regarding working around concrete pumps. Contact the National Ready Mixed Concrete Association (NRMCA) or Revolution Concrete Mixers for a copy of the manual if required.

Operation

7.6 Traveling to the Job Site

Before beginning travel to the job site, be sure that the Mixer is properly prepared for travel. This means that:

1. Access ladder(s) are folded up and securely latched.
2. Rear control pendant is properly stowed and secured.
3. Chute and chute extensions are clean and free of concrete and debris.
4. Chute extensions are properly stowed and secured.
5. Wash-out hose(s) are properly stowed and secured.
6. Fold-over chute is folded over the main chute and is properly secured.
7. Main chute is positioned with the end of the chute pointing toward the curb, and is locked using the manual chute lock.

WARNING

Burst Hazard. Never drive the truck with the water tank pressurized. Failure to comply may result in serious personal injury or death.

8. Water tank(s) are filled and depressurized and the water system is purged.
9. Bridgemaster axle and/or pusher axle(s) are lowered (as needed). (See 3.13 Bridgemaster Axle Operation.)

CAUTION

Do not stop the drum while in transit. Driving the vehicle without the drum rotating may cause damage to the equipment.

10. Drum is rotating in the CHARGE direction (CW) and is set at the proper speed (approximately 1 to 1-1/2 RPM, slower for longer transport distances, higher for shorter transport distances).

7.7 Positioning the Truck for Discharge

Before pulling into the pour site (parking site for the truck when unloading concrete), be sure the site is properly prepared for the truck. This means that:

1. It will be necessary to inspect the proposed access route to the pour site and the pour location to make sure it is safe to proceed.
 - If any hazards are noted, an alternate route must be determined or, if possible, the hazards must be removed.

WARNING

At the job site, use the lowest transmission gear and proceed at low speed, 3 mph (4.8 km/h) maximum, to the discharge area. Failure to comply may result in serious personal injury or death.

2. Drive the Mixer slowly to the pour site, staying on the predetermined route.

DANGER

Crush Hazard. Never back up without taking every precaution to be sure the rear is clear. Watch mirrors for activity. Never back up the Mixer unless and until you are completely sure it is safe. Use a spotter/observer and/or get out and check yourself to ensure it is safe to do so. Failure to comply will result in serious personal injury or death.

3. If it is necessary to back the truck to the pour site, use a spotter to guide you into the site. The spotter should be standing to the side in clear view of your mirrors. The area behind the truck must be free of any other people.

7.8 Chute Operation

7.8.1 Unfold the Fold-Over Chute

WARNING

Crush Hazard. Do not let persons, other than the driver, handle the chutes, unfold the fold-over, and/or remove extension, or stow and secure the extensions for transit. Keep hands away from chute hardware where the chutes connect. Never stand in the path of the chute as it is being unfolded or while in use. Failure to comply may result in serious personal injury or death.

CAUTION

Do not move vehicle with fold-over chute extended and chute extensions installed unless actively discharging concrete at job site. Failure to comply may cause damage to property or equipment.

NOTE

If the mixer is equipped with an optional hydraulic fold-over chute, see Hydraulic Fold-Over Chute for more information.

1. Position the main chute so that there is sufficient room behind the chute. Lock the main chute using the manual chute lock or the optional chute air lock.
2. Disconnect the retaining chain (Figure 91, Item 1) from the fold-over chute (Figure 91, Item 2).
3. Grasp the fold-over chute by the handles (Figure 91, Item 3), and pivot the fold-over chute down until it firmly engages the main chute.

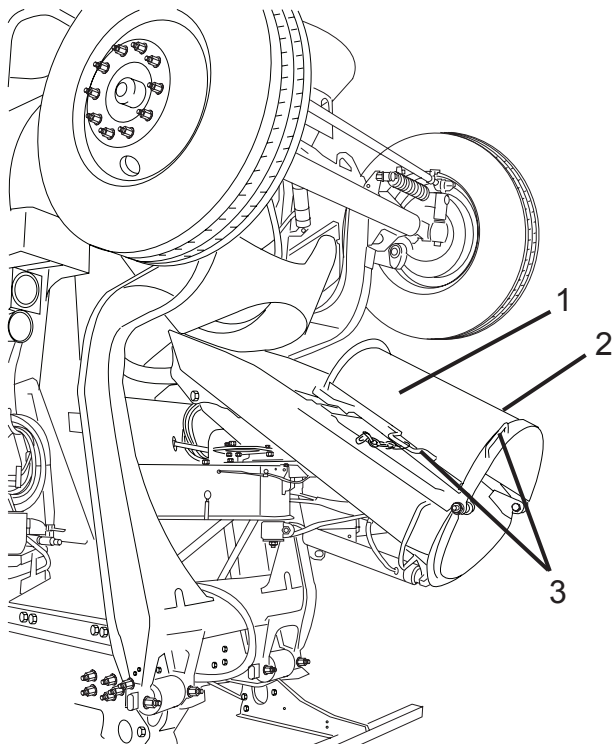

Figure 91

7.8.2 Using Chute Extensions

WARNING

Do not over-load chute extensions. Maximum load capacity of 400 lbs. per chute extension. Failure to comply may result in serious personal injury or death.

WARNING

Inspect chute extensions prior to each use. Never use a damaged chute extension or a chute extension that has been driven over. Replace damaged chutes extensions immediately. Failure to comply may result in serious personal injury or death.

DANGER

Crush Hazard. Never stand on a chute or chute extensions. Do not use the chute as a crane to pull or transport objects. Failure to comply will result in serious personal injury or death.

⚠ CAUTION

Do not move vehicle with fold-over chute extended and chute extensions installed unless actively discharging concrete at job site. Failure to comply may cause damage to property or equipment.

⚠ WARNING

Crush Hazard. Do not let persons, other than the driver, handle the chutes, unfold the fold-over, and/or remove extension, or stow and secure the extensions for transit. Keep hands away from chute hardware where the chutes connect. Never stand in the path of the chute as it is being unfolded or while in use. Failure to comply may result in serious personal injury or death.

⚠ CAUTION

Crush Hazard. Do not use more chute extensions than are specified for your Mixer. Do not use any other type or style of chute extensions, other than ones designed for use with your Mixer. Failure to comply may cause damage to property or equipment.

1. Lock the main chute lock or optional chute air lock.
2. Unfold the fold-over chute.
3. Remove the number of chute extensions needed for the pour from chute storage.
4. Install the needed number of chute extensions on the fold-over chute. Never exceed three chute extensions.

7.8.3 Position the Discharge Chute Assembly

⚠ CAUTION

Do not move vehicle with fold-over chute extended and chute extensions installed unless actively discharging concrete at job site. Failure to comply may cause damage to property or equipment.

1. Grasp the main chute handle and release the main chute lock using the manual chute lock or optional chute air lock.
2. Move the discharge chute to the desired location and lock the main chute with the manual chute lock or optional chute air lock.
3. Raise the main chute as needed using the CHUTE UP/DOWN switch on the rear pendant.

WARNING

Crush Hazard. When the chute lock is released, the chute may shift unexpectedly, especially if the truck is parked on an incline. Secure the chute before releasing the chute lock. Failure to comply may result in serious personal injury or death.

4. If it becomes necessary to move the chute while discharging:
 - a. Hold the chute securely.
 - b. Release the main chute lock using the manual chute lock or optional chute air lock.
 - c. Move the chute to the desired location.
 - d. Lock the chute using the manual chute lock or optional chute air lock.
5. If it becomes necessary to move the truck to a new location in order to continue discharging the load:
 - a. Stop discharging.
 - b. Remove the chute extensions.

NOTE

If moving the truck less than 15 feet (4.6 meters), the fold-over chute may be left extended.

- c. Fold the fold-over chute.
- d. Move the truck to the new location and install the chute extensions.

7.9 Discharging the Load

1. Park the truck safely. (Refer to the Operator's Manual supplied by the chassis supplier for all parking procedures.) The engine can remain at idle.
2. Unfold the fold-over chute and install chute extensions as needed.
3. Position the discharge chute assembly as needed.
4. If discharging low slump concrete, move the charge hopper away (if equipped with a flip-up or Swing Away Throat charge hopper).
5. To discharge, set the engine speed to 1100 to 1200 RPM, and set the drum control to DISCHARGE direction at the desired speed. A drum speed of 2 RPM will be sufficient for most work; however, greater or lesser speeds can be used, depending on the job conditions and type of concrete mix. A good

Operation

rule of thumb to follow is, the higher the slump of the concrete, the greater the allowable drum RPM; the lower the slump, the slower the drum should rotate for maximum discharge rate.

6. The main chute position is easily controlled by adjusting the chute height with the chute lifter and rotating the chute manually with the chute lifter and rotating the chute manually about its pivot point. A lock system is provided to lock the chutes and prevent rotation when leaving the purging position.
7. If it is necessary to add water to the concrete mix before discharging the load, activate the water injection system.

7.10 Wash Down the Mixer Before Leaving the Job Site

WARNING

The chassis transmission must be in neutral and the parking brake set before attempting to operate the mixer with external controls. Failure to comply may result in serious personal injury or death or extensive machine damage.

NOTE

The actual wash-down procedure may vary, depending on your company policies and procedures, and may or may not include all of the following steps.

NOTE

Do not discharge leftover concrete on the job site or anyway else, unless specifically instructed to do so by a company manager. Return leftover concrete to the plant for proper disposal.

1. Move the Mixer to the designated clean-out area.
2. Park the truck safely. (Refer to the Operator's Manual supplied by the chassis supplier for all parking procedures.)

NOTE

Never allow concrete wash water to enter a catch basin, creek, or storm drain, or flow onto the road or gutter. Never flush the drum out on the job site; this should be done only in the proper designated area at the plant yard. Improper discharge of wash water is illegal and can result in fines.

3. Set the mixer drum to rotate in the CHARGE position at no more than 4 RPM.

 WARNING

While washing down the mixer, use only those surfaces and areas designated for standing on to perform the procedure. Avoid surfaces of any type that are wet or slippery. Failure to comply may result in serious personal injury or death.

 WARNING

Fall Hazard. Use the three-point contact method (either two hands and one foot, or two feet and one hand on the ladder at all times) when climbing the ladder. Always face the ladder when climbing up or down. Failure to comply may result in serious personal injury or death.

 WARNING

Fall Hazard. Do not allow anyone but a trained operator to climb on ladders. Failure to comply may result in serious personal injury or death.

4. If equipped, turn the wash-out system ON.

5. Turn on the wash-out hose valve (Figure 92, Item 4).
6. Unfold the access ladder (Figure 92, Item 5).

NOTE: The fins, charge hopper, collector, and other components on the rear of the Mixer can be washed from the ground using the wash-out hoses instead of standing on the platform.

 WARNING

High Pressurized Fluid Hazard. When using pressurized water, spray water at an angle to prevent splash-back. Never aim pressurized water toward another person. Failure to comply may result in serious personal injury or death.

7. Using the wash-out hose (Figure 92, Item 1), start at the top and wash out the charge hopper (Figure 92, Item 2), the interior of the drum, the main chute (Figure 92, Item 3), and chute extensions.

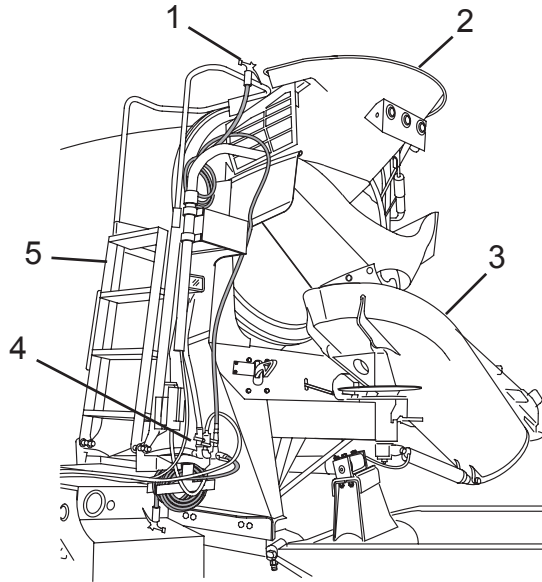

Figure 92

8. Check for concrete build-up; make a note of any concrete that cannot be washed out for future reference. Let the equipment manager know about excessive build-up.
9. Wash any spilled/splashed concrete and/or debris from the exterior of the drum, rear pedestal, fenders, and any surface of the Mixer as needed.

10. Remove and properly stow the chute extensions. Wash off any concrete that may have been missed before storing the chute extensions.
11. Turn off the wash-out hose valve.
12. Depressurize the water tank(s) and purge the water system.

WARNING

Never allow the water from the tank to drain onto a public sidewalk or roadway. Water may cause the sidewalk or roadway to become slippery. Always drain the water system at a location designated by the job site manager or in compliance with your company policy. Failure to comply may result in serious personal injury or death.

SAFETY NOTICE

Be sure to drain the water system after each use when operating in temperatures below freezing. Failure to comply may cause damage to property or equipment.

13. If operating in temperatures below freezing, the water tank(s) must be drained. (See 9.3 Draining the Water System for a pressurized water system or for a pump water system.)
14. Properly stow the wash-out hose(s).
15. Return the fold-over chute to the STORAGE position, and position and lock the main chute in the TRANSPORT position, using the manual chute lock.
16. Fold up the access ladder and make sure it is securely latched.

7.11 Returning from the Job Site

Before beginning travel from the job site back to the plant, be sure that the Mixer is properly prepared for travel.

This means that:

- All access ladders are folded up and securely latched
- Rear control pendant is properly stowed and secured
- All spilled concrete is washed off the Mixer
- Mixer and chassis surfaces are free of mud or debris that may be dropped on the road or thrown onto cars while driving

- Chute and chute extensions are clean and free of concrete and debris
- Chute extensions are properly stowed and secured

DANGER

Crush Hazard. Chute extensions must be secured on the truck before leaving the job site. Failure to comply will result in serious personal injury or death.

- Wash-out hose(s) is properly stowed and secured
- Main chute is positioned with the end of the chute pointing toward the curb, and is locked using the manual chute lock
- Water tank(s) is depressurized
- If operating in temperatures below freezing, the water tank(s) should be drained

SAFETY NOTICE

Always rotate drum when truck is in motion. Never stop the drum while driving. Driving the truck without the drum rotating will damage equipment. Failure to comply may cause damage to property or equipment.

- Drum is rotating in the CHARGE direction (CW) and is set at the proper speed (approximately 1 to 1-1/2 RPM)

7.12 End-of-Day Cleaning Procedure

Keeping the drum clean is important to ensure proper operation and extend drum life. The drum should be cleaned thoroughly at the end of each work day.

1. Empty the mixer drum of all remaining contents per company policy.
2. Set drum to rotate at maximum speed in the CHARGE direction and add approximately 150 to 200 gallons (568 to 757 liters) of fresh or recycled water to the drum.
3. Run the drum at mixing speed for approximately two minutes.
4. Move the Mixer to the appropriate sedimentation pit or pond, or to a reclaimer. Change the drum rotation to the DISCHARGE direction and empty the drum contents.
5. If needed, add 30 to 40 gallons (114 to 150 liters) of water to the drum for a final rinse.
6. Wash the exterior of the Mixer.

7.12.1 End-of-Day Checks

At the end of the day, make certain that:

1. The Mixer drum and chutes are thoroughly washed out.
2. The water system is drained. (See 9.3 Draining the Water System for a pressurized water system or for a pump water system.)
3. Place the drum drive in the neutral position before shutting down.
4. All equipment is properly shut down.
5. The truck is parked on a firm, level surface. (Refer to the Operator's Manual supplied by the chassis supplier for all shut-down and parking procedures.)
6. Report any mechanical/electrical/hydraulic problems to the appropriate people so that repairs can be made.

8.0 Water Tanks

8.1 Water Tank Safety

WARNING

IMPORTANT ALUMINUM AND STEEL WATER TANK INFORMATION.

1. Inspect water tank on a daily basis for any damage including, but not limited to, dents, gouges in metal, or leaks.
2. Do not weld on or repair water tank. Instead, replace water tank with a new OEM water tank.
3. Never pressure test an empty water tank. Only pressure test a full water tank.
4. Never remove pressure regulator or pressure safety valve from tank.
 - If regulator or safety valve is defective, it must be replaced before Mixer is put into service.
5. Do not pressurized water tank beyond its working pressure.

- If pressure exceeds the working pressure, immediately depressurize water tank and replace pressure regulator and pressure safety valve.
6. Never drive the truck with the water tank pressurized.
 - Depressurize water tank prior to transit to or from job site.
 - Water tank should be pressurized only when being used.
 7. Never modify water tank in any way.
 8. Immediately replace safety decals with OEM decals if decals are missing or difficult to read.
 9. Refer to the Revolution Operator's Manual or contact Revolution at (855) 202-6491 if you have questions or require assistance.

Operation

8.2 Water Tank Operation

8.2.1 Introduction

Your mixer may be equipped with a pressurized water tank. This tank is used to add water to a concrete mix, and to provide a source of water pressure for washing down the chutes and the drum. The air pressure from the truck's auxiliary air system is used to provide pressure to the tank. Use these instructions for the safe operation and inspection of all Revolution and London pressurized water tanks.

If your mixer is equipped with a non-pressurized water tank (a system that uses a water pump to provide pressure), refer to the instructions provided with the mixer.

8.2.2 Daily Operation

8.2.2.1 Tank Integrity

At the start of each shift:

- **Inspect Interior:** Drain the tank of water and use a flashlight to look into the tank through the fill opening. Look for signs of corrosion on the inside of the tank which may indicate that the tank has been weakened and is in need of replacement.

- **Inspect Exterior without Pressure:** If the interior inspection indicates that the tank is in good condition, fill the tank with water and inspect the exterior of the tank thoroughly for signs of leaks. Inspect the filler neck and fill opening. Look for signs of damage. Look for cracks in the weld joints or seams. Check that all fastening hardware is tight and undamaged. Inspect fittings for signs of damage, cracks, or looseness.
- **Inspect Exterior with Pressure:** If there are no signs of exterior leakage, pressurize the tank and repeat the inspection.
- **Depressurize Tank:** Release the pressure in the tank as soon as you are finished inspecting and before moving the truck.
- **Replace Defective Tank:** Water tanks with any leak or significant signs of internal or external damage or corrosion should be replaced. **DO NOT ATTEMPT TO REPAIR.**

8.2.2.2 Pressure Regulator Valve

Inspect Pressure Regulator: The pressure regulator is used to reduce the air brake system pressure to a pressure that is safe to be used in the water tank. It must be undamaged and in proper working order. Look and listen for signs of leaking. Ensure that the valve and

associated hoses and fittings are undamaged.

Adjust Pressure to Correct Setting: Many pressure regulators are set at the factory and cannot be adjusted. If your water tank has an adjustable regulator, set it to 50 psi. When setting the regulator, always begin by turning the adjusting knob counterclockwise first to reduce the pressure slightly. Then turn it clockwise slowly to bring the pressure up to the correct setting. Never continue to turn the valve past the correct setting.

Replace Defective Regulator Valve: Any water tank with a damaged or missing pressure regulator valve must be removed from service immediately. Do not pressurize the tank until a functioning pressure regulator valve has been installed.

8.2.2.3 Pressure Relief Valve

Inspect the Relief Valve: The pressure relief valve is a safety device that will release air or water from the tank if it is inadvertently pressurized over the relief setting. The relief setting on most water tanks is set at the factory and cannot be adjusted. Identify the pressure relief valve and ensure that it has not been damaged or tampered with.

Replace Defective Relief Valve: Any water tank with a damaged or missing pressure relief valve must be removed from service immediately. Do not pressurize

the tank until a functioning pressure relief valve has been installed.

8.2.3 Daily Operation

The water tank is designed to be used during stationary operation at the yard or the job site only. It is not necessary or beneficial for the tank to be pressurized while driving, and a pressurized tank is an added hazard in the event of a crash or a rollover.

8.2.4 Vehicle Handling Characteristics

Safe operation of any vehicle is the responsibility of the driver. Concrete trucks have a significantly higher rollover tendency than other types of vehicles due to a higher center of gravity and the affect of concrete shifting in the drum. The water tank is also a fluid load that can increase the rollover tendency if the truck is driven with the water tank partially full. To reduce the risk of rollover, only drive a loaded truck (concrete in the drum) with the water tank either completely full or completely empty. Avoid making sharp turns at excessive speeds and other abrupt maneuvers.

In the event of a rollover or crash, an unbelted person is significantly more likely to become injured or die than a person wearing a seat belt. ALWAYS WEAR YOUR SEAT BELT.

8.3 Water Tank Safety Sign Identification

No.	Part Number	Qty.	Comments
A	1449162	1	Use if equipped with 55 psi tank.
A	1449165	1	Use if equipped with 95 psi tank.
A	1503949	1	Use if equipped with 120 psi tank.
B	1449164	1	

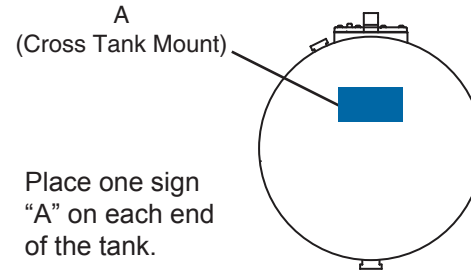
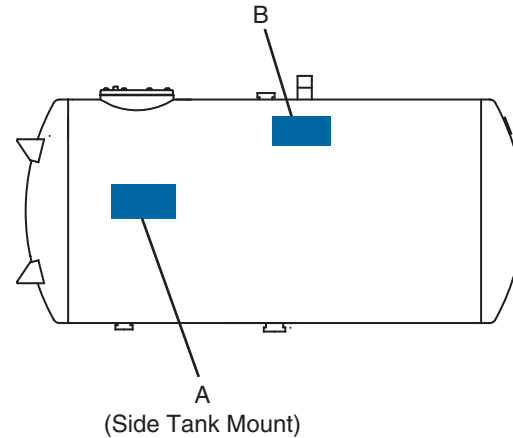

8.4 Water Tank Mounting Positions

The water tank(s) can be mounted in one of several locations, depending on the Mixer configuration and options.

8.5 Standard Water Tank

Mixers are equipped with at least one water tank to provide water for adjusting the slump and for cleaning. Additional water tanks are optional.

WARNING

NEVER drink the water from a water tank. The water tank may contain residue from chemicals used to modify concrete properties. Failure to comply may result in serious personal injury or death.

WARNING

NEVER modify the water tank(s) in any way. Failure to comply may result in serious personal injury or death.

8.5.1 Single Sight Gauge

The water tank sight gauge (Figure 93, Item 1) allows the operator to view the water level in the tank. The sight gauge is equipped with isolator valves (Figure 93, Items 2 and 3) that can isolate the sight gauge from the pressurized water tank in the event the sight gauge tube is broken.

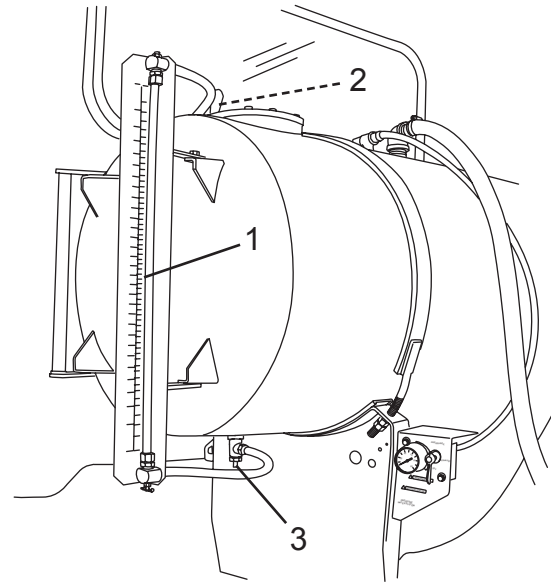

Figure 93

Operation

8.6 Split Water Tank (Optional)

Some Mixers can be equipped with a split water tank. This tank provides a main compartment for water and a smaller compartment (usually 15 or 25 gallon [57 or 95 liter] capacity) that may be used to hold a chemical solution.

8.6.1 Dual Sight Gauges

On Mixers equipped with split water tanks, the water tanks will have two sight gauges. One sight gauge will indicate the level of the chemical tank (Figure 94, Item 1). This tank can have a capacity of 15 or 25 gallons (57 or 95 liters).

The other sight gauge (Figure 94, Item 2) will indicate the level of the main water tank.

The sight gauges are equipped with isolator valves that can isolate the sight gauges from the pressurized water tank in the event a sight gauge is broken. Valves are located at the top and bottom of the sight gauges.

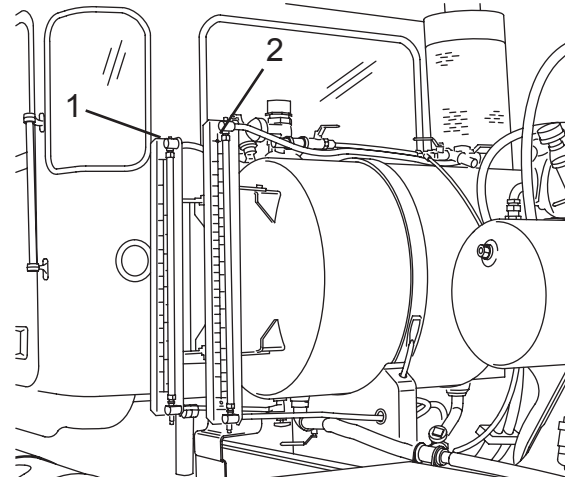

Figure 94

9.0 Water System - Pressurized

⚠ WARNING

Burst Hazard. Never drive the truck with the water tank pressurized. Failure to comply may result in serious personal injury or death.

9.1 Depressurizing the Water Tank

1. Turn air pressure control valve to EXHAUST position (Figure 95, Item 1). Make sure the gauge (Figure 95, Item 2) reads 0 PSI (0 kPa).

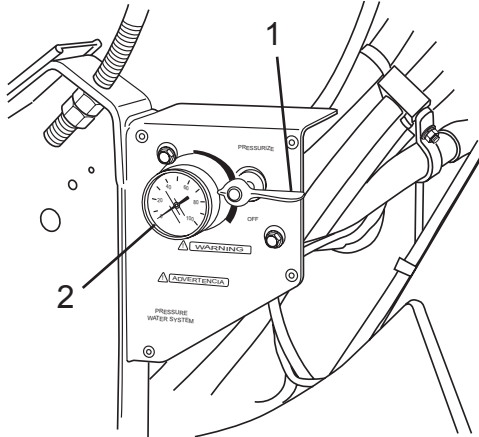

Figure 95

2. After pressure in the water tank has been completely exhausted, turn the air pressure control valve to the OFF position (Figure 96, Item 1).

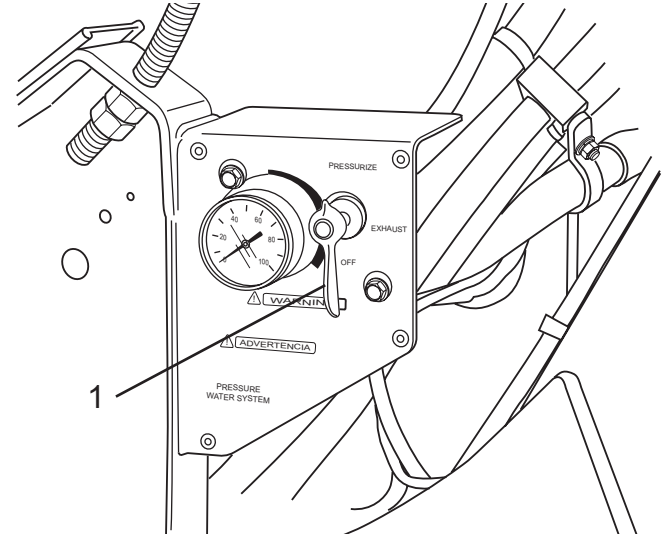

Figure 96

9.2 Pressurizing the Water Tank

1. Open the air valve (Figure 97, Items 1 or 2) of the tank compartment to be pressurized. If equipped with an optional split tank, each compartment will have its own valve.

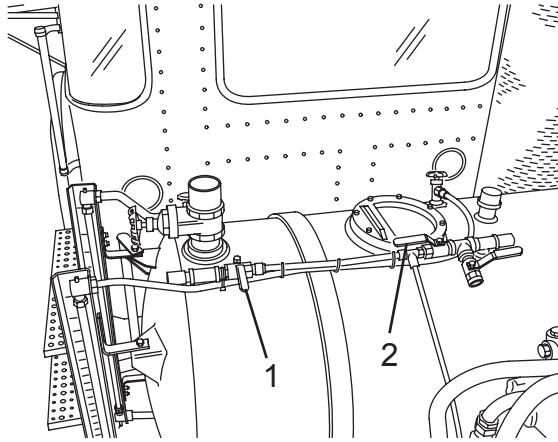

Figure 97

WARNING

Burst Hazard. Never pressurize water tank in excess of 55 psi (380 kPa). If pressure exceeds 55 psi (380 kPa), depressurize the water tank immediately and adjust or replace the air regulator valve. Failure to comply may result in serious personal injury or death.

2. Turn air pressure control valve to the PRESSURIZE position (Figure 98, Item 1). The water tank will be pressurized from the chassis air system. The air gauge (Figure 98, Item 2) will indicate the pressure in the water tank. The pressure must not exceed 55 psi (380 kPa).

WARNING

Burst Hazard. Never pressurize an empty water tank. Failure to comply may result in serious personal injury or death.

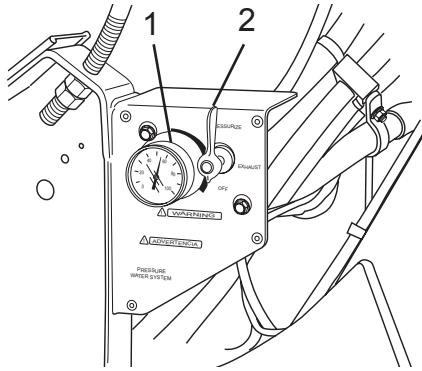

Figure 98

9.3 Draining the Water System

WARNING

Never allow the water from the tank to drain onto a public sidewalk or roadway. Water may cause the sidewalk or roadway to become slippery. Always drain the water system at a location designated by the job site manager or in compliance with your company policy. Failure to comply may result in serious personal injury or death.

SAFETY NOTICE

Be sure to drain the water system after each use when operating in temperatures below freezing. Failure to comply may cause damage to property or equipment.

NOTE

When draining the chemical tank, the contents should be drained into a properly marked container. The container should be stored for reuse, or the contents should be disposed of in compliance with all applicable regulations.

When operating in temperatures below freezing, the water system must be drained after every use.

1. Depressurize the water tank(s).
2. Remove the water tank drain plug(s), or open the main tank (Figure 99, Item 5) and chemical tank (if equipped) drain valves (Figure 99, Item 3).
3. Open the main tank (Figure 99, Item 4) and chemical (if equipped) sight glass isolator valves (Figure 99, Item 2).
4. Open the sight glass drain valves (Figure 99, Item 1).

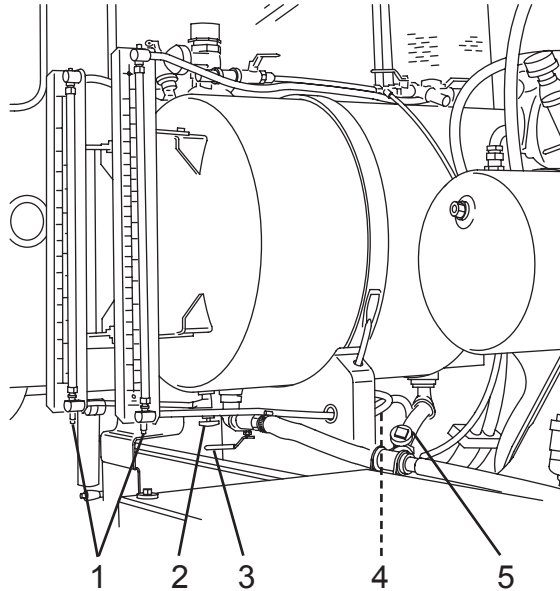

Figure 99

5. Open wash-out hose valve (Figure 100, Item 3) at the rear of the Mixer and allow water to drain.
6. Open drum wash-out valve (if equipped) (Figure 100, Item 1), and add-water valve (Figure 100, Item 2) and allow water to drain.

7. Open all valves controlling water flow to optional equipment such as water meters.

NOTE

Apply thread sealant tape or thread sealant compound to the drain plug threads before installation.

8. When no more water comes from the tank drain(s) and water nozzles, install the water tank drain plug(s). Tighten the plug until snug.
9. Close the sight glass drain valves.
10. Close the drum wash-out valve (if equipped) (Figure 100, Item 1) and add-water valve (Figure 100, Item 2).
11. Pressurize water tank(s) to approximately 10—20 psi (69—138 kPa). Allow water to drain from wash-out hose.
12. Depressurize the water tank(s).

NOTE

Inspect hoses for low points that may retain water, even after the system has been drained. If a low spot is noted, have your service department reposition hoses to eliminate the low spot.

13. Open the drain petcock located at the lowest point in the supply hose (Figure 100, Item 4).

NOTE

If possible, drain and remove wash-out hose(s), and store hose(s) in the cab.

14. Open all water valves and make sure the water tank is depressurized.

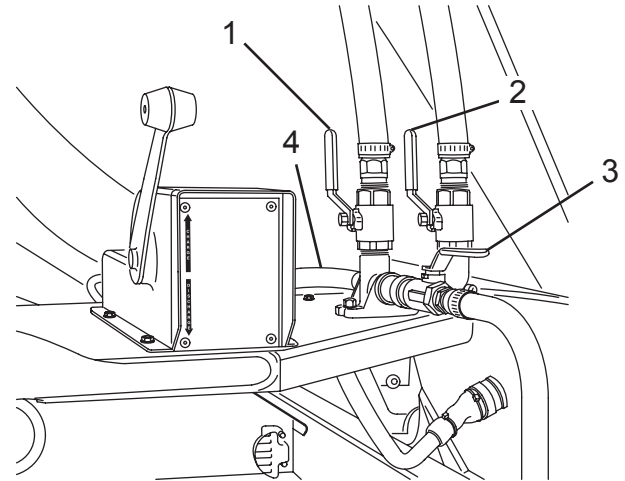

Figure 100

9.4 Filling the Main Tank

1. Depressurize the water tank.
2. Place the water supply hose in the water tank flopper valve (Figure 101, Item 1).

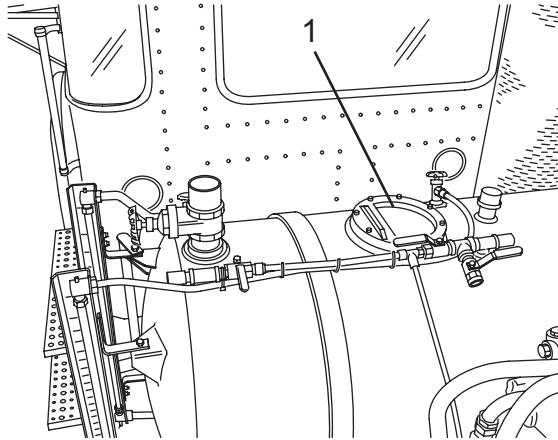

Figure 101

3. Open the water supply valve and fill the water tank.
4. Close the water supply valve.
5. Remove the supply hose from the valve.
6. Pressurize the water tank.
7. Inspect the water system for leaks.

WARNING

If damaged, corroded, or leaking, the water tank must be replaced with an OEM water tank from Revolution Concrete Mixers. Failure to comply may result in serious personal injury or death.

8. Depressurize the water tank before leaving for the job site.

9. Filling the Chemical Tank (Split Tank Option)

NOTE

Check with the batch plant operator for the proper type and amount of chemical required for the load.

The chemical tank is used to store additives needed to change the properties of the concrete. These additives may include plasticizers or retardants.

1. Depressurize the water tank.
2. Open the chemical tank gate valve (Figure 102, Item 1) and add the chemical through the inlet (Figure 102, Item 2).

3. Close the chemical tank gate valve.
4. Pressurize the water tank.
5. Inspect the water system for leaks.

 **WARNING**

If damaged, corroded, or leaking, the water tank must be replaced with an OEM water tank from Revolution Concrete Mixers. Failure to comply may result in serious personal injury or death.

6. Depressurize the water tank before leaving the job site.

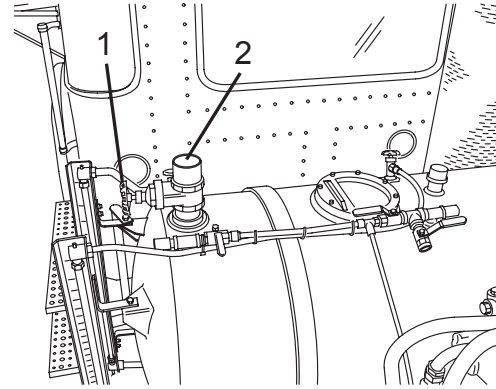

Figure 102

10.0 Water System - Pump

WARNING

Never attempt to repair the water tank. Never apply a weld procedure to a water tank. Replace water tank immediately if damaged. Failure to comply may result in serious personal injury or death.

The tank (Figure 103, Item 1) is not pressurized at any time. The water is drawn from the tank and pressurized by the air-powered diaphragm pump (Figure 103, Item 2).

The tank is equipped with one or more breathers (Figure 103, Item 3) that must be kept clean to ensure adequate water flow.

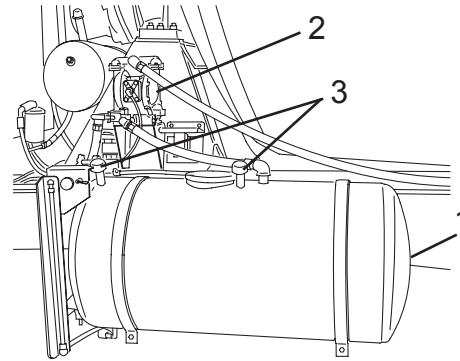

Figure 103

10.1 Pump Operation

The pump is powered by compressed air supplied by the chassis air compressor.

To operate the pump:

1. Start the truck and check to make sure the air pressure gauge is supplied with 100 psi (689 kPa) of pressure.
2. Close the purge valve (Figure 104, Item 1) at the pump inlet.
3. Open the main tank ball valve (Figure 104, Item 2) or chemical tank ball valve (Figure 104, Item 3) (if equipped) for the desired tank/water source.

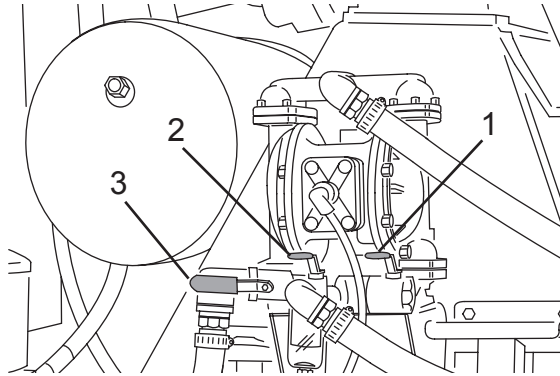

Figure 104

⚠ WARNING

Never pressurize a vessel not designed to be pressurized. Never modify water tank in any way. Failure to comply may result in serious personal injury or death.

NOTE

Trucks equipped with composite tanks will have the air pressure control valve mounted directly on the pump assembly. Turn off pump when not in use.

1. Turn the air pressure control valve (Figure 105, Item 1) to the PRESSURIZE position to start the pump.

To stop the pump, turn the air pressure control valve (Figure 105, Item 1) to the OFF position.

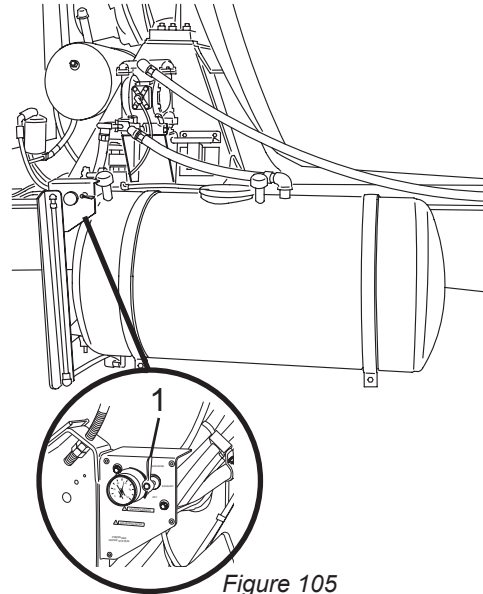

Figure 105

Operation

2. Open the upper wash-out valve (Figure 106, Item 1), “Add Water” valve (Figure 106, Item 2), or lower wash-out valve (Figure 106, Item 3) to activate the desired function.

SAFETY NOTICE

Be sure to drain the water system after each use when operating in temperatures below freezing. Failure to comply may cause damage to property or equipment.

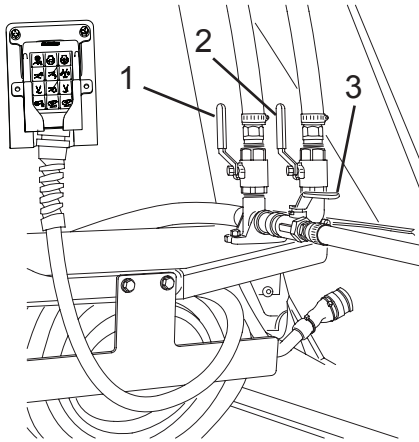

Figure 106

10.2 Filling the Water Tank

1. Turn the pump off by turning the air pressure control valve to the OFF position.
2. Place the water supply hose in the water tank flopper valve (Figure 107, Item 1) and fill the tank.

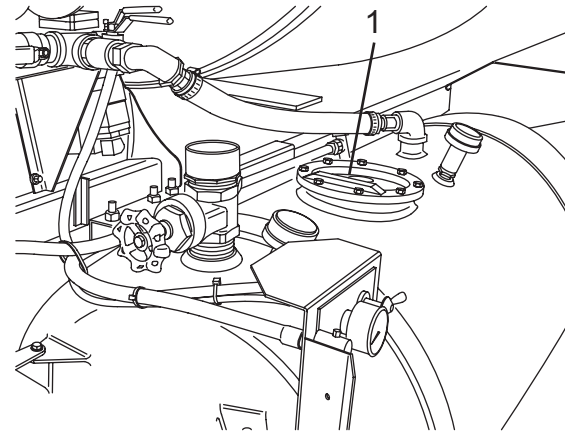

Figure 107

3. Close the water supply valve.
4. Remove the supply hose from the flopper valve.
5. Inspect the water system for leaks.

⚠ WARNING

If damaged, corroded, or leaking, the water tank must be replaced with an OEM water tank from Revolution Concrete Mixers. Failure to comply may result in serious personal injury or death.

10.3 Filling the Chemical Tank - Steel or Aluminum Tanks (Split Tank Option)

The chemical tank is used to store additives needed to change the properties of the concrete. These additives may include plasticizers or retardants.

NOTE

Check with the batch plant operator for the proper type and amount of chemical required for the load.

1. Turn the pump off by turning the air pressure control valve to the OFF position.
2. Open the chemical tank gate valve (Figure 108, Item 2) and fill the chemical through the inlet (Figure 108, Item 1).
3. Connect a water supply hose to the inlet (Figure 108, Item 1) and fill tank.

4. Close the water supply valve.
5. Remove the supply hose from the tank.
6. Inspect the water system for leaks.

⚠ WARNING

If damaged, corroded, or leaking, the water tank must be replaced with an OEM water tank from Revolution Concrete Mixers. Failure to comply may result in serious personal injury or death.

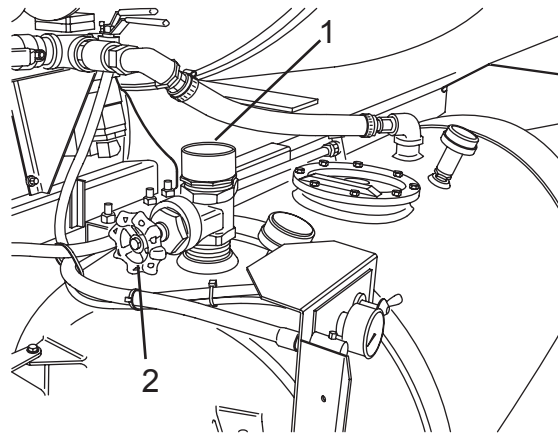

Figure 108

10.4 Draining the Water System

WARNING

Never allow the water from the tank to drain onto a public sidewalk or roadway. Water may cause the sidewalk or roadway to become slippery. Always drain the water system at a location designated by the job site manager or in compliance with your company policy. Failure to comply may result in serious personal injury or death.

SAFETY NOTICE

Be sure to drain the water system after each use when operating in temperatures below freezing. Failure to comply may cause damage to property or equipment.

NOTE

When draining the chemical tank, the contents should be drained into a properly marked container. The container should be stored for reuse, or the contents should be disposed of in compliance with all applicable regulations.

When operating in temperatures below freezing, the water system must be drained after each use.

1. Park the truck on a firm, level surface to allow proper drainage.

NOTE

The purge valve should be angled down slightly to permit proper drainage. If the valve is not positioned properly, have your service department reposition the valve/tee fitting assembly.

2. Open the main tank ball valve (Figure 109, Item 2) and chemical tank ball valve (Figure 109, Item 1) (if equipped).

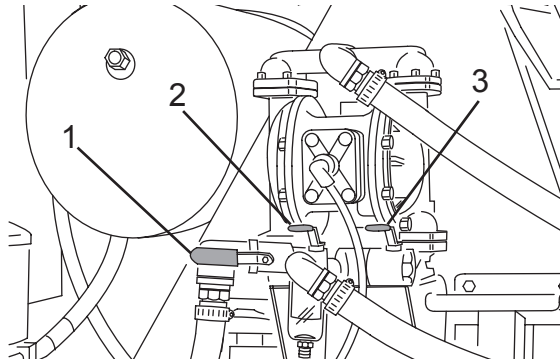

Figure 109

3. Remove the water tank drain plug(s) (Figure 110, Items 3 and 5), or open the drain valve(s) (if equipped).
4. Open the main tank (Figure 110, Item 4) and chemical tank (if equipped) (Figure 110, Item 2) sight glass isolator valves.
5. Open the sight glass drain valve(s) (Figure 110, Item 1).

NOTE

Apply thread sealant tape or thread sealant compound to the drain plug threads before installation.

6. When no more water comes from the tank drain(s), install the water tank drain plug(s) (Figure 110, Items 3 and 5). Tighten the plug(s) until snug.
7. Close the sight glass drain valve(s) (Figure 110, Item 4).

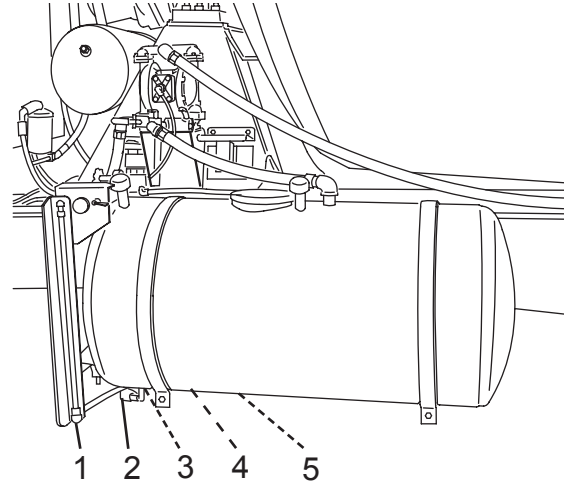

Figure 110

8. Start the truck and check to make sure the air pressure gauge is supplied with 100 psi (689 kPa) of pressure.

Operation

- Turn the pump on by turning the air pressure control valve to the PRESSURIZE position.
- Close the main tank ball valve (Figure 111, Item 2) and chemical tank ball valve (Figure 111, Item 1) (if equipped).
- Open the purge valve (Figure 111, Item 3).

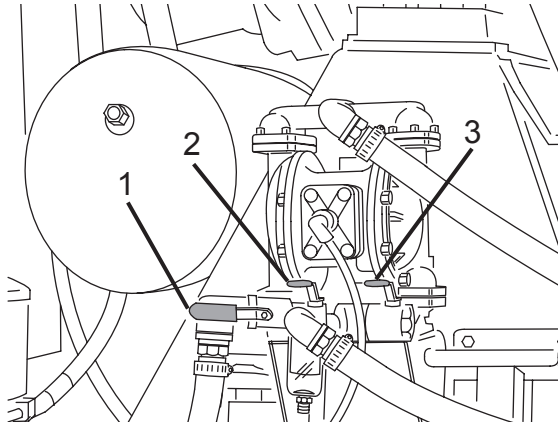

Figure 111

- Open wash-out hose valve (Figure 112, Item 3) at the rear of the Mixer and allow water to drain.
- Open wash-out valve (Figure 112, Item 1) and add-water valve (Figure 112, Item 2) and allow water to

drain through wash-out hose.

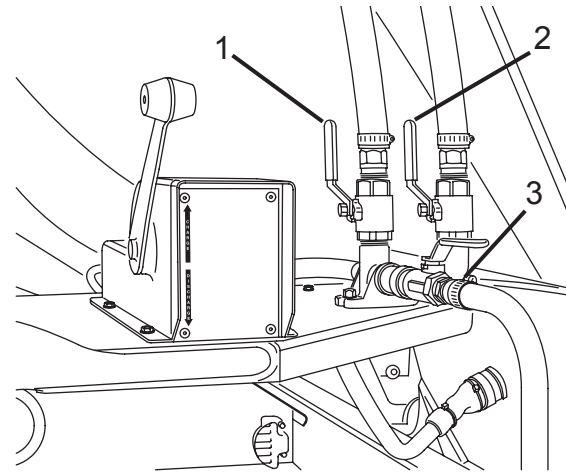

Figure 112

NOTE

Inspect hoses for low points that may retain water, even after the system has been drained. If a low spot is noted, have your service department reposition hoses to eliminate the low spot.

- Open the drain petcock located at the lowest point in the supply hose (Figure 113, Item 1).

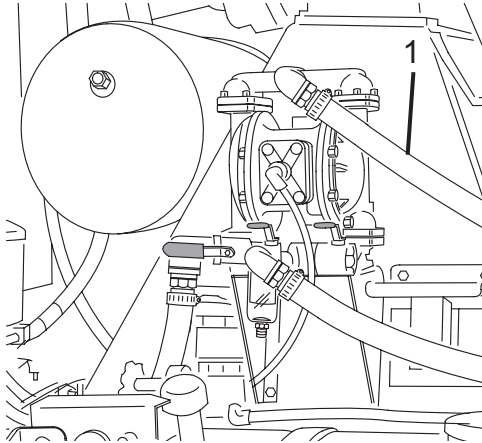

Figure 113

15. Turn the pump off by turning the air pressure control valve to the OFF position.

NOTE

If possible, drain and remove wash-out hose(s), and store hose(s) in the cab.

16. Open all water control valves and outlets and leave them open until the next use.

11.0 Water System Functions (Optional Equipment)

11.1 Washout Hoses

The washout hose provides a means for cleaning the mixer system after completing a delivery.

The Mixer is equipped with a hose (Figure 114, Item 5) at the rear of the Mixer. The flow to the hose is controlled by a ball valve (Figure 114, Item 1). The Mixer may also be equipped with additional (optional) hoses.

NOTE: The fins, charge hopper, collector, and other components on the rear of the Mixer can be washed from the ground using the washout hoses instead of standing on the platform.

11.1.1 Upper Washout Hose

An optional upper water hose (Figure 114, Item 4) is available to make cleaning of the charge hopper and drum easier.

The flow to the hose is controlled by a ball valve (Figure 114, Item 2) located at the rear of the Mixer.

11.1.2 Front Washout Hose

An optional front water hose is available to make cleaning of the front of the Mixer easier, or to use as

Operation

auxiliary water source on the pour site.

The flow to the hose is controlled by a ball valve located at the front of the Mixer.

11.1.3 Valve Drain

The valves may be equipped with a drain option. This feature automatically drains the water from the hose beyond the valve, through a small hole at the rear of the valves (Figure 114, Item 3).

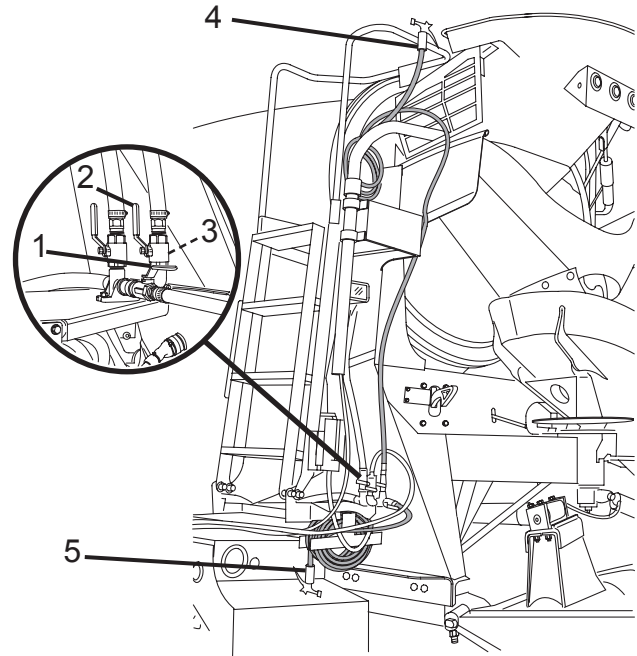

Figure 114

11.2 Auto Washout System for INSIGHT Mixer Systems

An optional auto washout system for Mixers equipped with INSIGHT System is available to make cleaning of the Mixer easier.

NOTE: If the auto washout system is active (the Start button has been pressed), the INSIGHT System takes over and charges the drum. Once the washout cycle is complete, or the Stop button has been pressed, the operator can resume charging the drum with the regular inputs (joystick, keypad, etc.).

1. Check all water lines are open and not damaged or leaking, and check the water level in the water tank.
2. On the INSIGHT System display screen, enter the Slump Screen (press on the gauges).
3. Select “Washout” (Figure 115).

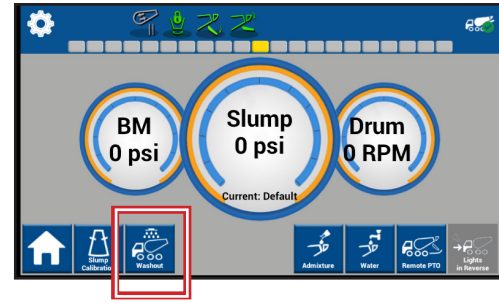

Figure 115

4. Select up to two different components of the Mixer to wash at a time (Figure 116). **NOTE:** Only two components can be washed at the same time.

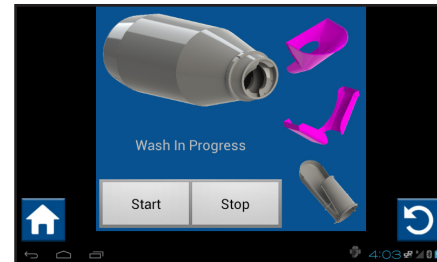

Figure 116

⚠ WARNING

Before starting the wash cycle, ensure the area around the mixer drum is clear of personnel. If the drum is not already turning, the drum will start turning in the charge direction when the wash cycle is started. Failure to comply may result in serious personal injury or death.

5. Press the Start button to begin auto wash down of the selected components. A “Wash In Progress” message will display on the screen (Figure 117).



Figure 117

6. When the wash down cycles have completed, a “Wash Complete” message will display on the screen (Figure 118).

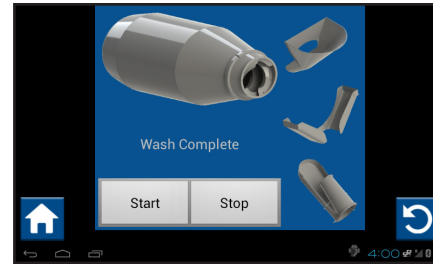

Figure 118

NOTE: The wash out cycle can be stopped by pressing the Stop button. This cancels the wash cycle; pressing Start will begin a new wash cycle.

NOTE: If desired, adjust washout time settings per component in the Slump Options screen (Figure 119). Access the Slump Options screen by pressing the Administrator button on the Home screen, then press the Options button. On the Diagnostics Menu screen that pops up, press the Slump button to enter the Slump Options screen.



Figure 119

11.3 Manual Washout System

Mixers may be equipped with an optional manual washout system that manually uses levers (Figure 120) to control the washing out of the hopper, collector, main chute, and drum/fin areas. This system may also be equipped with levers to control the add water feature and the upper washout hose. This manual washout system is available to make cleaning of the Mixer easier.

1. Check all water lines are open and not damaged or leaking, and check the water level in the water tank.
2. Turn on the water pump.
3. Move the lever from the closed position to the open position for the area you wish to washout.

4. When the washing out of that area is complete, move the lever from the open position to the closed position.

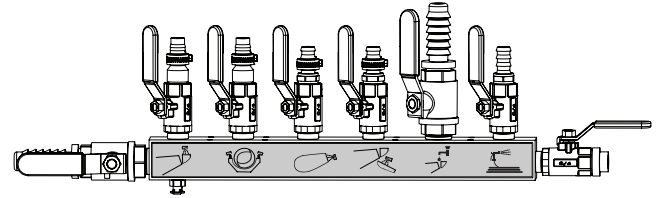

Figure 120

NOTE: More than one area may be washed out at the same time.

Operation

11.4 Spray Bar

Mixers may be equipped with an optional spray bar (Figure 121, Item 1). The spray bar allows water to be sprayed on the drum to cool the drum. The spray prevents the concrete from setting up prematurely in warm climates.

The flow of water to the spray bar is controlled by a ball valve (Figure 121, Item 2).

Do not use the spray bar during transit.

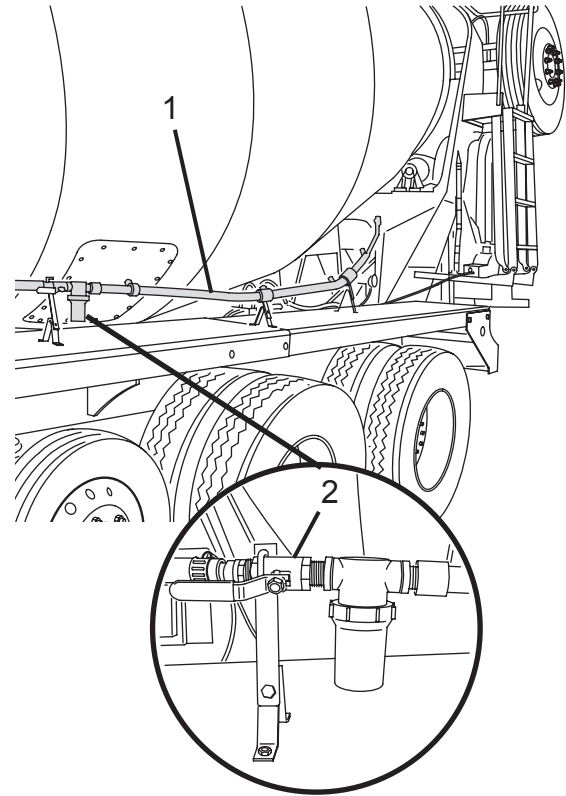

Figure 121

11.5 Water Meter Function

Mixer may be equipped with an optional water meter to allow monitoring of water used. There are four types of meters available: Precision, BR Industries, GPI®, and Signet.

11.5.1 Precision Water Meters

The Precision PMM™ water meter (Figure 122, Item 4) is installed directly in the water supply line to monitor the amount of water used.

The meter has a build-in register that is protected by a cover. The register records the amount of water used.

The counter records the number of gallons used to 1/10 of a gallon (0.4 liter).

To read the meter:

1. Before discharging water, record the counter reading and the position of the sweep hands on the “10” and “1” (tenths of a gallon) counters:
 - a. Record the reading from the counter (Figure 122, Item 1), in this case 220 gallons (833 liters).
 - b. Add the reading from the sweep hand on the “10” counter (Figure 122, Item 2), in this case 1 gallon (3.8 liter).
 - c. Add the reading from the sweep hand on the “1”

(tenths of a gallon) counter (Figure 122, Item 3), in this case 0.1 gallon (0.4 liter). The actual reading of the meter is 221.1 gallons (836 liters).

2. Discharge water as needed until the desired amount of water is determined from the original meter reading.

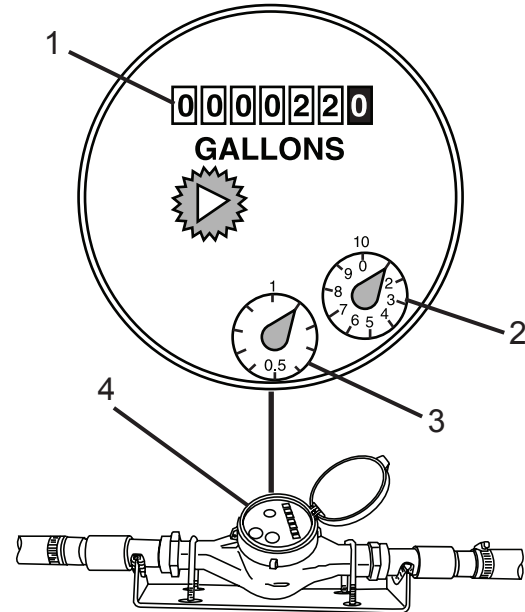

Figure 122

Operation

11.5.2 BR Industries (BM-25) Water Meter

The BM-25 meter is installed directly in the water supply line to monitor the amount of water used.

CAUTION

Do not exceed the manufacturer's temperature requirements per the water meter installed on your vehicle. Failure to comply may cause damage to property or equipment.

The meter has a display that is protected by a cover. The meter displays the amount of water used in gallons and liters.

To use the meter:

1. Slide the retaining strap (Figure 123, Item 1) to one side and open the cover (Figure 123, Item 2).

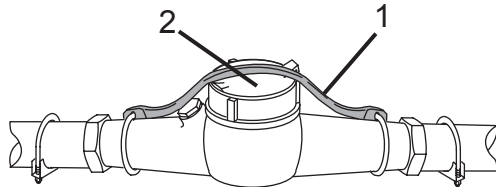

Figure 123

2. Reset the display by turning the collar (Figure 124, Item 1) counterclockwise until the pointer is aligned with "0".
3. Discharge water until the desired amount of water is displayed on the meter.

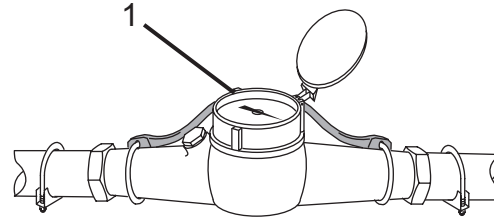

Figure 124

4. Close the cover (Figure 123, Item 2) and secure using the retaining strap (Figure 123, Item 1).

11.5.3 GPI® Water Meters

The GPI water meter (Figure 125, Item 1) is installed directly in the “Add Water” line to monitor the amount of water added to the mixer drum.

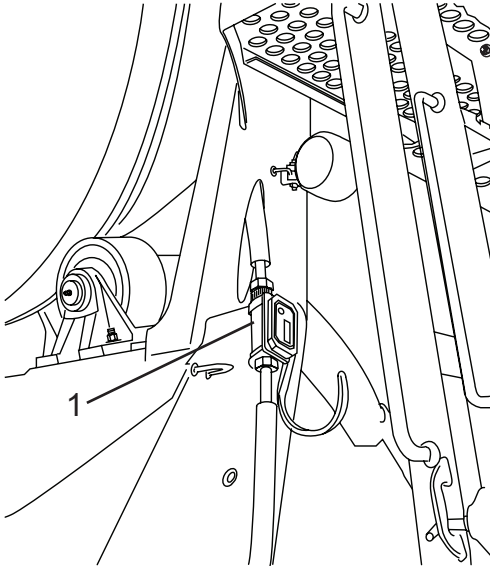

Figure 125

The meter is activated automatically when water flows through the meter. The meter can be manually activated by briefly pressing the DISPLAY button (Figure 126, Item 1).

The meter records two flow totals measured in gallons: “Batch” and “Cumulative.”

The “Batch” total (Figure 126, Item 3) is a record of flow used during a single use. When the meter is in “Batch” mode, “TTL1” (Figure 126, Item 2) will be displayed in the upper left corner of the meter display. This reading can be reset.

The “Cumulative” total is a record of continuous flow usage, from usage to usage. This is displayed as “TTL2” on the meter display. This setting cannot be reset; however, the display will reset to zero after the display reaches “9999.”

The meter is powered by two AAA alkaline batteries. If power is lost, the “Batch” and “Cumulative” totals will reset to zero.

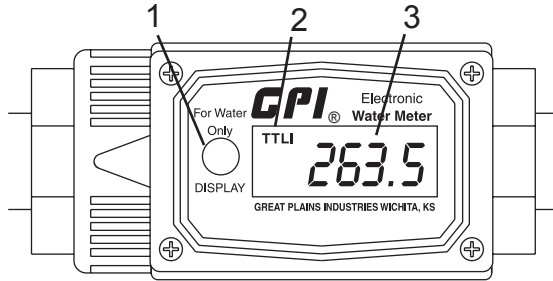

Figure 126

The meter has a power-saving feature, and will automatically shut off after one minute if no usage is detected.

To select display modes:

NOTE: On power-up, the meter will display the last total accessed during the previous use.

1. Activate the display by briefly pressing the DISPLAY button (Figure 127, Item 1).
2. Briefly press the DISPLAY button (Figure 127, Item 1) to change the total displayed - “Batch” mode (displayed as “TTL1”) or “Cumulative” mode (displayed as “TTL2”) (Figure 127, Item 2).

3. To reset the “Batch” total display, press and hold the DISPLAY button (Figure 127, Item 1) for three seconds.

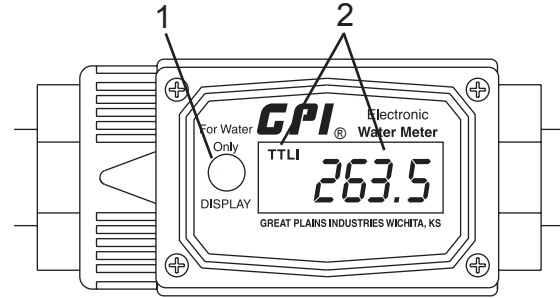

Figure 127

11.5.4 UFM Water Meters

For UFM water meters, the information for the amount of water added will be saved in the display mix log, recorded by time and date.

To use the meter:

1. Before discharging, press the reset switch (Figure 128, Item 1) to reset the counter display (Figure 128, Item 2).
2. Discharge water as needed until the desired amount of water is displayed.

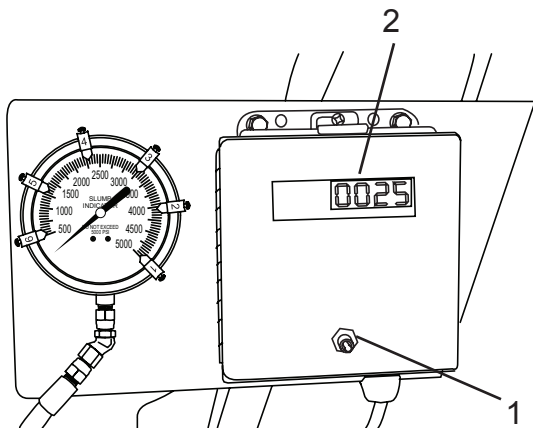

Figure 128

12.0 Optional Equipment

12.1 Hydraulic Fold-over Chute

The hydraulic fold-over toggle switch (Figure 129, Item 1) enables the operator to fold or unfold the fold-over chute (Figure 129, Item 2) using a hydraulic cylinder.

WARNING

Crush Hazard. Do not let persons, other than the driver, handle the chutes, unfold the fold-over, and/or remove extension, or stow and secure the extensions for transit. Keep hands away from chute hardware where the chutes connect. Never stand in the path of the chute as it is being unfolded or while in use. Failure to comply may result in serious personal injury or death.

CAUTION

Do not move vehicle with fold-over chute extended and chute extensions installed unless actively discharging concrete at job site. Failure to comply may cause damage to property or equipment.

Operation

To unfold the chute:

1. Position the chute so that there is sufficient room behind the chute. Lock the main chute using the manual chute lock or the optional chute air lock.
2. Remove the fold-over retaining chain.
3. Press and hold the fold-over toggle switch (Figure 129, Item 2) until the fold-over chute (Figure 129, Item 1) is fully seated against the main chute.
4. Release the switch.

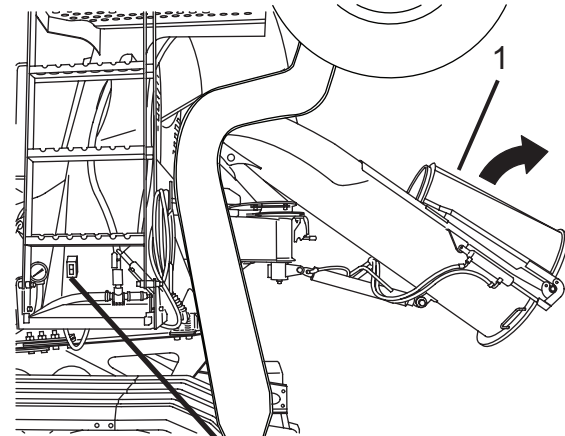

To fold the chute:

1. Press and hold the fold-over toggle switch (Figure 129, Item 2) until the fold-over chute (Figure 129, Item 1) is fully seated against the main chute.
2. Release the switch.
3. Secure the fold-over chute to the main chute with the retaining pin.
4. Stow and lock the main chute using the manual chute lock or the optional chute air lock.

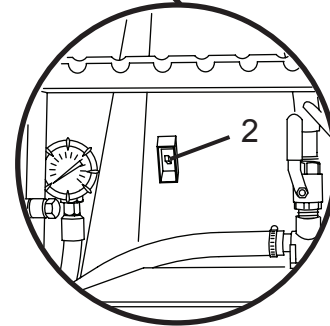

Figure 129

12.2 Chute Assist

The fold-over chute assist operates on a manual pulley to lower the fold-over chute into position.

To unfold the chute:

1. Unlatch the securing hook.
2. Grip the fold-over chute using the correct hand-holds (Figure 130).
3. Slowly lower the chute into operation position (Figure 131).

To fold the chute:

1. Grip the fold-over chute using the correct hand-holds (Figure 131).
2. Slowly raise the chute into stored position (Figure 132).
3. Latch the securing hook.

NOTE: The securing hook needs to be latched on the hand hold of the fold-over chute.

WARNING

Crush Hazard. The chute assist has pinch points between the main chute and the fold-over chute. Keep hands away from chute hardware where chutes connect. Keep hands away from the pulley system. Failure to comply may result in serious personal injury or death.

WARNING

Crush Hazard. Do not let persons, other than the driver, handle the chutes, unfold the fold-over, and/or remove extension, or stow and secure the extensions for transit. Keep hands away from chute hardware where the chutes connect. Never stand in the path of the chute as it is being unfolded or while in use. Failure to comply may result in serious personal injury or death.

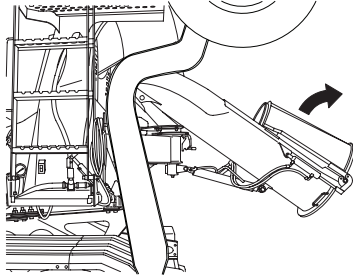

Figure 130

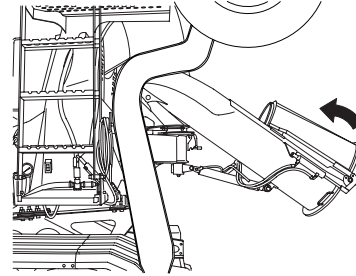

Figure 132

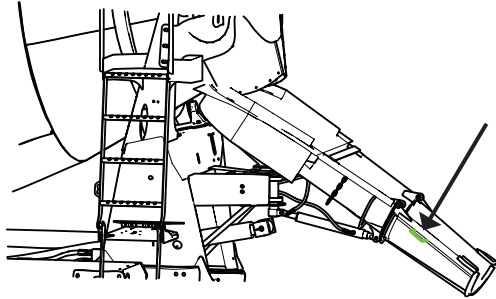

Figure 131

12.3 Hydraulic Chute Swing

The hydraulic chute swing option (Figure 133, Item 1) allows the operator to move the discharge chute from the standard in-cab control keypad or rear pendant keypad.

To engage the chute swing option:

1. Release the manual chute lock (Figure 133, Item 2).
2. Release the chute air lock.
3. Press the CHUTE SWING LEFT or RIGHT buttons on either the standard in-cab control or rear pendant to engage the chute swing drive. Release the button when the chute reaches the desired position.

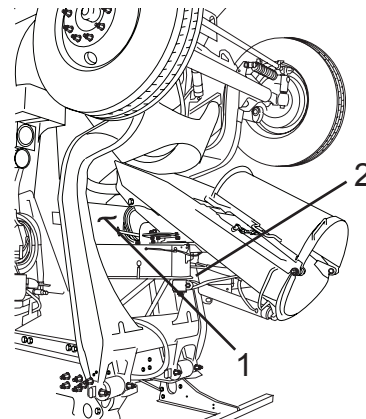

Figure 133

WARNING

Air chute lock is intended for use only on the job site. The manual chute lock should always be engaged during transport. Failure to comply may result in serious personal injury or death.

4. Engage the chute air lock.

12.4 Discharge Chute Vibrator Valve

When the chute vibrator valve (Figure 134, Item 1) is placed in the OPEN position, air pressure is supplied to the chute vibrator. This assists stiff slump concrete to flow down the chute.

SAFETY NOTICE

Operating the chute vibrator without concrete in the chute may cause damage to equipment.

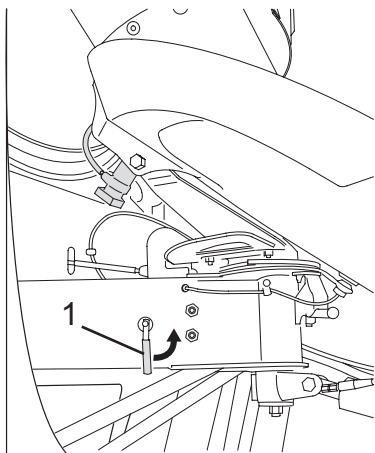

Figure 134

12.5 Chute Blockers

Discharge chute blockers prevent concrete or other debris from dropping off the main chute during transport. The chute blocker will automatically open when the fold-over chute is unfolded, and will close automatically when the fold-over chute is folded.

12.6 Fold-over Stop

The optional fold-over stop provides an additional margin of safety from pinch hazards when unfolding the fold-over chute.

As the chute is unfolded, the fold-over stop tab (Figure 135, Item 1) will make contact with the main chute, preventing the chute from slamming down against the main chute.

When the chute is raised, the fold-over stop will automatically release.

WARNING

Pinch Hazard. Remove hands, fingers, and any obstructions from the gap between the main and fold-over chutes before releasing the fold-over stop. Failure to comply may result in serious personal injury or death.

To release the fold-over stop:

1. Support the fold-over chute (Figure 135, Item 2).
2. Depress the handle (Figure 135, Item 3) until the stop tab (Figure 135, Item 1) clears the main chute, and lower the fold-over chute.

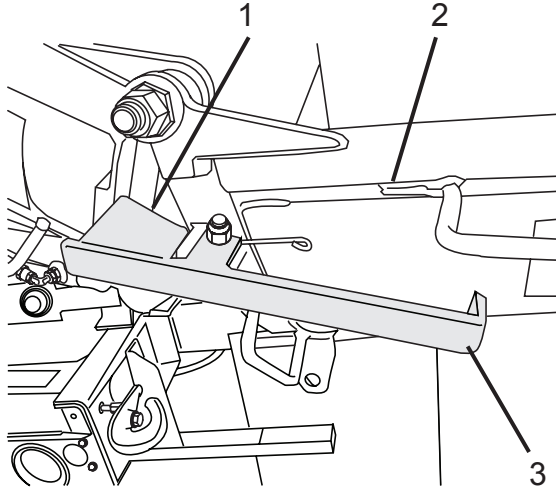

Figure 135

12.7 Flip-Up Charge Hopper

CAUTION

A raised hopper may cause overhead clearance problems. Always lower the flip-up hopper when not in use. Failure to comply may cause damage to property or equipment.

The flip-up charge hopper (Figure 136, Item 1) allows the charge hopper to be moved up to allow improved discharge of low slump concrete.

The flip-up charge hopper can be controlled either from the standard in-cab control keypad, or from the rear pendant keypad.

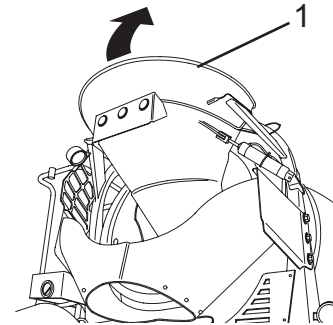

Figure 136

12.8 Swing Away Throat (SAT) Charge Hopper

The Swing Away Throat (SAT) charge hopper (Figure 137, Item 1) allows the lower section of the charge hopper to move back (away from the drum opening). This allows improved discharge of low slump concrete without raising the entire charge hopper.

The Swing Away Throat charge hopper can be controlled either from the standard in-cab control keypad, or from the rear pendant keypad.

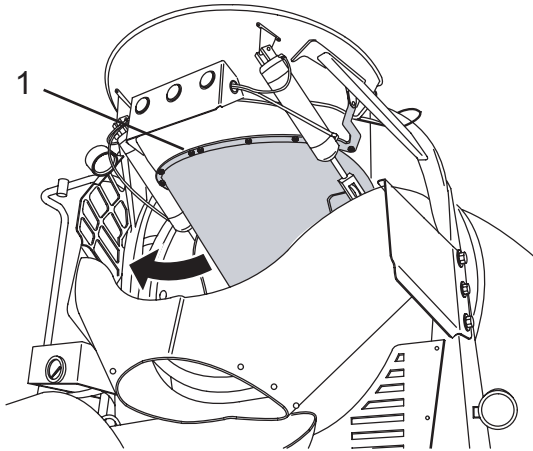

Figure 137

12.9 Right Hand Turn Audible Warning System

This optional system sends a audible message through a speaker mounted on the right hand front fender support any time the right hand turn signal is activated. The audible message is “CAUTION: VEHICLE TURNING RIGHT! ATENCION: VEHICULO GIRANDO A LA DERECHA!”

12.10 Lateral Protection Device

The rails on the lateral protection device (LPD) are designed to be removable for service of the vehicle. In addition, the bottom rail can be rotated up for increased ground clearance at the job site. **IMPORTANT:** The only time the LPD should be removed or rotated is when the vehicle is stationary. Return all parts of the LPD to their original positions before moving the vehicle.

Remove the LPD for Service

1. To remove the rails to perform service work on the vehicle, remove the pins and move the device out of the way.
2. Reinstall the device and pins to return the LPD to its original position before moving the vehicle.

Rotate the Bottom Rail of the LPD Up

1. To rotate the bottom rail of the lateral protection device up for increased ground clearance at the job site, hold onto the rail assembly and remove the **lower pin** from both sides of the bottom rail (Figure 138).

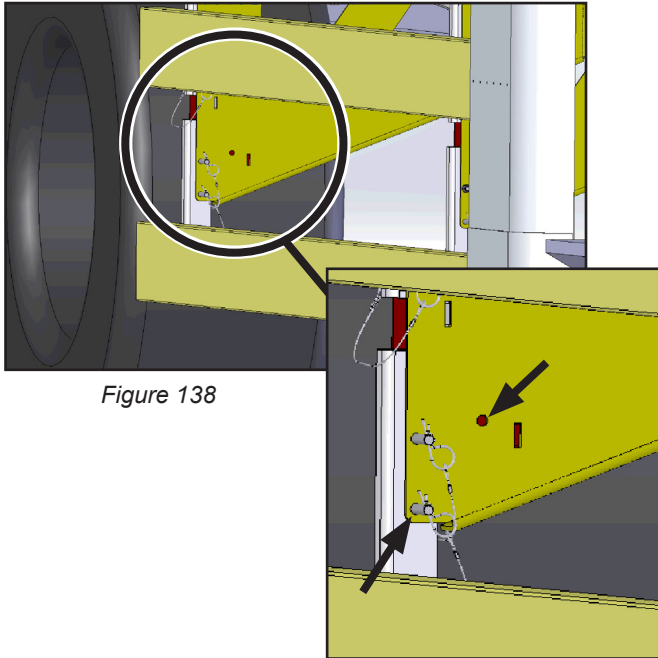

Figure 138

2. Rotate the bottom rail assembly up until the open holes on the LPD rail and the LPD gusset align (Figure 138).
3. Install each pin through the open holes in each bottom rail and gusset (Figure 139).

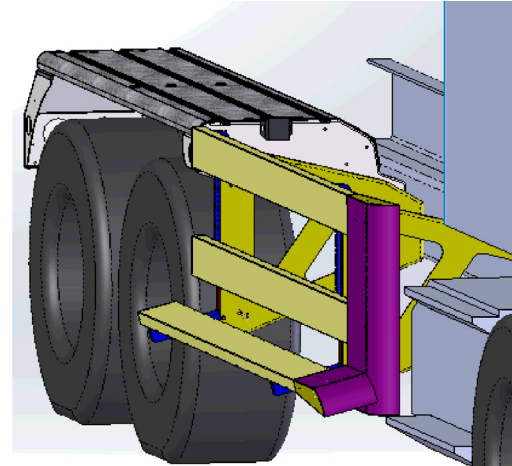



Figure 139



4. Reverse all steps to return the lower rail to its original position before leaving the job site.

Operation





12.11 Preco for INSIGHT Mixer System

The optional integrated Preco radar system will only work Mixers equipped with INSIGHT System. Refer to the Preco manual that came with the Mixer vehicle or visit Preco.com for a product manual (Side Defender or Sentry systems). The following images describe the screens that will display on the INSIGHT System display system when the Preco radar system is installed and operational. A stand-alone version (not integrated) is also available. Visit Preco.com for a product manual and more information.

Vehicle Command	Image on INSIGHT Display
Vehicle is placed in reverse and vehicle is approaching an object.	

Vehicle Command	Image on INSIGHT Display
Vehicle is placed in forward drive and vehicle is approaching an object.	
Vehicle left turn signal is activated and object is detected on the left.	
Vehicle right turn signal is activated and object is detected on the right.	

Vehicle Command	Image on INSIGHT Display
Proximity of vehicle to an object (front and rear object detection). NOTE: This is not a screen on the INSIGHT System display, but a legend to the color patterns shown when an object is detected.	 <p>No object detected</p> <p>Distance</p> <p>Object extremely close</p>

Vehicle Command	Image on INSIGHT Display
If a Preco sensor failed (missing or an error), a screen will display on the INSIGHT System display system with the failure condition.	 <p>Missing Sensor</p>  <p>Front/Rear</p>  <p>Side</p> <p>Sensor Error</p>  <p>Front/Rear</p>  <p>Side</p>

Operation

12.12 Concrete Slump Meter

NOTE

The location of the concrete slump meter may vary.

The concrete slump meter (Figure 140, Item 1) indicates the slump of the concrete by reading the hydraulic pressure required to rotate the drum. This pressure remains reasonably constant for a wide range of load sizes, the only requirement being that the mixing blades be fully covered.

The hydraulic pressure required to rotate the drum at a specific slump will vary because of different drum size, age, and drive ratios. This requires the slump meter to be calibrated for each Mixer.

NOTE

The concrete should be thoroughly mixed before a slump reading is taken from the slump meter.

The slump meter is calibrated by positioning pointers (Figure 140, Item 2) that are marked in inches of slump around the circumference of the hydraulic gauge. The pointers indicate the pressure that is required to rotate the drum at a given slump (See 12.12.1 Setting the Mechanical Concrete Slump Meter.)

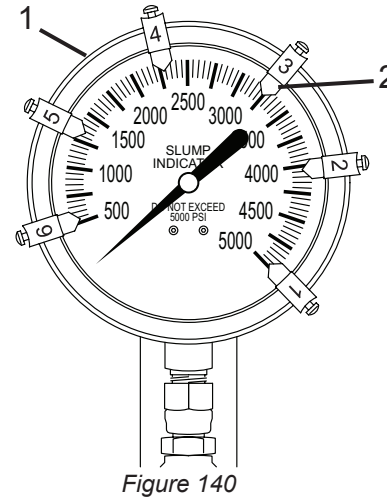

12.12.1 Setting the Mechanical Concrete Slump Meter

To calibrate the slump meter:

1. Load the drum with the normal full load of concrete at a slump that is less than the driest point you wish to read on your indicator, for example, 3”.

NOTE

To accurately calibrate the slump meter, the concrete must mix for at least 40 revolutions before setting the pointer.

2. Add water to the concrete until a slump reading of 3” is obtained when the concrete is fully mixed. Check the slump using a standard slump cone test.
3. Run the Mixer in the CHARGE direction with the truck engine at idle RPM. The drum must be mixing when reading the indicator.
4. Loosen the locking screw (Figure 141, Item 1), and move the 3” indicator (Figure 141, Item 2) to match the tip of the indicator needle. Tighten the locking screw.
5. Add water and test for 4”, 5”, and 6” of slump in the same manner.

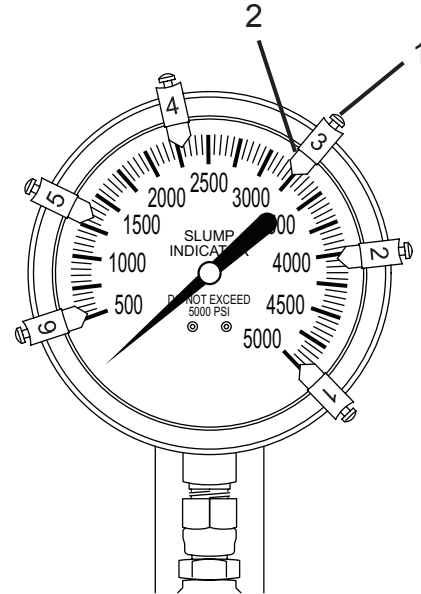

Figure 141

Operation

12.12.2 Setting the Digital Concrete Slump Meter for INSIGHT System Only

Digital slump meter must be calibrated individually on each truck upon delivery and periodically thereafter. The Slump Calibration screen is used to load and save slump calibrations. These values are then used for the inch readouts for the Slump gauges on the Drum and Slump screens.

1. Touch the Slump Calibration icon to enter the Slump Calibration screen (Figure 142).
2. Touch the “Inches” (Figure 142, Item 1) or “PSI” (Figure 142, Item 2) text box to bring up the on-screen keyboard to enter in and change the value.
3. Touch in the “profileName1” text box to name the profile that is to be saved.
4. Press the “Save” button to save the profile.
5. Follow the prompts on the screen to navigate to the next box and save the profile.

NOTE: If you enter an incorrect value in the text box, the box will turn red to signal the value needs to be changed.

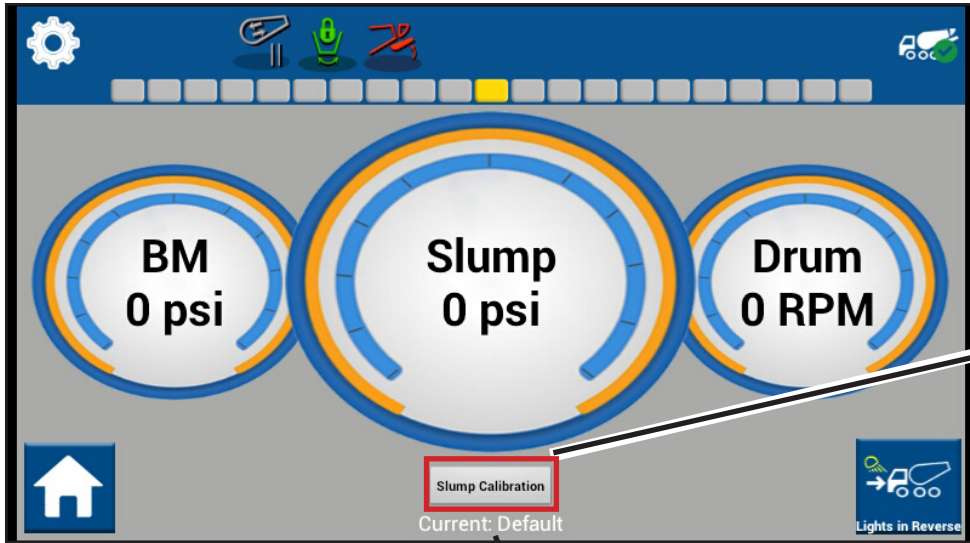

Figure 142

Displays Currently Selected Slump Profile

Operation

12.12.2.1 Loading a Slump Calibration Profile

1. Enter the Slump Calibration screen (Figure 143).
2. Touch the drop down menu and select the desired profile to be loaded.
3. Press the “Load” button to load the desired profile.

NOTE: The text boxes on this screen will update accordingly and the current Slump Profile name will be displayed on the Slump screen.

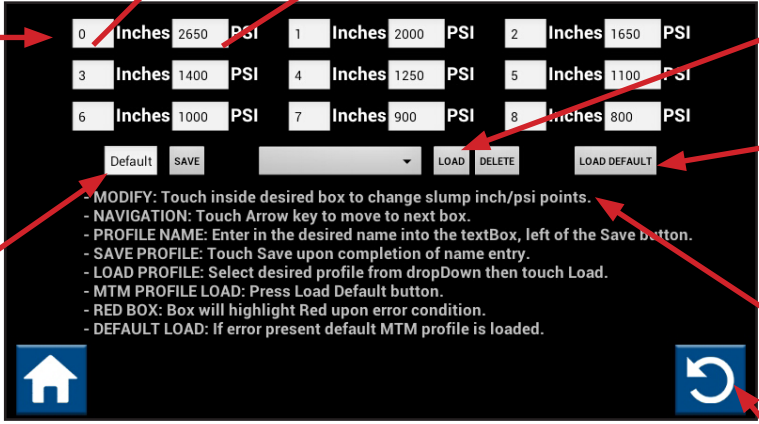

Item 1 Item 2

1st Inch/ Pressure Slump Pair

0	Inches	2650	PSI	1	Inches	2000	PSI	2	Inches	1650	PSI
3	Inches	1400	PSI	4	Inches	1250	PSI	5	Inches	1100	PSI
6	Inches	1000	PSI	7	Inches	900	PSI	8	Inches	800	PSI

Default SAVE [Dropdown] LOAD DELETE LOAD DEFAULT

MODIFY: Touch inside desired box to change slump inch/psi points.
 - NAVIGATION: Touch Arrow key to move to next box.
 - PROFILE NAME: Enter in the desired name into the textBox, left of the Save button.
 - SAVE PROFILE: Touch Save upon completion of name entry.
 - LOAD PROFILE: Select desired profile from dropDown then touch Load.
 - MTM PROFILE LOAD: Press Load Default button.
 - RED BOX: Box will highlight Red upon error condition.
 - DEFAULT LOAD: If error present default MTM profile is loaded.

Home Button Back to Slump Screen Button

Select Custom Profile and Load Button

Load Default Profile Button

Slump Calibration Overview Instructions

Name of New Slump Profile and Save Button

Figure 143

12.13 Central Lubrication Systems

Mixers may be equipped with one of several central lubrication systems. These systems allow mixer components to be lubricated from a central station.

Some systems have a manually-operated pump usually mounted in the cab.

NOTE

Lincoln Quicklube® system shown; other systems are similar.

Other central lubrication systems consist of a powered pump and reservoir unit (Figure 144, Item 1) mounted in the rear pedestal. This system can be set to automatically lubricate mixer components at predetermined intervals.

Each lubrication system has unique features and operating controls. Refer to the information supplied with the Mixer for specific operating, maintenance, and troubleshooting information.

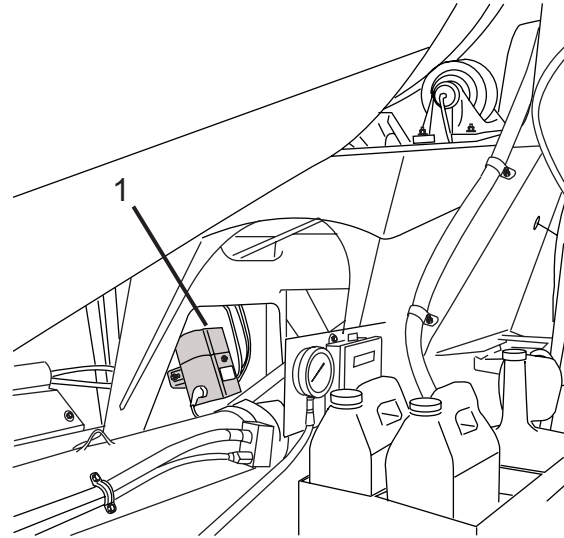

Figure 144

NOTE

The mounting location for the central lubrication system may vary depending on option and truck configuration.

The central lubrication may be equipped with an indicator light (Figure 145, Item 1). This light can be used to indicate operation and troubleshooting codes. Refer to the information supplied with the Mixer for specific information.

Each lubrication system has unique features and operating controls. Refer to the information supplied with the Mixer for specific operating, maintenance, and troubleshooting information.

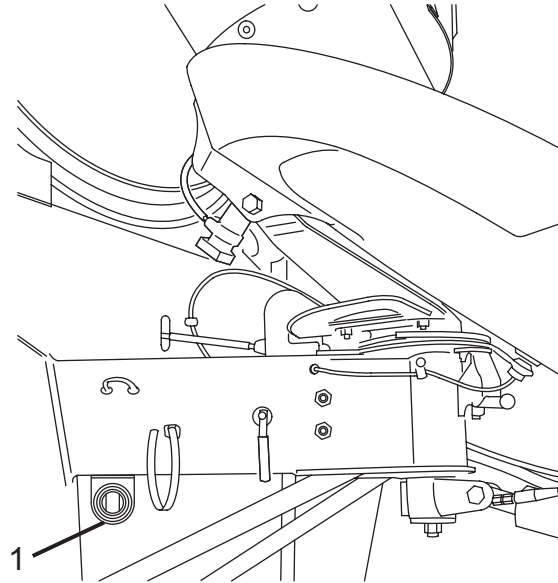

Figure 145

12.14 Wireless Transmitter

The Wireless Remote Control system consists of a transmitter, and a receiver that is connected to the mixer electronic control system.

12.14.1 Wireless Remote Control (Cab Console Version)

The transmitter (Figure 146, Item 1) when not in use is stored in the docking cradle (Figure 146, Item 2). The cradle will automatically charge the transmitter whenever the transmitter is placed in the cradle.

The transmitter is equipped with a battery-saving feature. If the transmitter is inactive for ten minutes, the transmitter will shut itself off (the receiver will then also shut off all outputs). Pressing any of the buttons momentarily before shut-down will reset the ten-minute timer.

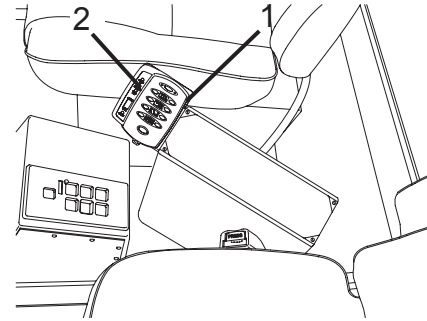

Figure 146

Operation

12.14.1.1 Control Buttons and Switches For INSIGHT System

Mixer functions can be operated by the control buttons on the transmitter and docking cradle (Figure 147), as well as the switches on the cab control console.

No.	Control	Normal Use or Reading
1	Power ON Button	Press to turn the system ON. ²
2	HOPPER UP/ DOWN Button	Press to raise or lower the charge hopper. ³
3	CHUTE LOCK/ UNLOCK Button	Press to engage the chute lock. Press the button again to disengage the chute lock.
4	CHUTE UP Button	Press and hold to raise the discharge chute.
5	CHUTE DOWN Button	Press and hold to lower the discharge chute.
6	E-STOP	To reset, press and hold button for 5 seconds.
7	Power OFF Button	Press to turn the system OFF

No.	Control	Normal Use or Reading
8	DRUM PAUSE Button	Press to stop drum rotation.
9	DRUM DISCHARGE Button ¹	Press and hold to drive the drum in the DISCHARGE (CCW) direction. Continue holding the button to increase drum speed. Release the button when the desired (or maximum) speed is obtained. The button can also be pressed and released to incrementally increase speed.
10	DRUM CHARGE Button	Press and hold to drive the drum in the CHARGE (CW) direction. Continue holding the button to increase drum speed. Release the button when the desired (or maximum) speed is obtained. The button can also be pressed and released to incrementally increase speed.

No.	Control	Normal Use or Reading
11	THROTTLE RETARD Button	Press to retard throttle/drum speed. (See Adjusting the Throttle Speed for more information.)
12	THROTTLE ADVANCE Button	Press to advance throttle/drum speed. (See Adjusting the Throttle Speed for more information.)

¹ If the DRUM DISCHARGE button is pressed while the drum is rotating in the Charge direction, the drum will slow before rotating in the Discharge direction.

² The chassis cruise control must be in the ON position, the parking brake must be applied, and the automatic transmission must be in NEUTRAL.

³ The function triggered by the switch will depend on the current state of that function. (Example: If the charge hopper is up, activating the switch will lower it.)

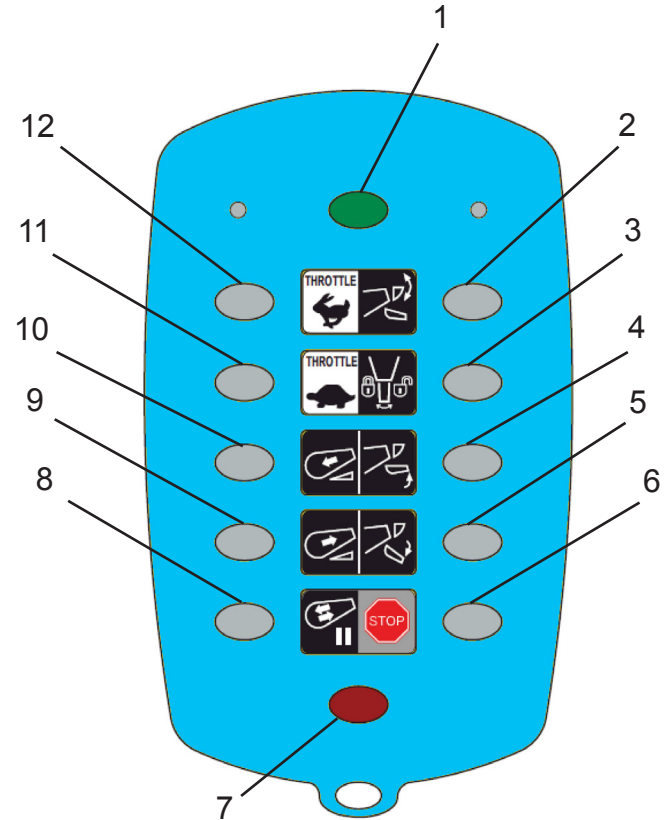

Figure 147

Operation

12.14.1.2 LED Indicators for INSIGHT System

The Battery Low (Figure 148, Item 1) and Active (Figure 148, Item 2) LED indicators on the transmitter are used to indicate the status of the transmitter.

Both of the LED indicators can display one of three colors (red, green, or yellow), and may operate in a solid, or in slow-flash or fast-flash display modes.

The combination of indicators activated, colors, and display modes are used to display transmitter status or display the fault code. (See Diagnostic Codes - Transmitter.)

No.	Control	Normal Use or Reading
3	BATTERY	The indicator is ON when the transmitter is installed in the docking cradle to indicate that the batteries are being recharged.

No.	Control	Normal Use or Reading
1	Battery Low LED	The indicator is ON when the batteries are low. The LED is also used to display diagnostic codes.
2	Active LED	The LED indicates that there is activity between the transmitter and receiver. The LED is also used to display diagnostic codes.

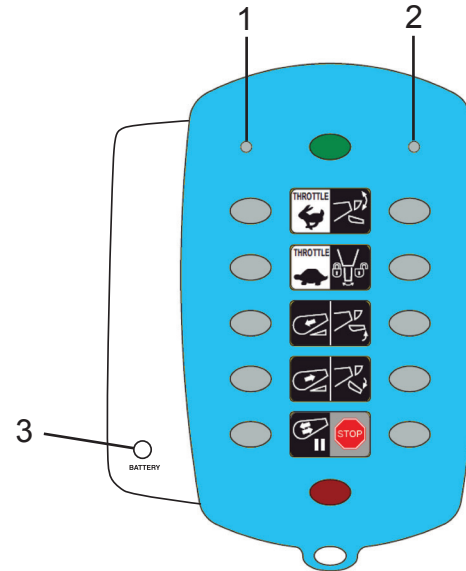

Figure 148

12.14.1.3 Control Buttons and Switches For Traditional Controls

NOTE

Transmitter buttons 4, 5, and 10 have alternate functions. The alternate functions are accessed by pressing and holding the green power button after the system is turned on.

Mixer functions can be operated by the control buttons on the transmitter and docking cradle (Figure 149), as well as the switches on the cab control console.

No.	Control	Normal Use or Reading
1	DRUM CHARGE Button	Press and hold to drive the drum in the CHARGE (CW) direction. Continue holding the button to increase drum speed. Release the button when the desired (or maximum) speed is obtained. The button can also be pressed and released to incrementally increase speed.

No.	Control	Normal Use or Reading
2	Power ON Button	Press to turn the system ON.
	SHIFT SELECT Button (Press and Hold)	Once the system has been activated, pressing and holding the button allows buttons 5, 6, and 7 to operate in the alternate function (lower icon).
3	DRUM DISCHARGE Button ¹	Press and hold to drive the drum in the DISCHARGE (CCW) direction. Continue holding the button to increase drum speed. Release the button when the desired (or maximum) speed is obtained. The button can also be pressed and released to incrementally increase speed.

Operation

No.	Control	Normal Use or Reading
4	THROTTLE RETARD Button ² (Primary Function)	Press to retard throttle/drum speed. (See Adjusting the Throttle Speed for more information.)
	HOPPER UP/DOWN Button (Alternate Function) ³	Press to raise or lower the charge hopper. ⁴
5	CHUTE DOWN Button (Primary Function)	Press and hold to lower the discharge chute.
	CHUTE SWING (RIGHT) Button (Alternate Function) ²	Press and hold to swing the discharge chute to the right.
6	CHUTE LOCK/ UNLOCK Button	Press to engage the chute lock. ³ Press the button again to disengage the chute lock.
7	Power OFF Button	Press to turn the system OFF. The drum will stop if it was rotating when the button was pressed, and the engine will return to idle.

No.	Control	Normal Use or Reading
8	DRUM STOP Button	Press to stop drum rotation. ³
9	CHARGE/ DISCHARGE Button (Located on Docking Cradle)	Press the CHARGE side of the switch to activate the drum rotation in CHARGE (CW) direction. Holding the switch down also increases drum speed in CHARGE (CW) direction or decreases drum speed in DISCHARGE (CCW) direction. Press the DISCHARGE side of the switch to activate the drum rotation in DISCHARGE (CCW) direction. Holding the switch down also increases drum speed in DISCHARGE (CCW) direction or decreases drum speed in charge (CW) direction.

No.	Control	Normal Use or Reading
10	CHUTE UP Button (Primary Function)	Press and hold to raise the discharge chute.
	CHUTE SWING (LEFT) Button (Alternate Function) ²	Press and hold to swing the discharge chute to the left.
11	THROTTLE ADVANCE Button	Press to advance throttle/drum speed. (See Adjusting the Throttle Speed for more information.)

¹ If the DRUM DISCHARGE button is pressed while the drum is rotating in the Charge direction, the drum will slow before rotating in the Discharge direction.

² The chassis cruise control must be in the ON position, the parking brake must be applied, and the automatic transmission must be in NEUTRAL.

³ To activate the alternate function, press and hold the Power ON/SHIFT SELECT button.

⁴ The function triggered by the switch will depend on the current state of that function. (Example: If the charge hopper is up, activating the switch will lower it.)

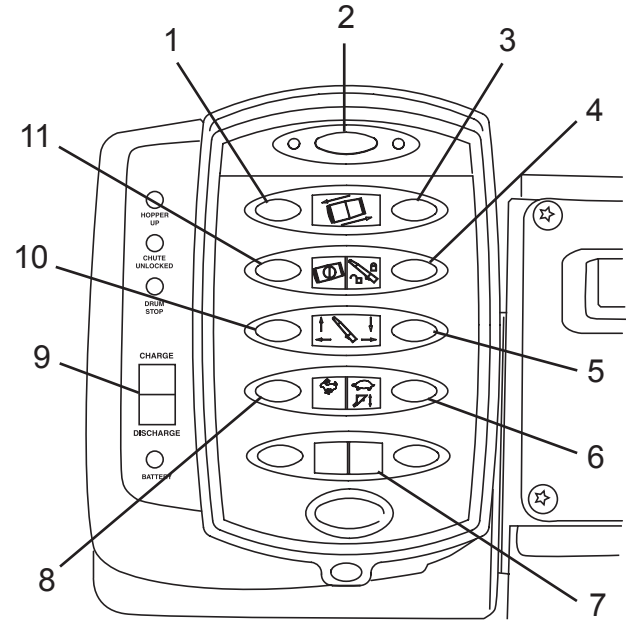

Figure 149

Operation

12.14.1.4 LED Indicators for Traditional Controls

The Battery Low (Figure 150, Item 1) and Active (Figure 150, Item 2) LED indicators on the transmitter are used to indicate the status of the transmitter.

Both of the LED indicators can display one of three colors (red, green, or yellow), and may operate in a solid, or in slow-flash or fast-flash display mode.

The combination of indicators activated, colors, and display modes are used to display transmitter status or display the fault code. (See Diagnostic Codes - Transmitter.)

No.	Control	Normal Use or Reading
1	Battery Low LED	The indicator is ON when the batteries are low. The LED is also used to display diagnostic codes.
2	Active LED	The LED indicates that there is activity between the transmitter and receiver. The LED is also used to display diagnostic codes.

No.	Control	Normal Use or Reading
3	BATTERY	The indicator is ON when the transmitter is installed in the docking cradle to indicate that the batteries are being recharged.
4	DRUM STOP	The indicator is ON when the drum rotation is stopped.
5	CHUTE UNLOCKED	The light indicates that the chute lock is unlocked.
6	HOPPER UP	The light indicates that the hopper is in the UP position.

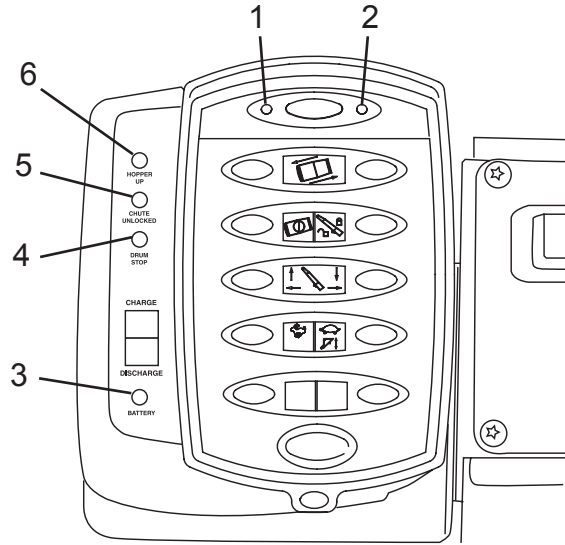

Figure 150

Operation

12.14.2 Cleaning the Transmitter

CAUTION

Do not clean the transmitter or receiver using high pressure. If water or other liquids get inside the transmitter battery compartment or receiver, immediately dry the unit. Remove the case and allow it to air dry before use. Failure to comply may cause damage to property or equipment.

Use a damp cloth to clean the transmitter unit after operation. Remove mud, dirt, concrete, etc. from the transmitter to prevent clogging of buttons.

12.14.3 Wireless Remote Control (Optional) Troubleshooting

12.14.3.1 Diagnostic Codes – Transmitter

1. The Battery Low (Figure 151, Item 1) and Active (Figure 151, Item 2) LED indicators on the transmitter are used to indicate the status of the transmitter (transmitter for Traditional Controls used for illustrative purposes).
2. Both of the LED indicators can display one of three colors (red, green, or yellow), and may operate in a solid, or in slow-flash or fast-flash display modes.

3. The combination of indicators activated, colors, and display modes are used to display transmitter status or display the fault code.

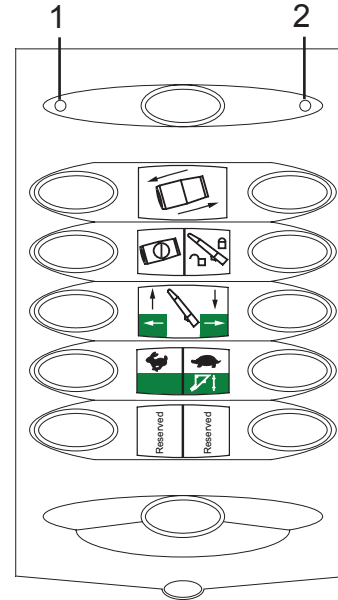

Figure 151

LED Indicator Activity	Status/Fault	Action
Battery Low LED: OFF Active LED: ON – Solid	Occurs whenever a function is pressed. Will also remain on momentarily during power-up.	None required – Normal operation.
Battery Low LED: OFF Active LED: ON – Slow Flash	Transmitter is in download mode.	Turn transmitter OFF and back ON again.
Battery Low LED: OFF Active LED: ON – Fast Flash	Transmitter is in operating mode.	None required – Normal operation.
Battery Low LED: ON – Slow Flash Active LED: ON – Fast Flash	Low battery.	Replace batteries. (See Battery Replacement– Plug and Play Version.) Recharge batteries by placing the transmitter in the docking cradle (cab control box version).
Battery Low LED: ON – Fast Flash (10 seconds) Active LED: OFF	Transmitter failure.	Requires shop service and repair.
Battery Low LED: ON – Slow Flash Active LED: ON – Slow Flash	Stuck button detected.	Turn power off. Depress all buttons several times to free the stuck button. Turn power on and check button functions. If problem cannot be cleared, shop service is required.

LED Indicator Activity	Status/Fault	Action
On Power Down – Only: Battery Low LED: ON – Slow Flash Active LED: ON – Slow Flash	Unit still under power; a stuck button may be detected.	Turn power off. Depress all buttons several times to free the stuck button. Turn power on and check button functions. If a problem cannot be cleared, shop service is required.
Battery Low LED: ON – Fast Flash Active LED: ON – Fast Flash	Transmitter is in configuration mode.	Requires shop service and repair.
Battery Low LED: ON – Solid Active LED: ON – Solid	Transmitter is downloading ID code.	Requires shop service and repair.

12.14.4 Receiver Locations

If the Mixer does not respond to commands from the transmitter, the receiver may need to be accessed to check diagnostic codes.

Depending on the version of the wireless remote installed, the location of the receiver will vary.

Cab Control Box Version: The receiver is located in the control box (cab control box) (Figure 152, Item 1).

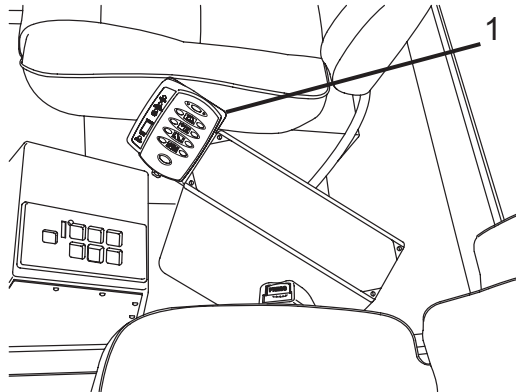

Figure 152

12.14.4.1 LED Indicators

LED indicators (Figure 153, Item 1) are used to indicate the operational status of the receiver. The LED indicators are also used to diagnose transmitter problems.

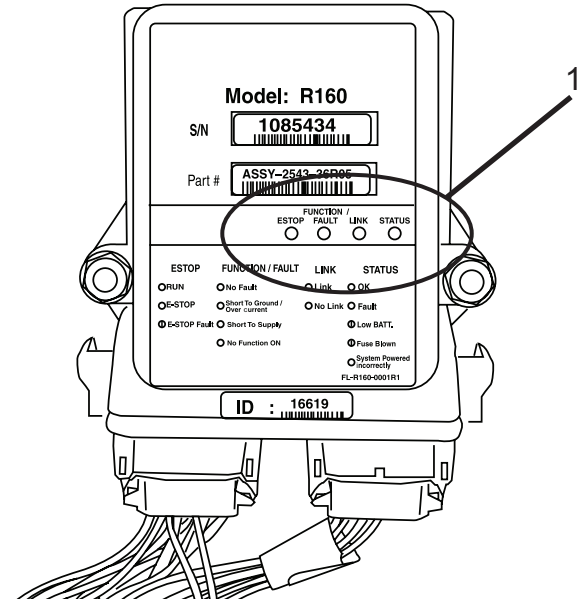

Figure 153

12.14.4.2 Normal Operation

LED Indicator Activity	Transmitter Status	Receiver Status
E-STOP: ON – Solid Red FAULT: OFF LINK: ON – Solid Red STATUS: ON – Solid Green	Transmitter: OFF	The receiver is operating properly.
E-STOP: ON – Solid Green FAULT: OFF LINK: ON – Green – Fast Flash STATUS: ON – Solid Green	Transmitter: ON	The receiver is operating properly.
E-STOP: ON – Solid Green FAULT: ON – Solid Green LINK: ON – Green – Fast Flash STATUS: ON – Solid Green	Transmitter: In operation	The receiver is operating properly.
E-STOP: ON – Solid Red FAULT: ON – Solid Green LINK: ON – Solid Red STATUS: ON – Solid Green	Transmitter: OFF	When a latched function is activated when the transmitter is turned off, the FAULT light will stay green. The receiver is operating properly. If the FAULT light is not green, service is required.

12.14.4.3 Fault Codes

NOTE: In some cases, the LED indicators will vary, depending on whether the transmitter is ON or OFF. See the transmitter status in the “Status/Fault” column in the chart in the pages below.

LED indicators (Figure 154, Item 1) are used to display the receiver fault codes.

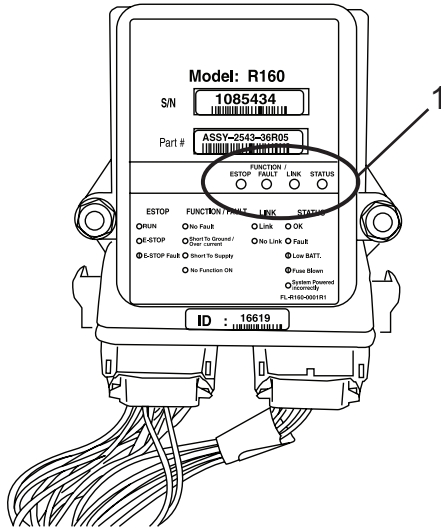

Figure 154

LED Indicator Activity	Status/Fault	Action
E-STOP: ON – Solid Red FAULT: OFF LINK: ON – Solid Red STATUS: ON – Solid Green	Transmitter: ON Receiver is not receiving a signal from the transmitter	Transmitter does not match receiver. Use correct transmitter. If transmitter matches receiver, the receiver requires shop service and repair.
E-STOP: ON – Solid Green FAULT: OFF LINK: ON – Green – Fast Flash STATUS: ON – Green – Slow Flash	Transmitter: ON A low battery condition has been detected	Replace batteries (Plug and Play Version). (See Battery Replacement – Plug and Play Version.) Recharge batteries (cab control box version). If fault code still displays after the batteries have been replaced, shop service and repair is required.
E-STOP: ON – Red – Slow Flash FAULT: OFF LINK: ON – Green – Fast Flash STATUS: ON – Solid Red	Transmitter: ON Short detected in E-STOP circuit	Requires shop service and repair.
E-STOP: ON – Solid Green FAULT: ON – Solid Red LINK: ON – Green – Fast Flash STATUS: ON – Solid Red	Transmitter: ON A short to ground or excessive current load has been detected	Requires shop service and repair.

LED Indicator Activity	Status/Fault	Action
E-STOP: ON – Solid Red FAULT: ON – Red – Slow Flash LINK: ON – Red – Fast Flash STATUS: ON – Solid Red	Transmitter: ON E-STOP output not properly connected	Requires shop service and repair.
E-STOP: ON – Solid Red FAULT: ON – Red – Slow Flash LINK: ON – Solid Red STATUS: ON – Solid Red	Transmitter: OFF A wiring short to the battery has been detected	Requires shop service and repair.
E-STOP: ON – Solid Red FAULT: OFF LINK: ON – Solid Red STATUS: ON – Solid Red	Transmitter: OFF Internal fault detected in receiver	Requires shop service and repair
E-STOP: ON – Solid Red FAULT: OFF LINK: ON – Solid Red STATUS: ON – Red – Slow Flash	Transmitter: OFF Blown fuse detected	Replace fuse. (See Fuse Functions.)
E-STOP: ON – Solid Green FAULT: OFF LINK: ON – Red – Fast Flash STATUS: ON – Red – Fast Flash	Transmitter: ON Set-up mode failure	Requires shop service and repair

Operation

LED Indicator Activity	Status/Fault	Action
E-STOP: ON – Solid Red FAULT: ON – Red – Slow Flash LINK: ON – Solid Red STATUS: ON – Alternating Red/ Green – Fast Flash	Transmitter: OFF Receiver powered incorrectly	Requires shop service and repair

13.0 Chassis Options

13.1 Pusher Axle

The auxiliary axle down force is controlled by regulated air pressure to the axle suspension air springs. The regulated air pressure is preset at the factory to a common pressure setting. Determine the actual regulated air pressure by driving the vehicle over a truck scale at the various weights the vehicle will be operated at up to the GVWR as shown on the Final Stage Manufacturer Label located on the driver's side cab doorjamb (see the Foreword). Adjust the regulated air pressure according to the auxiliary axle manufacturer's pressure/weight chart located in the cab information packet supplied with the vehicle. The air pressure gauge is located in the cab of the vehicle and may also be located outside of the cab.

Always follow your company's policies and procedures when adjusting the air pressure. If you have any questions, call Revolution Parts and Support at (855) 202-6491

NOTE

The following information is for auxiliary axles installed by Revolution Concrete Mixers. Refer to chassis manufacturer information for axles installed by the chassis manufacturer or a third party.

WARNING

Pinch Hazard. Do not lower pusher axle when the mixer is empty. Lower the pusher axle only as called out on the Bridgemaster® axle information placard. (See Bridgemaster® trailer functions.) Failure to comply may result in serious personal injury or death.

Pusher axle(s) (Figure 155, Item 1) are located in front of the rear drive axle.

Auxiliary axles use UP/DOWN buttons or switches (labeled PUSHER) to control the lower and lift function. The UP/DOWN buttons or switches are located on the in-cab keypads or on the digital control display in the cab.

The auxiliary axle down force is controlled by regulated air pressure to the axle suspension air bags. The regulated air pressure is preset at the factory. The

Operation

air pressure of the axle is displayed on an air gauge located in the truck cab. The air gauge may also be mounted outside of the cab.

To change the air pressure of an auxiliary axle, refer to the service manuals for your truck. Always follow your company's policies and procedures when adjusting the air pressure. If you have any questions, call Revolution Parts and Support at (855) 202-6491.

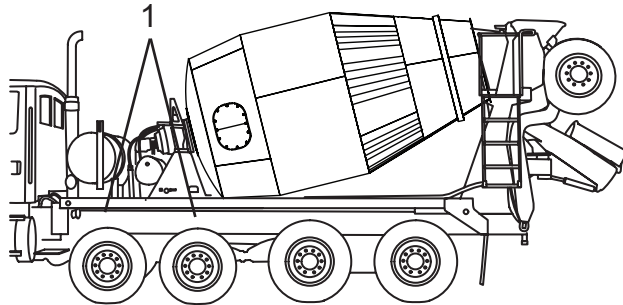

Figure 155

13.1.1 Raising or Lowering Pusher Axle for Revolution System Only

NOTE

Lower the auxiliary axles only when your load requires an auxiliary axle to distribute load weight. NEVER lower auxiliary axles when the truck is moving, or when the mixer is empty. The pusher axle air pressure is preset at the factory. Only your service department is authorized to adjust air pressure.

Revolution installed pusher axles are designed to lift when the truck is placed in reverse.

1. Bring the truck to a complete stop and set the park brake. (Refer to the Operator's Manual supplied by the chassis supplier for all parking procedures.)
2. Press the Pusher Axle function button (UP button is Item 1, and DOWN button is Item 2) on the standard in-cab keypad (Figure 156).

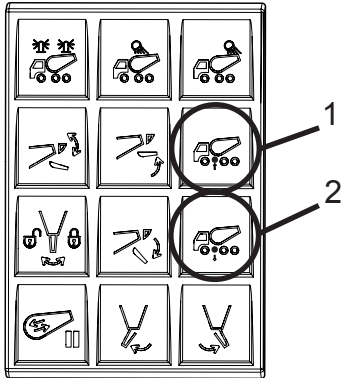

Figure 156

13.1.2 Lowering Pusher Axle for Traditional Controls Only

NOTE

Lower the auxiliary axles only when your load requires an auxiliary axle to distribute load weight. **NEVER** lower auxiliary axles when the truck is moving, or when the mixer is empty. The pusher axle air pressure is preset at the factory. Only your service department is authorized to adjust air pressure.

Revolution installed pusher axles are designed to lift when the truck is placed in reverse.

1. Bring the truck to a complete stop and set the park brake. (Refer to the Operator Manual supplied by the chassis supplier for all parking procedures.)
2. Push the pusher axle UP/DOWN switch to the DOWN position.
3. Resume normal operation.

1.0 Preventive Maintenance

The unit must be checked or inspected each day or before each new shift of operation. Report any deficiencies to your Maintenance Department for correction by skilled service personnel.

A yellow rectangular warning box with a black border. Inside, on the left, is a black triangle with a white exclamation mark. To the right of the triangle, the word 'CAUTION' is written in bold, black, uppercase letters.

Correct all identified deficiencies BEFORE operating the mixer. Failure to comply may cause damage to property or equipment.

1.1 DOT Pre-Trip

Perform pre-trip inspection of chassis and Mixer according to all federal, state, and local laws.

2.0 Preventive Maintenance Intervals

Performing preventive maintenance on your Mixer will prolong the life of its equipment, help prevent expensive downtime, and minimize the potential for problems arising during use.

The following Preventive Maintenance Chart summarizes the requirements to properly maintain your Mixer.

The chart specifies the recommended interval when each item should be performed.

Intervals are listed in calendar and hours-of-use increments. Maintenance should be performed at the increment that occurs first.

The preventive maintenance intervals listed under the **Service** group heading are the maximum days or hours allowed for each maintenance procedure. Continue to repeat the maintenance procedures at the listed intervals.

The Preventive Maintenance Chart identifies the responsibilities to be performed by both the operator and service personnel.

Some maintenance procedures are listed under both the **Operator** group heading and **Service** group heading.

The Daily Checks under the **Operator** group heading identify procedures that can be performed by either the operator or skilled service personnel.

NOTE

If the mixer is operated more hours per day or double-shifted, the maintenance interval must be adjusted accordingly.

The Preventive Maintenance Chart identifies the responsibilities to be performed by both the operator and service personnel.

Some maintenance procedures are listed under both the **Operator** group heading and Service group heading.

The Daily Checks under the **Operator** group heading identify procedures that can be performed by either the operator or skilled service personnel.

All intervals listed under the **Service** group heading must be performed by skilled service personnel. Refer to the product Service Manual for description of maintenance procedures.

Maintenance procedures are listed under the system of the Mixer that is affected.

Preventive Maintenance



LEGEND

- R Replace P Perform
- I Inspect L Lubricate
- T Torque C Clean

	Operator				Service			
	Number of Fittings	Daily Checks	Daily (10 Hours)	Weekly (50 Hours)	After First (100 Hours)	Monthly (200 Hours)	Semi-Annually (1250 Hours)	Annually (2500 Hours)

Lubrication - NLGI Grade 2 General Purpose EP Grease								
Drum Roller Bearings	2	L	L					
Remote Lubrication System	2	L	L					
Drum Roller Track (Brush On)		I	I					
PTO Shaft – Slip Joint	1			L				
PTO Shaft – U-Joints	2			L				
Main Chute Pivot	1			L				
Main Chute Manual Lock Shaft				L				
Drum Control Lever	2			L				
Bridgemaster Axle Hooks and Latch Pins		L						
Bridgemaster Axle Pivot Bushings	2				L			
Bridgemaster Axle Slack Adjuster	2	L						
Bridgemaster Axle S-Cam	2	L						

LEGEND

- R** Replace **P** Perform
I Inspect **L** Lubricate
T Torque **C** Clean

	Number of Fittings	Daily Checks	Operator	Daily (10 Hours)	Weekly (50 Hours)	After First (100 Hours)	Monthly (200 Hours)	Service	Semi-Annually (1250 Hours)	Annually (2500 Hours)
Bridgemaster Axle King Pins (Upper and Lower Fittings)	4		L							
Bridgemaster Axle Tie Rod Ends	2		L							
Hydraulic System										
Oil Level – Sight Glass		I/P	I/P							
Hydraulic Oil For Ambient Temps < 80°F (27°C) Use ISO Grade 68 For Ambient Temps > 80°F (27°C) Use ISO Grade 100						R		R		
Suction Filter (Rating B10 = 2) (50% efficient at 10 microns) Hydraulic oil at operating temperature: 2 to 5 in-hg, never read more than 10 in-hg						R		R		

Operation

LEGEND

- R** Replace **P** Perform
I Inspect **L** Lubricate
T Torque **C** Clean

	Number of Fittings	Operator				Service			
		Daily Checks	Daily (10 Hours)	Weekly (50 Hours)	After First (100 Hours)	Monthly (200 Hours)	Semi-Annually (1250 Hours)	Annually (2500 Hours)	
Suction Filter – Gate Valve Valve Open (A cable tie must be installed on the valve handle to prevent inadvertent closing of the valve)		I/P	I/P						
Hydraulic System and Components		I			I				
Hydraulic Hoses		I							
Hydraulic Pipes/Tubes		I							
ZF Gearbox									
Oil Level – Sight Glass		I/P	I/P						

LEGEND

- R** Replace **P** Perform
I Inspect **L** Lubricate
T Torque **C** Clean

	Number of Fittings	Operator			Service			
		Daily Checks	Daily (10 Hours)	Weekly (50 Hours)	After First (100 Hours)	Monthly (200 Hours)	Semi-Annually (1250 Hours)	Annually (2500 Hours)
Lubricant GL5 Spec. 85W-140 Gear Oil Capacity 4.2 gallons, 17 quarts (16.1 liters) Remove dipstick from oil fill port <div style="border: 1px solid black; background-color: #f96; padding: 2px; text-align: center;">⚠ WARNING</div> Pressurized oil may blow out of port when opened. Keep face and body away from port. Serious injury or death may occur.					R		R	
CML 12 Gearbox								
Oil Level – Sight Glass		I/P	I/P					
Lubricant GL5 Spec. ZF Ecofluid X Gear Oil Capacity 2.12 gallons, 8.5 quarts (8.044 liters) Remove dipstick from oil fill port <div style="border: 1px solid black; background-color: #f96; padding: 2px; text-align: center;">⚠ WARNING</div> Pressurized oil may blow out of port when opened. Keep face and body away from port. Serious injury or death may occur.						I*		

Operation



LEGEND

- R Replace P Perform
- I Inspect L Lubricate
- T Torque C Clean

	Operator				Service			
	Number of Fittings	Daily Checks	Daily (10 Hours)	Weekly (50 Hours)	After First (100 Hours)	Monthly (200 Hours)	Semi-Annually (1250 Hours)	Annually (2500 Hours)

* The lubrication level of the CML 12 gearbox should be checked monthly, but an oil change is not required throughout the normal service life. However, it is recommended to change the oil after 10,000 hours or 6 years.

Pneumatic System

Coalescing Filter		P	P			I/R		
Air Hoses and Fittings		I			I			

Electrical System

Lighting System		I			I			
Wire Harness		I			I			
Warning Alarms including audible back-up alarm and Bridgemaster Axle in-motion alarm		I/P	I/P					

Mixer Body and Components

Access Ladder(s) and Mounting Hardware		I						
--	--	---	--	--	--	--	--	--

LEGEND

- R** Replace **P** Perform
I Inspect **L** Lubricate
T Torque **C** Clean

	Number of Fittings	Daily Checks	Operator	Daily (10 Hours)	Weekly (50 Hours)	After First (100 Hours)	Monthly (200 Hours)	Service	Semi-Annually (1250 Hours)	Annually (2500 Hours)
Wheel Lug Nuts Tighten all lug nuts (including pusher axle and Bridgmaster axle) to 450 lbs-ft (610 N•m)				T						
Chute Extensions		I								
Optional Equipment										
Spray Bar Strainer (50 Mesh Strainer)				C/I ¹						
Chute Assist		I	I							
¹ Replace strainer as required.										
Operation										
Mixer Controls		P				P				
Safety Signs		I								
Bridgmaster Axle										
Axle Arm Welds				I						
Hook, Latch Pin and Pads		I								
Tire Pressure		I								

Operation



LEGEND

- R Replace P Perform
- I Inspect L Lubricate
- T Torque C Clean

	Number of Fittings	Operator				Service			
		Daily Checks	Daily (10 Hours)	Weekly (50 Hours)	After First (100 Hours)	Monthly (200 Hours)	Semi-Annually (1250 Hours)	Annually (2500 Hours)	
Tire Wear		I ¹							
Tire Lug and Studs		I							
Axle Hub Oil Level		I							
Axle Wheel Bearings								I/P	
Axle Rear Hub Seal		I							
Shocks and Mounting Hardware		I							
King Pins				I					
Tie Rod Ends				I					
Axle Stops				I					
¹ If excessive tire wear is noted, check axle toe adjustment and tire balance.									

3.0 Preventive Maintenance Daily Checks

3.1 Hydraulic System

SAFETY NOTICE

Perform your company's Lockout/Tagout procedure. If your company does not have a Lockout/Tagout procedure, follow OSHA 1910.147 and 1910.146 Confined Space as appropriate.

3.1.1 Hydraulic Oil Level

- **Daily Checks** – The oil level is checked by the operator or skilled service personnel.

NOTE

Check hydraulic oil level during start-up when the oil temperature is still cold.

Check the hydraulic oil level with all hydraulic components off and all hydraulic cylinders retracted.

NOTE

The shape and location of the hydraulic reservoir may vary. Round tank configuration shown. Square reservoirs may be mounted on the frame rails, in front of the radiator.

Check the hydraulic oil level at the sight gauge on the front of the reservoir. Hydraulic oil should be visible at the bottom of the sight gauge (Figure 157, Item 1).

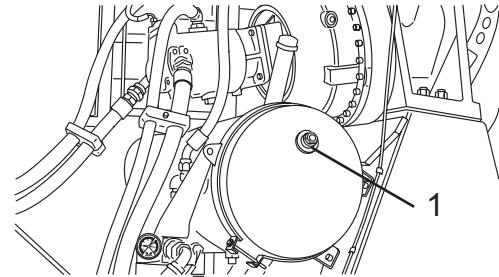

Figure 157

Operation

3.1.2 Hydraulic System and Components

- **Daily Checks** – The hydraulic system and components are inspected by the operator or skilled service personnel.

Inspect the hydraulic system and components for leaks and damage. Inspect around all fittings and connections. Look for any fresh puddles or drips under the Mixer.

3.2 Electrical System

SAFETY NOTICE

Perform your company's Lockout/Tagout procedure. If your company does not have a Lockout/Tagout procedure, follow OSHA 1910.147 and 1910.146 Confined Space as appropriate.

3.2.1 Lighting System

- **Daily Checks** – The lighting system is inspected by the operator or skilled service personnel.

Check to ensure that all exterior lights on the Mixer and chassis are functioning correctly. Replace any burned-out bulbs with the same type.

3.2.2 Warning Alarm System

- **Daily Checks** – The warning alarm system is inspected by the operator.

Check to ensure that all audible warning alarms on the Mixer are functioning correctly. Replace any audible warning alarms with the same type.

3.3 Pneumatic System

SAFETY NOTICE

Perform your company's Lockout/Tagout procedure. If your company does not have a Lockout/Tagout procedure, follow OSHA 1910.147 and 1910.146 Confined Space as appropriate.

3.3.1 Coalescing Filter

- **Daily Checks** – The coalescing filter is drained by the operator or skilled service personnel.
1. Locate the drain fitting (Figure 158, Item 1) on the bottom of the coalescing filter.
 2. Drain the filter by turning the drain fitting counterclockwise.
 3. After all moisture and contaminants have drained from the canister, turn the drain fitting clockwise.

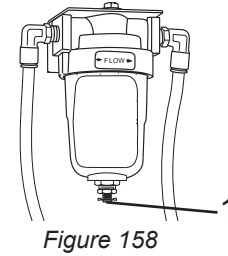

Figure 158

3.4 Mechanical System

SAFETY NOTICE

Perform your company's Lockout/Tagout procedure. If your company does not have a Lockout/Tagout procedure, follow OSHA 1910.147 and 1910.146 Confined Space as appropriate.

3.4.1 Mixer Components and Pedestals

- **Daily Checks** – The Mixer components should be inspected by the operator or skilled service personnel.

Inspect the pedestals and all components for binding, damage, and loose or missing parts.

Inspect access ladder(s) (Figure 159, Item 1) and mounting hardware for damage and/or loose or missing hardware.

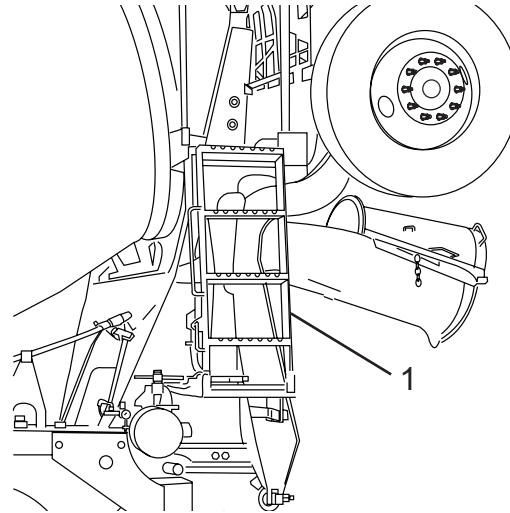

Figure 159

3.4.2 Water Tanks

- **Daily Checks** – The water tank(s) and components should be inspected by the operator or skilled service personnel.
1. Inspect the water tank(s) (Figure 160, Item 3) for leaks, cracks, breaks, or structural damage.
 2. Inspect hoses (Figure 160, Item 2) for leaks, cracks, or damage.
 3. Inspect sight glass(es) (Figure 160, Item 4) for cracks or damage.
 4. Check pump (Figure 160, Item 1) (if equipped) for proper operation.
 5. Check breathers (Figure 160, Item 5) (if equipped) to make sure they are free of debris.

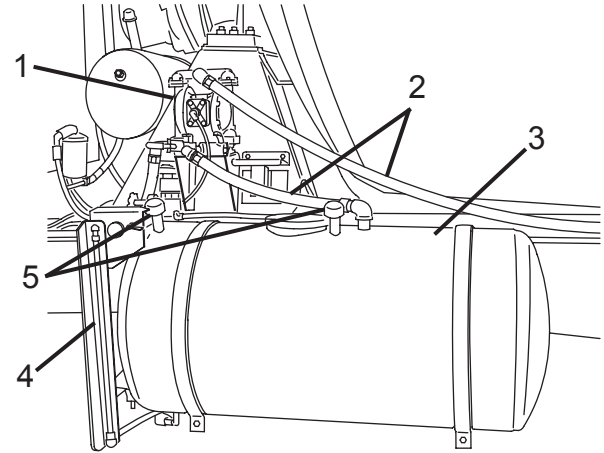

Figure 160

6. Check flopper valve (Figure 161, Item 1) for free movement, and make sure it seats properly.
7. Check valves (Figure 161, Items 2 and 3) to make sure they move freely.

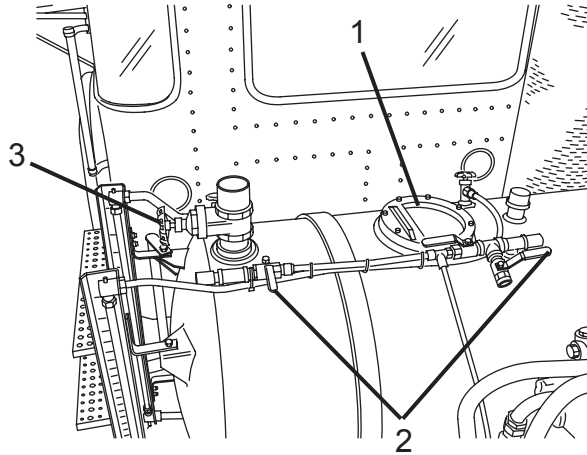

Figure 161

3.4.3 Chute Extensions

- **Daily Checks** – The chutes extensions should be inspected by the operator or skilled service personnel.

WARNING

Do not repair metal or composite chute extensions. Failure to comply may result in serious personal injury or death.

CAUTION

Never clean chute extensions by striking or chiseling. Failure to comply may cause damage to property or equipment.

DANGER

Flammable Hazard. Any urethane parts are flammable. Do not expose to an open flame or a temperature exceeding 220°F (104°C). Burning urethane parts produce toxic smoke/fumes during combustion. Failure to do so will result in serious personal injury or death.

1. Inspect the chute extensions for cracks, breaks, or structural damage. Replace chute(s) if any damage is noted.

3.4.4 Chute Assist

- **Daily Checks** – The chute assist should be inspected daily by the operator or skilled service personnel for wear, cable damage, pulley damage, and the correct tension.

WARNING

Crush Hazard. The chute assist has pinch points between the main chute and the fold-over chute. Keep hands away from chute hardware where chutes connect. Keep hands away from the pulley system. Failure to comply may result in serious personal injury or death.

WARNING

Crush Hazard. Do not stand under the chute while adjusting or testing the tension of the chute assist. Failure to comply may result in serious personal injury or death.

To adjust the tension of the chute assist:

1. Park the truck safely. (Refer to the Operator's Manual supplied by the chassis supplier for all shut-down and parking procedures.)
2. Apply the Lockout/Tagout procedure. (See Applying the Lockout/Tagout Procedure.)
3. Put the fold-over chute in the down/open position.
4. Loosen the nuts on the tension rod during the adjustment (Figure 162).

5. Use a pair of vice grips or other suitable tool to hold the tension tube and turn the tension rod clockwise to increase the tension or counterclockwise to reduce the tension (Figure 162).

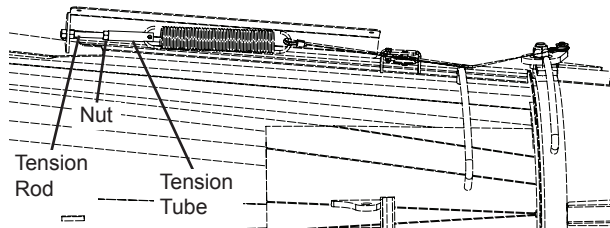

Figure 162

6. Divide the tension adjustment between both sides of the chute assist, making the right side and left side equal.
7. Adjust the tension so when the fold-over chute is in the UP/CLOSED position, the cable is taut and does not droop or sag.
8. Once the proper tension is achieved, apply Blue Loctite® and tighten the nuts to lock the adjustment.
9. Over extension of the spring beyond 22-1/4" will damage the spring.
10. Inspect the chutes and chute assist daily for wear, cable damage, pulley damage, and the correct

Preventive Maintenance

tension. Inspect and adjust as necessary, especially after the cables and springs stretch.

3.5 Standard (Steel) Drum

3.5.1 Standard (Steel) Drum Inspection

- **Daily Checks** – The mixer drum should be inspected by the operator or skilled service personnel.
1. Park the truck safely. (Refer to the Operator's Manual supplied by the chassis supplier for all shut-down and parking procedures.)
 2. Perform your company's Lockout/Tagout procedure. If your company does not have a Lockout/Tagout procedure, follow OSHA 1910.147 and 1910.146 Confined Space as appropriate.
 3. Raise the charge hopper.
 4. Inspect the interior of the drum for concrete build-up. Remove concrete as needed. (See Concrete Removal for removal information.)
 5. Check the discharge hopper-to-drip ring clearance (Figure 163, Item 1). Clearance should be 2 inches (51 mm) between the discharge hopper face and the drip ring, and no more than 1 inch (25 mm) radially around the drip ring.

6. Check the areas where the discharge hopper and drip ring meet for concrete build-up. Remove concrete as needed.

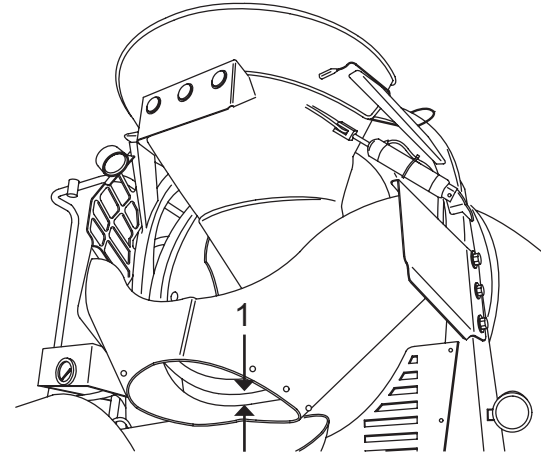

Figure 163

WARNING

Crush Hazard. Moving drum can crush you against debouncer. Keep yourself and tools clear of debouncer when drum turns. Failure to comply may result in serious personal injury or death.

7. Check the debouncer-to-drip ring clearance (Figure 164, Item 1), the clearance should be 3/8 to 1/2 inch (10 to 13 mm) at the closest point.

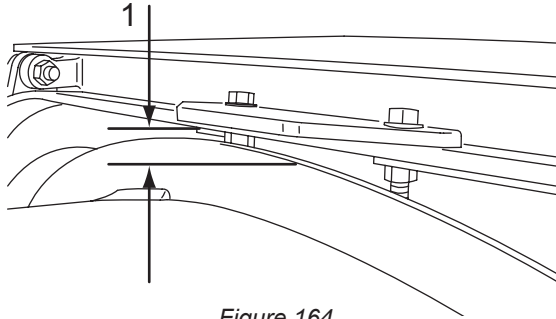

Figure 164

8. Check the drum flange bolt (Figure 165, Item 1) torque. (Refer to the Service Manual for torque values.) If a bolt turns during this check, that bolt must be removed and replaced with a new Grade 8 bolt.

NOTE

Grade 8 bolts can be purchased with or without a pre-applied threadlocker such as Loctite®. There are different torque values for bolts with and without a pre-applied threadlocker. Use the procedure that applies to your application.

Preventive Maintenance

New Grade 8 Bolt(s) **without** Pre-Applied Threadlocker:

- a. Clean the threads in the drum.
- b. Apply Red Loctite® to the threads of new Grade 8 bolts.
- c. Install and tighten the bolt(s) to the specified torque. (Refer to the Service Manual for torque value.)

New Grade 8 Bolt(s) **with** Pre-Applied Threadlocker:

- a. Clean the threads in the drum.
- b. Install and tighten new Grade 8 bolt(s) to the specified torque. (Refer to the Service Manual for torque value.)

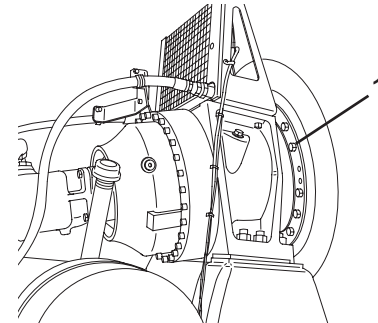

Figure 165

9. Lower charge hopper.

Preventive Maintenance

10. Remove your company's Lockout/Tagout procedure. If your company does not have a Lockout/Tagout procedure, follow OSHA 1910.147 and 1910.146 Confined Space as appropriate.

3.5.2 Concrete Removal

Refer to the Mixer Service Manual for concrete removal instructions.

3.6 Operation



WARNING

Crush Hazard. Be sure non-operating personnel are a safe appropriate distance from all areas of the mixer. Failure to comply may result in serious personal injury or death.

3.6.1 Mixer Controls

SAFETY NOTICE

Perform your company's Lockout/Tagout procedure. If your company does not have a Lockout/Tagout procedure, follow OSHA 1910.147 and 1910.146 Confined Space as appropriate.

- **Daily Checks** – The mixer controls are checked for proper operation by the operator or skilled service personnel.

Operate all functions to validate that they are operational. Verify that all indicator lights and alarms are operational.

3.7 Safety Decals

- **Daily Checks** – A complete walk around of the vehicle to inspect the safety decals should be performed every day before operation. If any of the safety decals are damaged, illegible, or missing, they must be replaced before operation.

The following safety decals are found on your concrete mixer. They warn of hazards related to the use of this equipment. Read and understand all safety decals before operating this equipment. All safety decals should be present and clearly readable at all times. If any safety decals on the equipment are not clearly readable, contact Revolution Concrete Mixers at (855) 202-6491 or www.streetsmartparts.com to order replacements. Use only Revolution replacement safety decals.

For information on any of the chassis safety decals, please contact the chassis manufacturer.

NOTE

Depending on the mixer configuration and optional equipment, the actual location of decals and/or placards may vary from the examples shown.

The table below contains part numbers for the individual safety decals.

NOTE

Specifications, appearance, and part numbers for safety decals are subject to change without notice.

No.	Part Number	Qty.	Comments
1	0214603	4	
2	1321144	2	
4	0129700	2	
5	0215072	2	
7	0215100	1	
8	0214504	1	

Preventive Maintenance

No.	Part Number	Qty.	Comments
9	Not Available Separately.	1	If needed, order part number 0214545.
10	1138174	1	
11	0155068	1	
12	1240555	1	
13	0215099	1	
14	0214515	1	
15	0215063	2	
16	9083.601930	2	
17	0215084	1	
18	0214717	1	
19	0215098	1	
20	0214672	2	
21	0215097	1	
22	0215060	4	
23	0115118	1	
24	1130173	2	
25	0214502	1	
26	1659441	1	
27	0214512	2	

Preventive Maintenance

No.	Part Number	Qty.	Comments
28	0214671	1	
29	0214724	2	
30	1130172	8	
31	1676092	1	
32	0215064	2	
33	1659440	3	
34	1676091	2	
35	1676090	1	
36	0215119	1	
37	0215023	1	
38	0115117	1	
39	0215021	1	
40	1533520	1	
41	1420547	1	
42	1676089	1	
43	1676093	3	
44	0129709	1	
45	1138173	1	
46	0214667	1	
47	0214666	1	

No.	Part Number	Qty.	Comments
48	0215095	1	
49	0215123	2	
50	0214513	1	
51	0215086	1	
52	0215058	1	
53	1138175	1	
54	1677580	1	
55	1326487	1	
56	0115100	1	
57	0214506	1	
58	0215057	1	
59	0215024	1	
60	0214648	1	
61	1139944	2	
62	TMMB	1	
64	0214618	1	
65	1225788	1	
66	1326014	1	
67	1241178	1	
68	1420592	1	

No.	Part Number	Qty.	Comments
69	1496869	1	
70	1597667	1	

3.7.1 Safety Decal and Placard Locations

3.7.1.1 Passenger Side Views

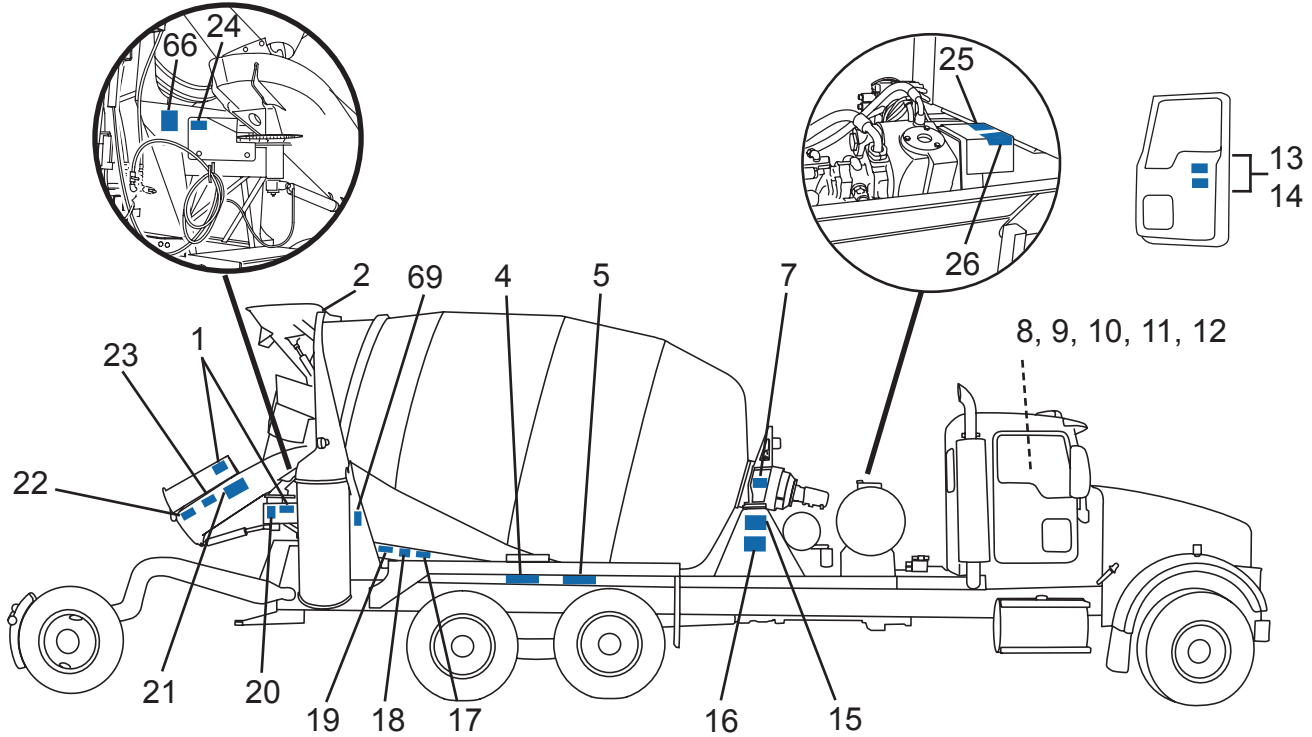

Figure 166

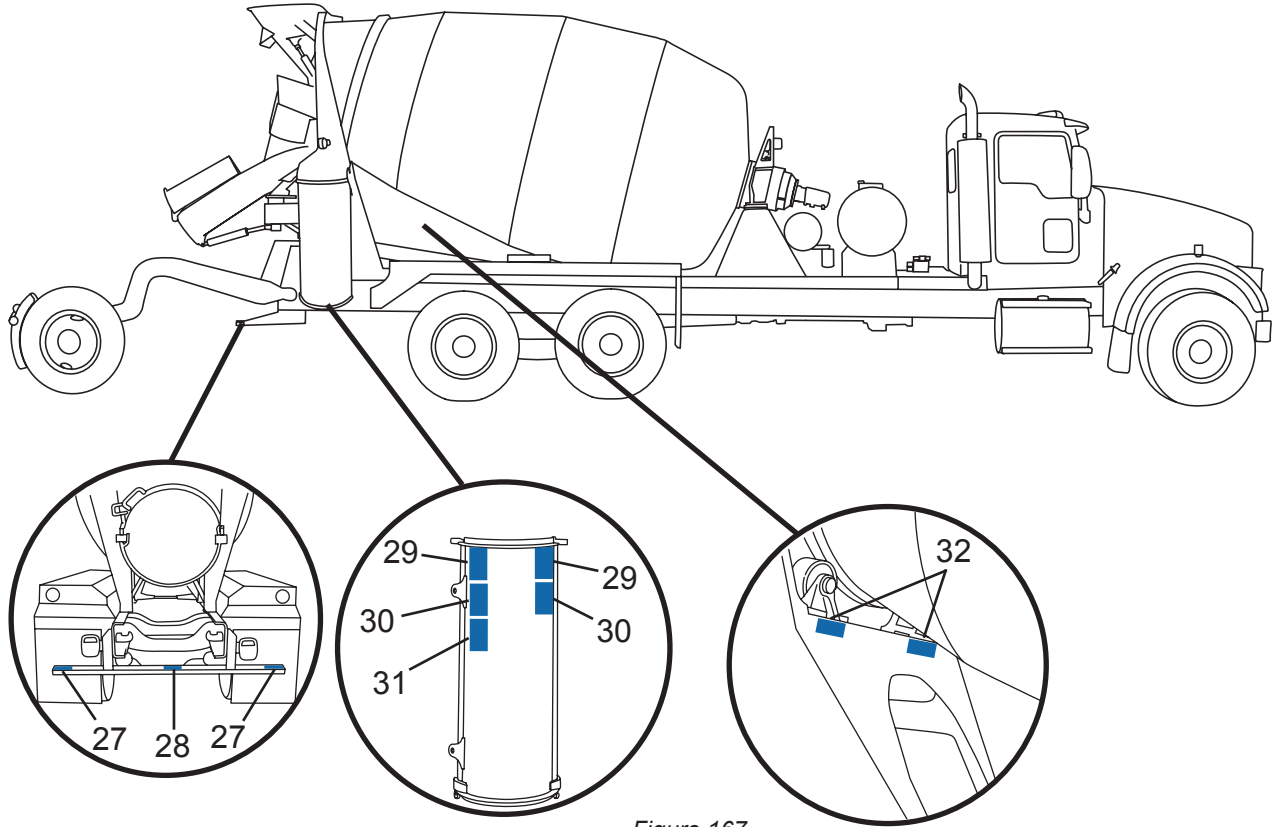

Figure 167

Preventive Maintenance

3.7.1.2 Driver Side Views

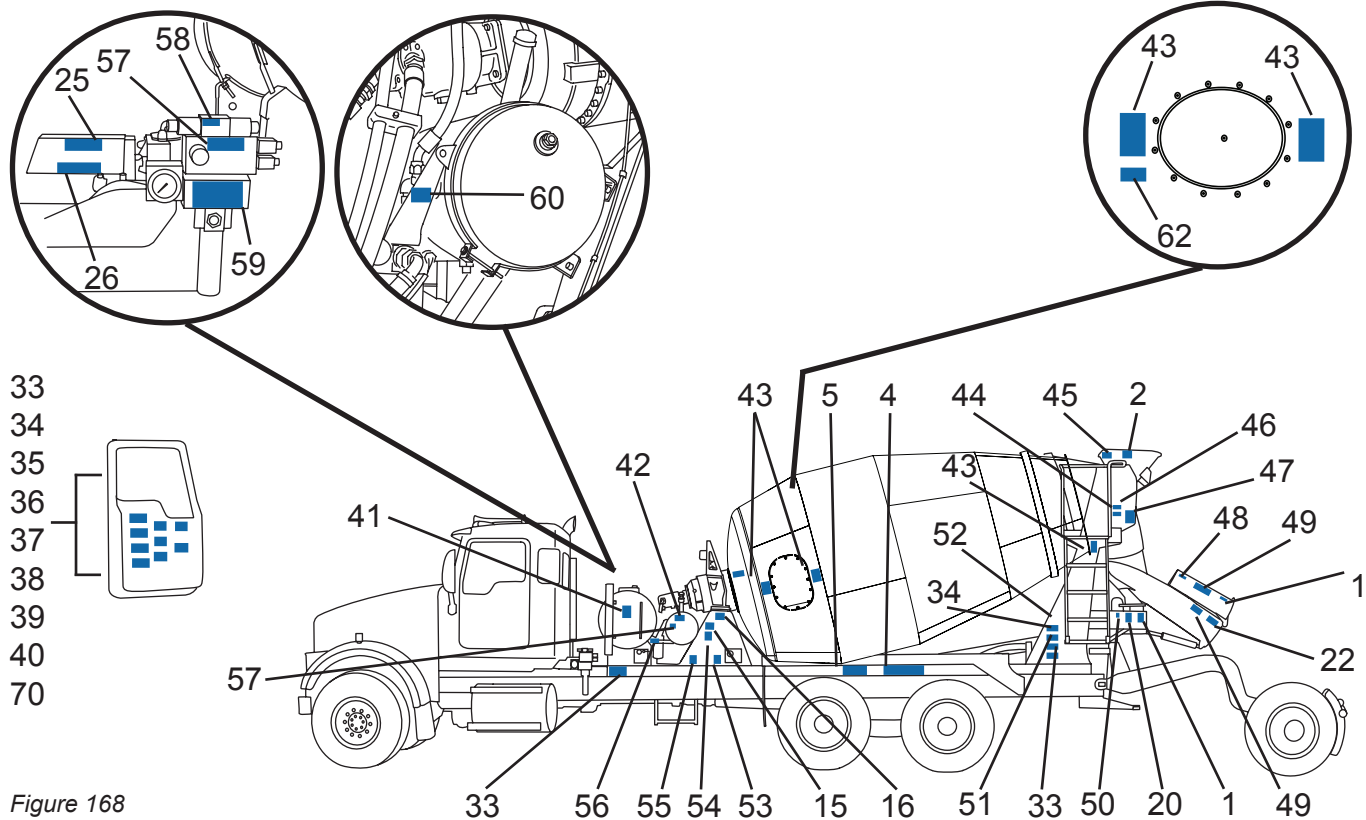

Figure 168

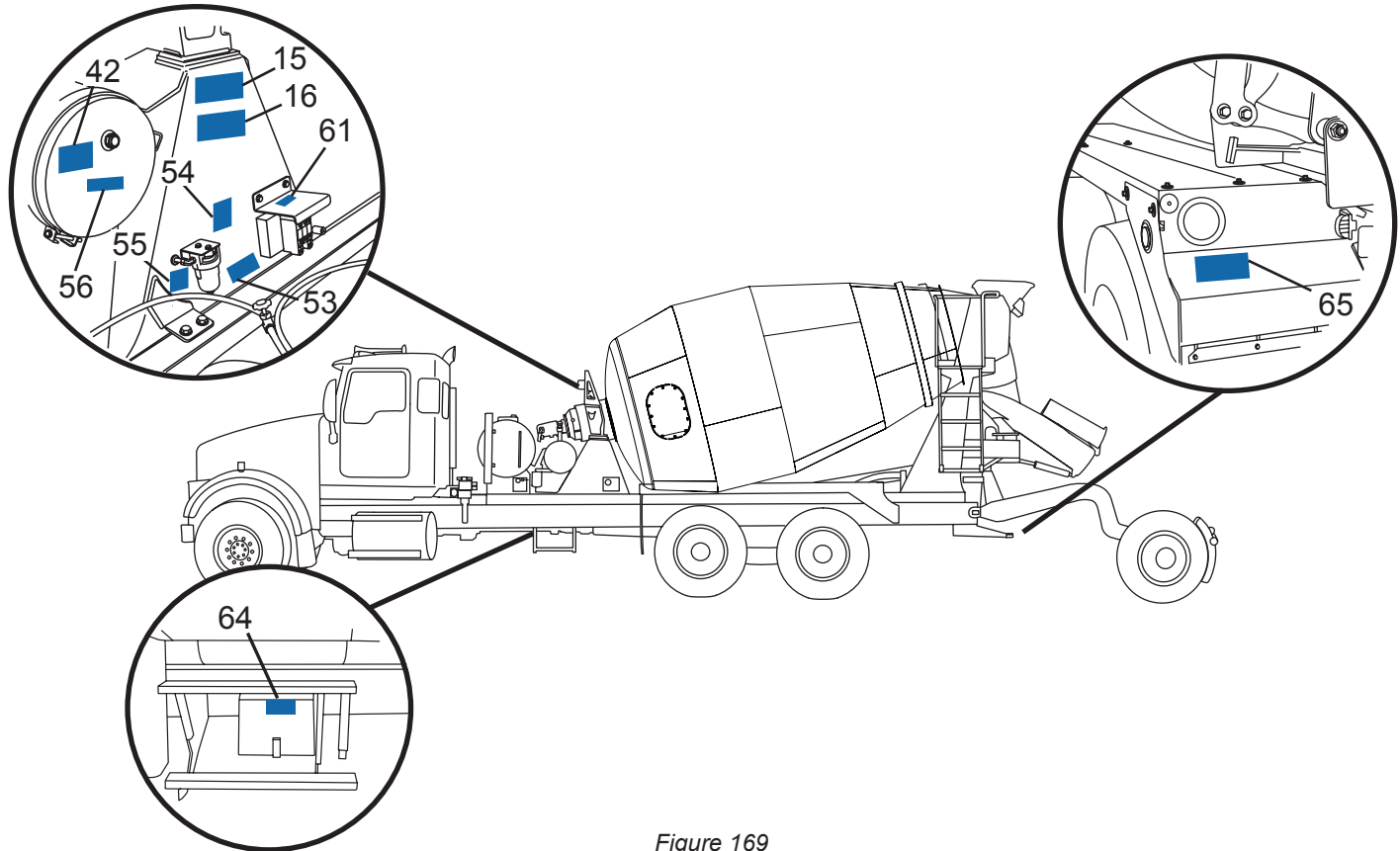

Figure 169

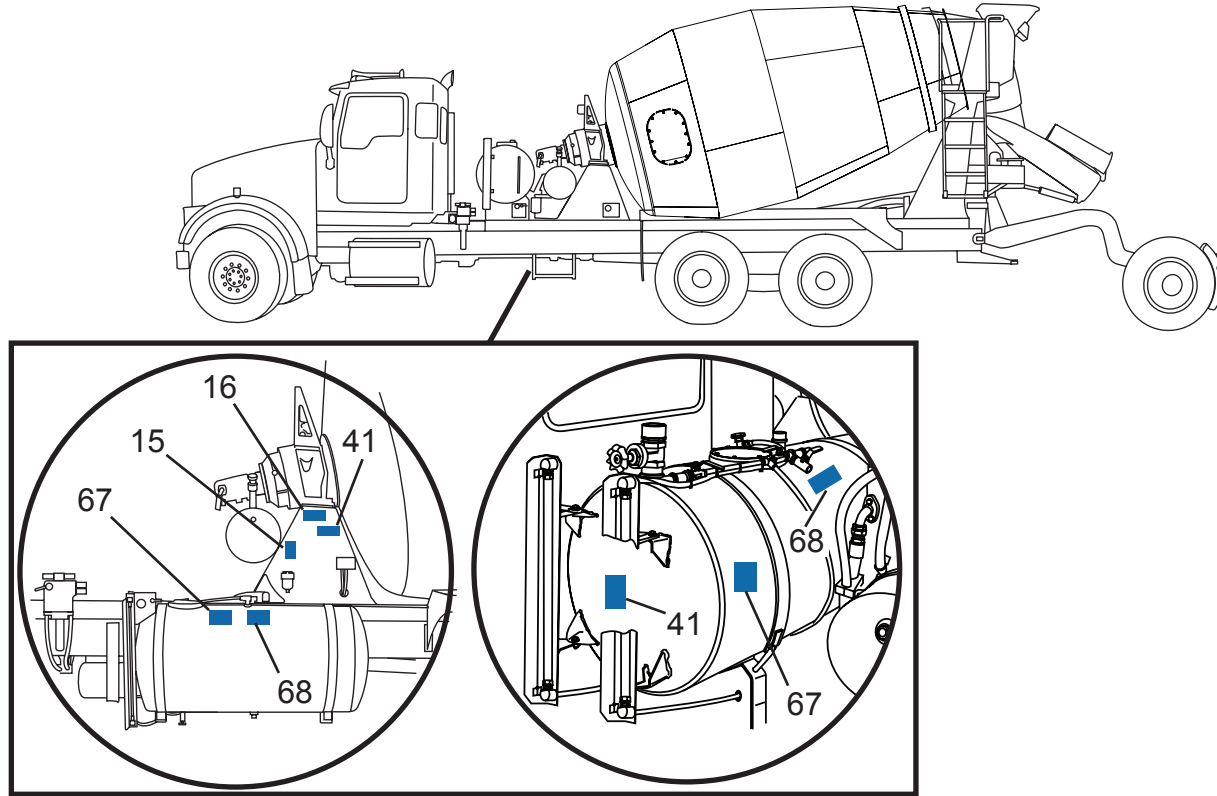

Figure 170

4.0 Optional Equipment Maintenance

4.1 Spray Bar Strainer

NOTE

Contaminants may vary, depending on the application.

The spray bar strainer (50 mesh) should be cleaned and inspected once a week.

1. Remove (unscrew) the cup (Figure 171, Item 3), and remove the cup and strainer (Figure 171, Item 4) from the strainer head (Figure 171, Item 1).
2. Clean the strainer (Figure 171, Item 4) with clear water. Inspect the strainer. Replace if torn or damaged.
3. Inspect the cup seal (Figure 171, Item 2). Replace if torn or damaged.
4. Install the strainer (Figure 171, Item 4) and cup (Figure 171, Item 3).

Preventive Maintenance

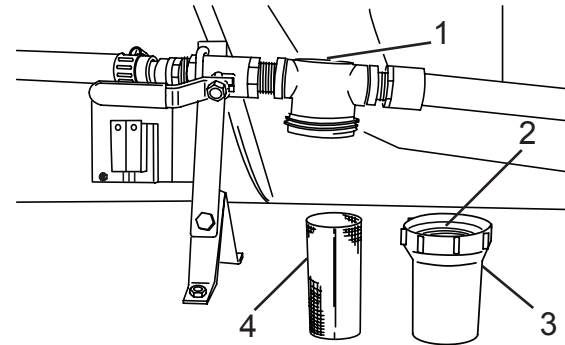

Figure 171

Preventive Maintenance

4.2 GPI® Water Meters

4.2.1 Battery Replacement

1. Remove four screws (Figure 172, Item 2) from the face of the meter and remove the faceplate (Figure 172, Item 1) from the meter body.

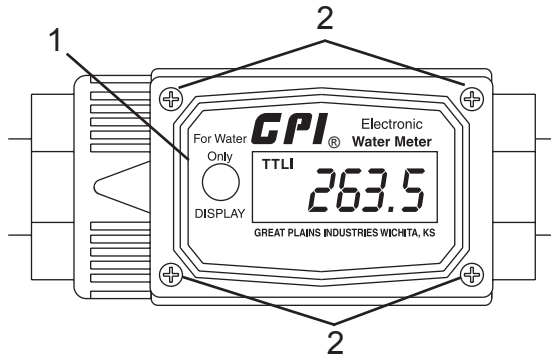

Figure 172

2. Remove the batteries, noting their orientation in the holder.
3. Inspect the terminals for corrosion. Clean as needed.
4. Install new batteries in the same orientation as noted during removal.

5. Inspect the O-ring to make sure it is fully seated in the housing.
6. Activate the display by briefly pressing the DISPLAY button (Figure 173, Item 4).
7. Check the display (Figure 173, Item 3) to verify that it is operating normally. Re-seat the batteries if needed.
8. Install the meter faceplate (Figure 173, Item 1) on the meter body with four screws (Figure 173, Item 2).

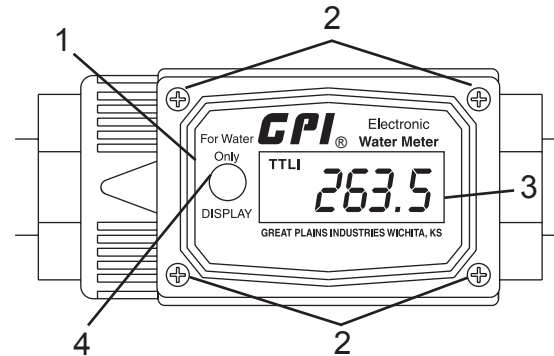

Figure 173

4.3 Optional Pusher Axle Maintenance

Refer to the vendor information supplied with the Mixer for maintenance and service information.

5.0 Lubrication

5.1 Daily Lubrication

Lubricate all the following points with a high-quality EP No. Lithium grease.

Daily lubrication intervals are based on a 10-hour day. If the Mixer is operated more hours per day or double shifted, the maintenance interval must be adjusted accordingly.

5.2 Daily Lubrication – Remote Lubrication System (If Equipped)

Mixers may be equipped with a remote lubrication system. This system positions grease fittings in easily accessible groups on the rear pedestal (Figure 174, Item 1), or in an alternate position on the discharge chute support pylon (Figure 175, Item 1). These fittings are connected to mixer components by tubes.

SAFETY NOTICE

Perform your company's Lockout/Tagout procedure. If your company does not have a Lockout/Tagout procedure, follow OSHA 1910.147 and 1910.146 Confined Space as appropriate.

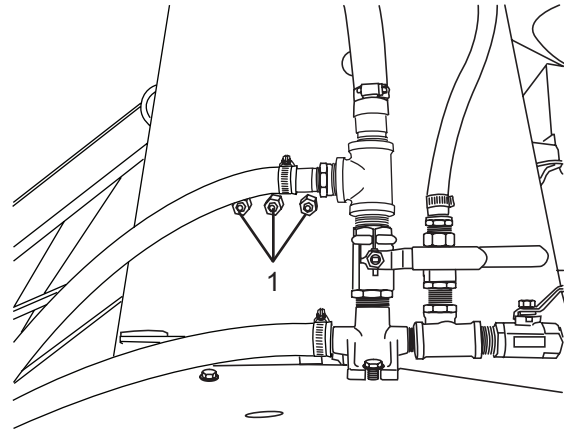

Figure 174

Standard Location

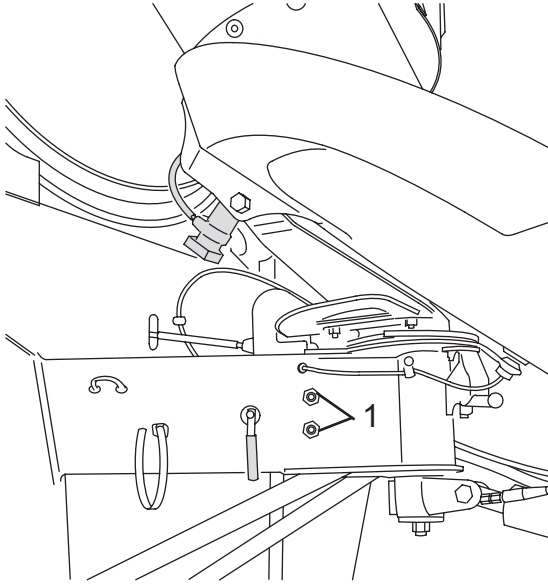

Figure 175

Alternate Location

5.3 Daily Lubrication – Central Lubrication Systems

Mixers may be equipped with one of several central lubrication systems. Refer to the vendor information supplied with the Mixer for operating and maintenance information.

SAFETY NOTICE

Perform your company's Lockout/Tagout procedure. If your company does not have a Lockout/Tagout procedure, follow OSHA 1910.147 and 1910.146 Confined Space as appropriate.

Lubrication Points		Lubricate Daily or Every 10 Hours	
Ref.	Description	No. of Fittings	Comments
A1	Drum Roller Bearings	2	Two Fittings – One Per Side
A2	Drum Roller Bearings – Remote Lubrication System	2	
A3	Drum Roller Bearings – Remote Lubrication System	2	Alternate Position
B	Drum Roller Track	—	Brush On

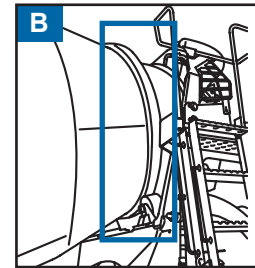
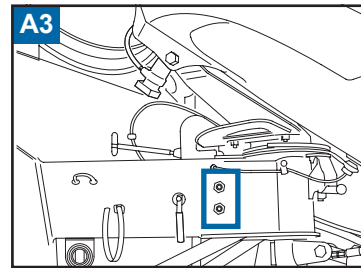
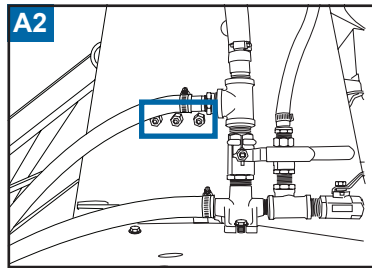
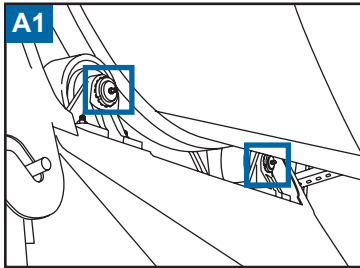
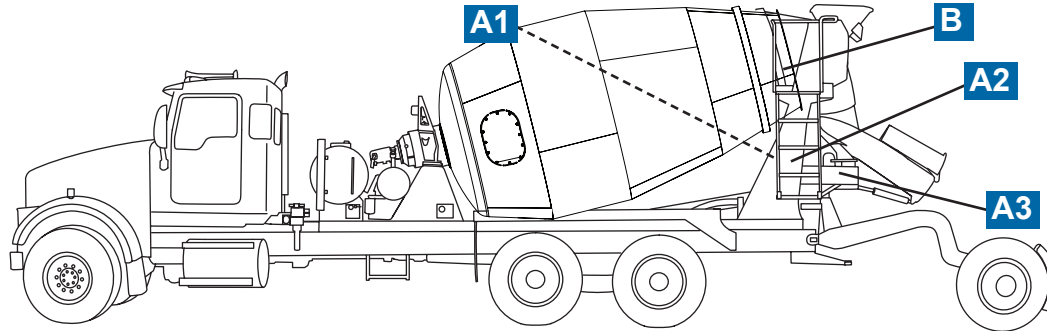

5.4 Weekly Lubrication

Lubricate all the following points with a high-quality EP No. 2 Lithium grease.

SAFETY NOTICE

Perform your company's Lockout/Tagout procedure. If your company does not have a Lockout/Tagout procedure, follow OSHA 1910.147 and 1910.146 Confined Space as appropriate.

Lubrication Points		Lubricate Weekly or Every 50 Hours	
Ref.	Description	No. of Fittings	Comments
C	PTO Shaft – Slip Joint	1	
C	PTO Shaft – U-Joint	2	Two Fittings – Front and Rear
D1	Main Chute Pivot	1	
D2	Main Chute Pivot – Remote Lubrication System	1	
E	Chute Manual Lock Shaft	—	Apply Grease to Shaft
F	Rear Drum Control Box (as required)	2	Two Fittings – One Per Side
G	Bridgemaster Axle Pivot Bushings	2	Two Fittings – One Per Side
H	Bridgemaster Axle Slack Adjuster	2	Two Fittings – One Per Side
J	Bridgemaster S-Cam Tube	2	Two Fittings – One Per Side
K	Bridgemaster Axle King Pins (Upper and Lower Fittings)	4	Four Fittings – Two Per Side
L	Bridgemaster Axle Tie Rod Ends	2	Two Fittings – One Per Side

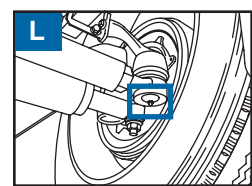
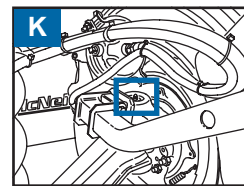
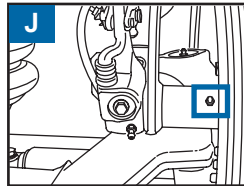
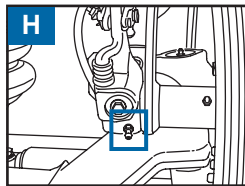
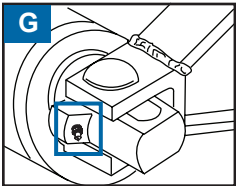
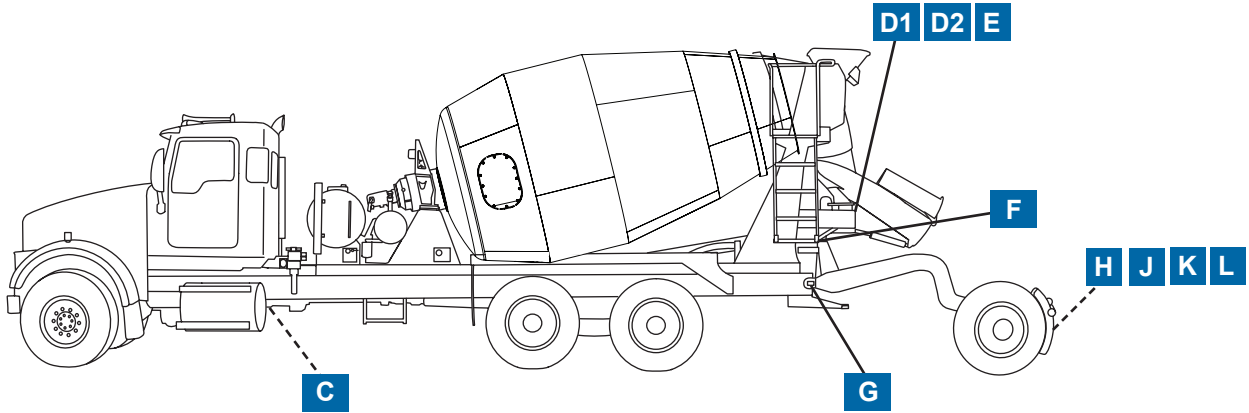
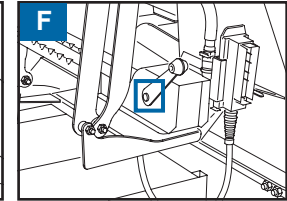
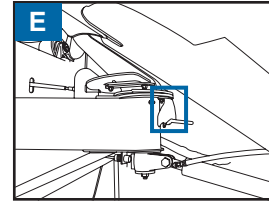
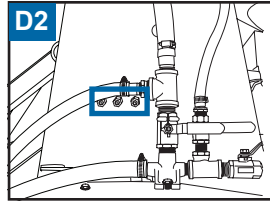
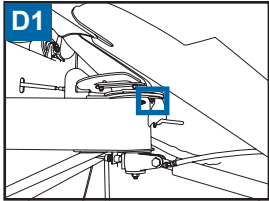
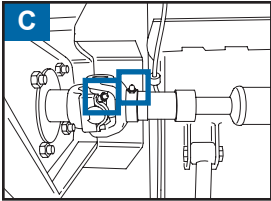

Index

A

Adjusting the Throttle Speed 133

B

Battery Cable Disconnect 10

Before Placing the Mixer Into Service 31

C

Chute Operation 138

 Position the Discharge Chute Assembly 140

 Unfold the Fold-Over Chute 138

 Using Chute Extensions 139

Complete Vehicle Document Decal 4

 Chassis build date 4

 Chassis manufacturer 4

 Gross Vehicle Weight 4

 Maximum rated weight per axle 4

 Tire and rim size and tire pressure specifications 4

 Vehicle (chassis) ID number 4

 Vehicle system build date 4

Control Functions for INSIGHT System 57

 Bridgmaster Axle Operation 71

 Bridgmaster Axle Service Brake Operation 73

 Normal Service Brake Operation 73

 Parking Service Brake Operation (Option) 73

 Chute Lock Function 67

Chute Raise/Lower and Swing Functions 68

Constant Speed Function (If Equipped - Electronic Drum

 Controls Only) 64

Drum Stop Operation 60

Emergency Manual Bridgmaster Axle Operation 73

Hopper, Chute Lock, and Chute Operation with Wireless

 Transmitter (If Equipped) 69

Hopper Function 66

Load Function (If Equipped - Electronic Drum Controls Only)

 62

Mix Function (If Equipped - Electronic Drum Controls Only)

 63

Rotating the Drum from the Joystick, Optional In-Cab Keypad,

 or Rear Pendant Keypad 58

Rotating the Drum with the Wireless Transmitter

 (If Equipped) 59

Start-Up Function 57

Work Lighting Functions 70

Control Functions for Traditional Controls 121

 Bridgmaster Axle Operation 121

 Bridgmaster Axle Service Brake Operation 127

 Normal Service Brake Operation (All Chassis Models)

 127

 Parking Service Brake Operation (Option) 127

D

Daily Lubrication 245

Daily Lubrication – Central Lubrication Systems 248

Daily Lubrication – Remote Lubrication System (If Equipped)

 245

Index

Discharging the Load..... 141

E

Emergency Manual Bridgmaster Axle Operation..... 73

End-of-Day Cleaning Procedure..... 146

Exterior Systems Arrangement..... 29

F

Fire Extinguisher..... 11

G

Gross Vehicle Weight 4

H

Hydraulic Foldover Chute 178

Hydraulic System

Hydraulic Oil Level..... 226

Hydraulic System and Components 227

L

Lubrication

Daily Lubrication 245

Daily Lubrication – Central Lubrication Systems 248

Daily Lubrication – Remote Lubrication System (If Equipped)

245

Weekly Lubrication 250

M

Maximum rated weight per axle..... 4

Revolution INSIGHT Mixer System Instruments

and Controls 33

Auxiliary Function Icons..... 37

Cab Control Keypad (Optional)..... 45

Cab Control Keypad (Standard) 43

Drum Revolution Counters Screen Overview 36

Home/Drum Screen Overview 34

Manual Drum Operation 55

Optional Joystick for Drum Pause, Chute Up/Down

Functions..... 46

Outside Controls 47

Cable Drum Control (If Equipped)..... 51

Manual Chute Lock 52

Rear Pendant Control Keypad 48

Speed/Direction Sensor Reading Screen Overview 35

Touch Screen Display Button Overview..... 41

Touch Screen Display Status Icons 42

Revolution Parts and Support..... 6

Revolution Traditional Cable Control System Instruments

and Controls..... 104

Add Water Function (If Equipped) 120

Cable Cab Controls 104

Cable Control Rocker Switch Functions..... 105

Cable Control Fuse Functions 109, 118

Cable Outside Controls..... 109

Cable Control Rear Control Pendant 110

Cable Rear Drum Control..... 113

Manual Chute Lock	115
Manual Drum Operation.....	116
Revolution Traditional Electronic Control System Instruments and Controls	
Add Water Function (If Equipped)	102
Drum Control Checkout Procedure.....	102
Electronic Cab Controls - Cab Control Box	88
Electronic Cab Control Rocker Switch Functions.....	89
Electronic Cab Controls - Cab Control Pendant	82
Electronic Cab Control Rocker Switch Functions.....	83
Electronic Control Fuse Functions.....	99
Electronic Outside Controls	94
Electronic Rear Pendant Controls.....	95
Manual Chute Lock	98
Fault Display - EP and RE Controls.....	101
Mixer Identification Plate	1
Mixer Serial Number Explanation	3

O

Operating Procedures	132
Optional Equipment	
Central Lubrication Systems.....	194
Chute Assist.....	180
Chute Blockers	183
Concrete Slump Meter.....	189
Setting the Digital Concrete Slump Meter for INSIGHT System Only	191
Setting the Mechanical Concrete Slump Meter.....	190
Discharge Chute Vibrator Valve.....	183

Flip-Up Charge Hopper.....	184
Foldover Stop	183
Hydraulic Chute Swing	182
Hydraulic Foldover Chute	178
Lateral Protection Device.....	185
Wireless Transmitter.....	196
Preco for INSIGHT System.....	187
Right Hand Turn Audible Warning System	185
Swing Away Throat (SAT) Charge Hopper	185
Optional Equipment Maintenance	
GPI Water Meters	244
Optional Pusher Axle Maintenance.....	245
Spray Bar Strainer	243

P

Positioning the Truck for Discharge.....	137
Preventive Maintenance Daily Checks	
Electrical System	227
Hydraulic System.....	226
Hydraulic Oil Level	226
Hydraulic System and Components.....	227
Mechanical System.....	228
Operation	234
Pneumatic System.....	228
Safety Signs.....	235
Standard (Steel) Drum.....	232
Preventive Maintenance Intervals	217
Proper Safety Equipment	13
Pusher Axle	214

Index

R

Rear Pendant Control Keypad.....	48
Reflective Warning Triangle Kit	11
Reporting Safety Defects.....	11
Returning from the Job Site.....	145

S

Safety Equipment	
Fire Extinguisher.....	11
Reflective Warning Triangle Kit.....	11
Safety Information	14
Safety Decals	
Safety Decal and Placard Locations.....	238
Split Water Tank (Optional).....	152

T

TMMB Certification Placard.....	1
Touch Screen Display Button Overview	41
Touch Screen Display Status Icons	42
Traveling to the Job Site.....	136
Triangle Kit	11

U

Upper Ladder Platform Gate Bar Usage (Optional Equipment)	
134	

W

Warm-Up Procedure.....	132
Wash Down the Mixer Before Leaving the Job Site	142
Water System Functions	168
Auto Washout System for INSIGHT System (Optional Equipment).....	170
Manual Washout System.....	172
Spray Bar.....	173
Wash-Out Hoses	168
Water Meter Function	174
Water System - Pressurized.....	153
Water System - Pump	160
Water Tanks.....	147
Weekly Lubrication	250
Working Around Concrete Pumps	135

This Page Intentionally Left Blank



(855) 202-6491