



REVOLUTION™

CONCRETE MIXERS

OPERATOR'S MANUAL

STANDARD MIXER

This manual includes information for:

- Revolution Mixer INSIGHT System™
- Revolution Traditional Controls

Part No. 1679123

Rev. 12/2023

© 2023 Revolution Concrete Mixers



Disclaimer:

This manual must not be used to repair your vehicle. Repair information is available by calling Revolution Customer Service at (855) 202-6491.

The information in this Operator's Manual will be your guide to operation and operator maintenance for this equipment.

All information, illustrations, and specifications in this manual are based on the information available at the time this manual was published. The illustrations used in this manual are intended as representative reference views only. Because of our continuous product improvement policy, we may modify information, illustrations, and/or specifications to explain and/or exemplify a product, service, or maintenance improvement. We reserve the right to make any change at any time without notice. Go to www.streetsmartparts.com for current information.

No part of this publication may be reproduced by any means - graphic, electronic, or mechanical, including photocopying, recording, taping, or information storage and retrieval systems for any use or purpose - without the written permission of Revolution Concrete Mixers.

For assistance in ordering OSHA Publications, contact:
U.S. Department of Labor/OSHA
200 Constitution Ave. NW
Room Number N3626
Washington, D.C. 20210
Telephone: 800-321-6742 • www.OSHA.gov

 **WARNING**

Operating, servicing, and maintaining this vehicle or equipment can expose you to chemicals including exhaust, carbon monoxide, phthalates, and lead, which are known to the state of California to cause cancer and birth defects or other reproductive harm. To minimize exposure, avoid breathing exhaust, do not idle the engine except as necessary, service your vehicle or equipment in a well ventilated area and wear gloves or wash hands frequently when servicing. For more information, go to www.p65warnings.ca.gov.

1.0 Identification

1.1 Mixer Identification Plate and TMMB Certification Placard

A Revolution Concrete Mixers identification plate (Figure 1, Item 1) is located on the left side of the front pedestal. The identification plate contains the serial number (Figure 1, Item 2) and the rated mix capacity (Figure 1, Item 3) of your mixer system.

The identification plate also contains the drum volume and water tank capacity.

Also located on the left side of the front pedestal is the Truck Mixer Manufacturers Bureau (TMMB) certification placard (Figure 1, Item 4). This decal indicates the certified maximum capacity of the Mixer.

The drum serial number (Figure 1, Item 5) is stamped into the pedestal.

Please fill out the following information and have it ready when calling Revolution Concrete Mixers for parts or product information:

Date of Purchase: _____

Branch: _____

Serial Number of Mixer: _____

Serial Number of Drum: _____

VIN* _____

*Refer to chassis manufacturer literature for location.

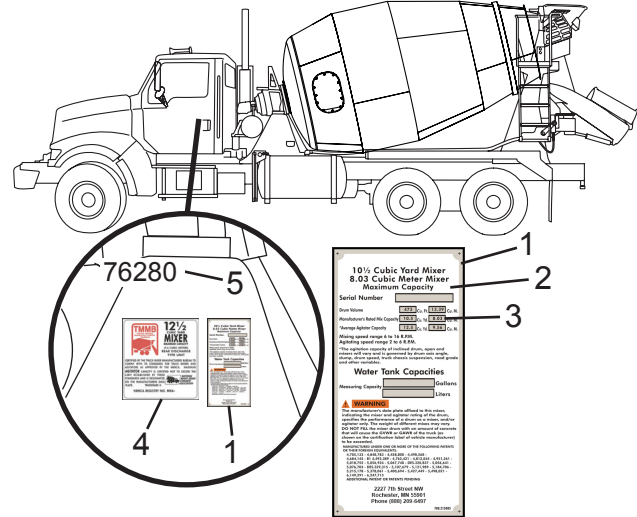

Figure 1

Foreword

1.1.1 Mixer Serial Number Explanation

The Mixer Serial Number (Figure 2, Item 2) located on the identification plate (Figure 2, Item 1) will be needed when making service inquiries or when ordering parts.

The serial number is a five-digit sequential number, and contains no information such as Mixer build date, etc. This type of information is located on the Complete Vehicle Document Decal.

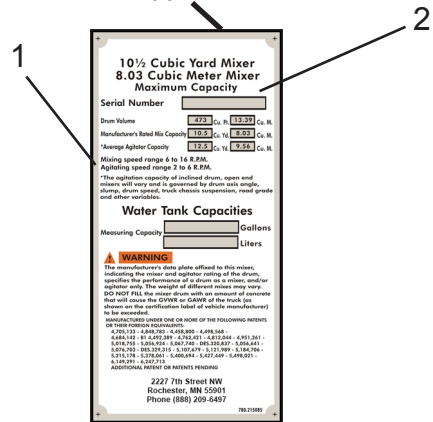
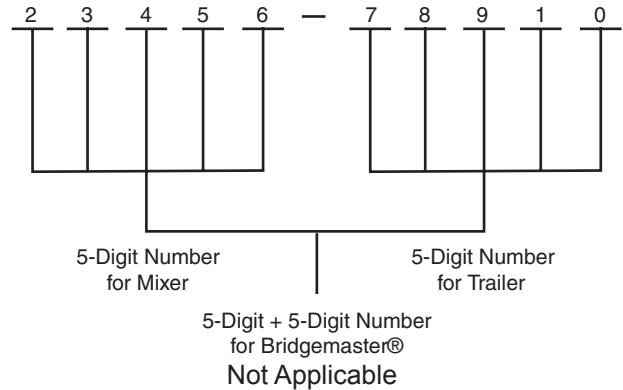

Figure 2

1.2 Complete Vehicle Document Decal

The Complete Vehicle Document decal (Figure 3, Item 1) documents the axle load and tire ratings as the vehicle left the Revolution production line. This decal is located inside the cab and may be placed on the driver's door, doorjamb, or the seat riser.

This decal includes information such as the maximum rated weight per axle (Item 2), Gross Vehicle Weight (GVW) (Item 3), chassis manufacturer (Item 4), chassis build date (Item 5), vehicle (chassis) ID number (Item 6), tire and rim size and tire pressure specifications (Item 7), and the mixer vehicle system build date (Item 8).

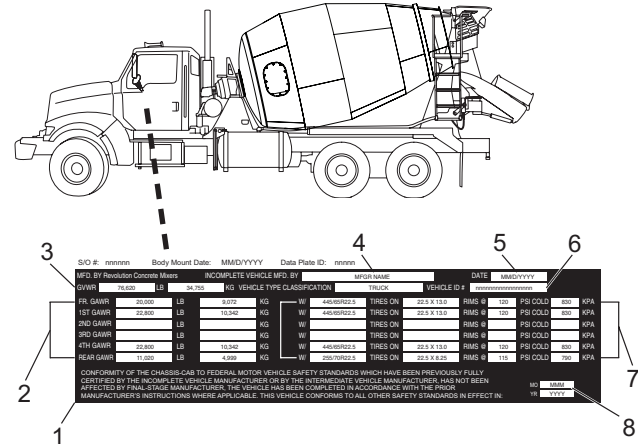

Figure 3

2.0 Purpose of Manual

This Operator's Manual provides operation and operator maintenance instructions for the Standard Mixer manufactured by Revolution Concrete Mixers

The information in this operator manual will be your guide to operation and operator maintenance for this equipment.

Keep this manual with the vehicle at all times.

WARNING

The operator of this Mixer must be properly licensed and trained to operate this Mixer. If you are uncertain how to operate this Mixer, inform your supervisor or contact Revolution Customer Service at (855) 202-6491. Failure to comply may result in serious personal injury or death and void the mixer vehicle warranty.

NOTE

This manual is limited to the operation and light maintenance of the Mixer system only. Because the Mixer system may be mounted on various chassis, this manual does not include the operation or maintenance of the chassis. Refer to the chassis manual provided with your Mixer for chassis operation and maintenance information.

3.0 Scope

This manual provides information for use by the equipment operator under the following headings:

1. **Safety.** Includes important safety information.
2. **Operation.** Includes equipment identification. Includes control functionality and normal equipment operation.
3. **Preventive Maintenance.** Includes basic preventive maintenance information for the operator.

4.0 Parts and Service

Contact your Revolution Parts and Support to order parts, receive service information, or for other assistance.

To order a replacement manual or safety decals, contact Revolution at the following phone number or website.

Contact by phone or visit www.streetsmartparts.com.

We have factory owned parts and service centers near you.

Phone Number (855) 202-6491

5.0 Corporate Headquarters

Contact Revolution Concrete Mixers directly at our corporate headquarters at the following address, phone number, and website.

Revolution Concrete Mixers
2227 7th Street NW
Rochester, MN 55901

Telephone: 888-209-6497

Corporate Website: www.revolutionmixers.com

This Page Intentionally Left Blank

SAFETY

1.0	IMPORTANT SAFETY INFORMATION	1
1.1	Applying the Lockout/Tagout Procedure	1
1.1.1	Removing the Lockout/Tagout Procedure	6
1.1.2	Restoring Equipment to Normal Production Operations	9
1.2	Battery Cable Disconnect	9
1.3	Safety Equipment	10
1.4	Reporting Safety Defects	10
2.0	PRODUCT SAFETY INFORMATION	11
2.1	Use Proper Safety Equipment	12
3.0	SAFETY INFORMATION	13
3.1	Safety	13
3.2	Cab Operation	15
3.3	Outside Operation	17
3.4	Maintenance	21
3.5	Hydraulics	23
3.6	Electrical	27
3.7	Chute Extensions	28
4.0	SAFETY SIGNS	29
4.1	Safety Sign and Placard Locations	31

Table of Contents

4.1.1	Curb Side Views.....	31
4.1.2	Street Side Views.....	33

GENERAL INFORMATION

1.0	EXTERIOR SYSTEMS ARRANGEMENT.....	35
1.1	Curb Side View.....	35
1.2	Street Side View.....	36

OPERATION

1.0	BEFORE PLACING THE MIXER INTO SERVICE.....	37
1.1	INSIGHT System Deactivate Transport Feature.....	37
1.2	Traditional Controls Deactivate Transport Feature.....	38
2.0	INSIGHT MIXER SYSTEM INSTRUMENTS AND CONTROLS.....	39
2.1	Home/Drum Screen Overview.....	40
2.2	Speed/Direction Sensor Reading Screen Overview.....	41
2.3	Drum Revolution Counter Screen Overview.....	42
2.4	Auxiliary Function Icons.....	43
2.4.1	INSIGHT System Enabled Package.....	44
2.5	Touch Screen Display Button Overview.....	47
2.6	Touch Screen Display Status Icons.....	48
2.7	Cab Control Keypad (Standard).....	49
2.8	Cab Control Keypad (Optional).....	51

2.9	Optional Joystick for Drum Pause, Chute Up/Down Functions	53
2.10	Outside Controls.....	54
2.10.1	Rear Pendant Control Keypad	55
2.10.2	Cable Drum Control (If Equipped).....	57
2.10.3	Manual Chute Lock	58
2.11	Fuse Functions	59
2.12	Manual Drum Operation	61
2.12.1	Manual Override - CHARGE and DISCHARGE	61
3.0	CONTROL FUNCTIONS FOR INSIGHT SYSTEM	62
3.1	Start-Up Function	62
3.2	Rotating the Drum from the Joystick, Optional In-Cab Keypad, or Rear Pendant Keypad	63
3.3	Rotating the Drum with the Wireless Transmitter (If Equipped)	64
3.4	Drum Stop Operation	65
3.5	Load Function (If Equipped - Electronic Drum Controls Only)	67
3.6	Mix Function (If Equipped - Electronic Drum Controls Only).....	68
3.7	Constant Speed Function (Electronic Drum Controls Only).....	69
3.8	Hopper Function.....	71
3.9	Chute Lock Function	72
3.10	Chute Raise/Lower and Swing Functions	73
3.11	Hopper, Chute Lock, and Chute Operation with Wireless Transmitter (If Equipped).....	74

Table of Contents

3.12	Work Lighting Functions	75
4.0	TRADITIONAL ELECTRONIC CONTROL SYSTEM INSTRUMENTS AND CONTROLS	76
4.1	EP Drum Control System	76
4.1.1	Maestro Revision E-10	76
4.1.2	How to Identify Revision E-10	76
4.2	Electronic Cab Controls - Cab Control Pendant	78
4.2.1	Electronic Cab Control Rocker Switch Functions	79
4.2.2	Indicator Light and Display Functions	82
4.3	Electronic Cab Controls - Cab Control Box	83
4.3.1	Electronic Cab Control Rocker Switch Functions	84
4.3.2	Indicator Light and Display Functions	86
4.4	Electronic Outside Controls	87
4.4.1	Electronic Rear Pendant Controls	88
	• 4.4.1.1 By-Passing the Rear Pendant	89
4.4.2	Manual Chute Lock	90
4.5	Fuse Functions	91
5.0	TRADITIONAL CABLE CONTROL SYSTEM INSTRUMENTS AND CONTROLS	93
5.1	Cable Cab Controls	93
5.1.1	Cable Cab Control Rocker Switch Functions	94
5.1.2	Indicator Light and Display Functions	96

5.2	Cable Outside Controls	97
5.2.1	Cable Rear Pendant Controls	98
• 5.2.1.1	By-Passing the Rear Pendant	100
5.2.2	Cable Drum Control.....	101
5.2.3	Manual Chute Lock	103
5.3	Fuse Functions.....	104
5.4	Manual Drum Operation	106
5.4.1	Manual Override - CHARGE and DISCHARGE	106
5.4.2	Manual Override - Locking for Transit	107
5.5	Add Water Function (If Equipped)	109
5.5.1	Manual Water Injection System.....	109
5.5.2	Remote Water Injection System for Traditional Control System	110
6.0	OPERATING PROCEDURES	110
6.1	Start-Up Procedure	110
6.2	Warm-Up Procedure.....	111
6.3	Adjusting the Throttle Speed	111
6.3.1	Paccar, Navistar, and Detroit Diesel Engines.....	112
6.3.2	Mack® Engines – Rear Pendant	112
6.3.3	Mack® Engines – Wireless Remote Control.....	112
6.3.4	Cummins® Engines	113

Table of Contents



6.4	Upper Ladder Platform Gate Bar Usage (Optional Equipment)	113
6.5	Loading the Mixer Drum	113
6.5.1	Working Around Concrete Pumps	114
6.6	Traveling to the Job Site	115
6.7	Positioning the Truck for Discharge	115
6.8	Chute Operation	116
6.8.1	Unfolding the Fold-Over Chute	116
6.8.2	Using Chute Extensions	118
6.8.3	Positioning the Discharge Chute Assembly	119
6.9	Discharging the Load	120
6.10	Wash Down the Mixer Before Leaving the Job Site	121
6.11	Returning from the Job Site	124
6.12	End-of-Day Cleaning Procedure	125
6.12.1	Standard (Steel) Drum	125
6.12.2	End-of-Day Checks	125
7.0	WATER TANKS	126
7.1	Water Tank Safety	126
7.2	Water Tank Operation	127
7.2.1	Introduction	127
7.2.2	Daily Operation	127

• 7.2.2.1 Tank Integrity	127
• 7.2.2.2 Pressure Regulator Valve	128
• 7.2.2.3 Pressure Relief Valve	128
7.2.3 Daily Operation.....	128
7.2.4 Vehicle Handling Characteristics.....	129
7.3 Water Tank Safety Sign Identification.....	129
7.4 Water Tank Mounting Positions	130
7.5 Standard Water Tank.....	130
7.5.1 Single Sight Gauge	130
7.6 Split Water Tank (Optional).....	131
7.6.1 Dual Sight Gauges	131
8.0 WATER SYSTEM - PRESSURIZED	132
8.1 Depressurizing the Water Tank	132
8.2 Pressurizing the Water Tank.....	133
8.3 Draining the Water System.....	134
8.4 Filling the Main Tank.....	137
8.5 Filling the Chemical Tank (Split Tank Option).....	138
9.0 WATER SYSTEM - PUMP.....	139
9.1 Pump Operation	139
9.2 Filling the Water Tank	142

Table of Contents



9.3	Filling the Chemical Tank - Steel or Aluminum Tanks (Split Tank Option)	143
9.4	Draining the Water System	144
10.0	WATER SYSTEM FUNCTIONS	148
10.1	Wash-Out Hoses (Optional Equipment)	148
10.1.1	Upper Wash-Out Hose	148
10.1.2	Front Wash-Out Hose	148
10.1.3	Valve Drain	149
10.2	Auto Washout System for INSIGHT System (Optional Equipment)	150
10.3	Manual Washout System	152
10.4	Spray Bar (Optional)	152
10.5	Water Meter Function (Optional)	153
10.5.1	Precision Water Meters	153
10.5.2	BR Industries (BM-25) Water Meter	155
10.5.3	GPI® Water Meters	156
10.5.4	UFM Water Meters	157
10.5.5	Operation	157
11.0	OPTIONAL EQUIPMENT	158
11.1	Hydraulic Fold-Over Chute	158
11.2	Chute Assist	160
11.3	Hydraulic Chute Swing	162

11.4 Discharge Chute Vibrator Valve.....	163
11.5 Chute Blockers	164
11.6 Foldover Stop	165
11.7 Flip-Up Charge Hopper	166
11.8 Swing Away Throat (SAT) Charge Hopper	167
11.9 Right Hand Turn Audible Warning System	168
11.10 Lateral Protection Device	168
11.11 Preco for INSIGHT System.....	170
11.12 Concrete Slump Meter.....	172
11.12.1 Setting the Mechanical Concrete Slump Meter	172
11.12.2 Setting the Digital Concrete Slump Meter for INSIGHT System Only	174
• 11.12.2.1 Loading a Slump Calibration Profile.....	176
11.13 Central Lubrication Systems.....	178
11.14 Wireless Remote Control (Optional).....	180
11.14.1 Wireless Remote Control (Cab Console Version)	180
• 11.14.1.1 Control Buttons and Switches For INSIGHT System.....	180
• 11.14.1.2 LED Indicators	183
• 11.14.1.3 Control Buttons and Switches For Traditional Controls	184
• 11.14.1.4 LED Indicators	187
11.14.2 Cleaning the Transmitter	188

Table of Contents



11.14.3	Wireless Remote Control Troubleshooting	188
•	11.14.3.1 Diagnostic Codes – Transmitter	188
11.14.4	Receiver Locations	192
•	11.14.4.1 LED Indicators	192
•	11.14.4.2 Normal Operation	193
•	11.14.4.3 Fault Codes	194
12.0	CHASSIS OPTIONS	197
12.1	Pusher and Tag Axles	197
12.1.1	Raising or Lowering Pusher Axle for INSIGHT System Only	198
12.1.2	Raising or Lowering Tag Axle for INSIGHT System Only	199
12.1.3	Lowering Pusher or Tag Axle for Traditional Controls Only	200
12.1.4	Raising Pusher or Tag Axle for Traditional Controls Only	200

PREVENTIVE MAINTENANCE

1.0	PREVENTIVE MAINTENANCE	201
1.1	DOT Pre-Trip	201
2.0	PREVENTIVE MAINTENANCE INTERVALS	201
3.0	PREVENTIVE MAINTENANCE DAILY CHECKS	208
3.1	Safety Signs	208
3.2	Hydraulic System	208
3.2.1	Hydraulic Oil Level	208

3.2.2	Hydraulic System and Components	209
3.3	Electrical System	209
3.3.1	Lighting System	209
3.3.2	Warning Alarm System	210
3.4	Pneumatic System	210
3.4.1	Pneumatic Lines and Fittings	210
3.4.2	Coalescing Filter	210
3.5	Mechanical System	211
3.5.1	Mixer Components and Pedestals	211
3.5.2	Water Tanks	212
3.5.3	Chute Extensions	213
3.5.4	Chute Assist	213
3.6	Standard (Steel) Drum	215
3.6.1	Standard (Steel) Drum Inspection	215
3.6.2	Concrete Removal	217
3.7	Operation	218
3.7.1	Mixer Controls	218
4.0	OPTIONAL EQUIPMENT MAINTENANCE	219
4.1	Spray Bar Strainer	219
4.2	GPI® Water Meters	220

Table of Contents



4.2.1	Battery Replacement.....	220
4.3	Optional Pusher Axle Maintenance	221
5.0	LUBRICATION.....	221
5.1	Daily Lubrication	221
5.2	Daily Lubrication – Remote Lubrication System (If Equipped)	221
5.3	Daily Lubrication – Central Lubrication Systems.....	224
5.4	Weekly Lubrication	226
5.5	Semi-Annual Lubrication	228

TROUBLESHOOTING

1.0	INTRODUCTION.....	229
2.0	TROUBLESHOOTING CHART	230
2.1	Control System.....	230
2.2	Electrical System.....	231
2.3	Water System – Pressurized	234
2.4	Water System – Pump.....	234
2.5	Pneumatic System	235
2.6	GPI® Water Meter	235
2.7	BR Industries Water Meter (Optional)	236
2.8	UFM Water Meter	236

INDEX

INDEX.....	237
------------	-----

This Page Intentionally Left Blank

1.0 Important Safety Information

WARNING

READ AND UNDERSTAND THIS ENTIRE MANUAL BEFORE OPERATING, REPAIRING, OR ADJUSTING YOUR REVOLUTION EQUIPMENT.

THOSE WHO USE AND MAINTAIN THIS EQUIPMENT MUST BE THOROUGHLY TRAINED AND FAMILIAR WITH THE PRODUCT.

IF INCORRECTLY USED OR MAINTAINED, THIS EQUIPMENT CAN CAUSE SEVERE INJURY.

Always keep this manual in a location where it is readily available for persons who operate or maintain the product. Additional copies of this manual are available from Revolution Concrete Mixers. Please contact Revolution Concrete Mixers if you require additional manuals or if you have any questions about the information in this manual, this product, or safe operating procedures.

THESE SAFETY PROCEDURES ARE FOR YOUR OWN PROTECTION.

Do not operate this equipment until you have read its contents thoroughly. Read and understand the NRMCA manual that is placed in the vehicle's cab. Please contact Revolution Concrete Mixers if you require assistance.

Should operators of this equipment have a reading or learning disability, dyslexia, or other such condition, they must be assigned a mentor/trainer to read and explain to them the entire contents of this manual as well as the safety guidelines, danger, caution, and warning signs on this unit. Such individuals should not be allowed to operate this equipment until they thoroughly understand all of these materials. Failure to do so can result in serious injury or death.

Safety and safe working procedures must be followed at all times.

Perform your company's Lockout/Tagout procedure. If your company does not have a Lockout/Tagout procedure, follow OSHA 1910.147 and 1910.146 Confined Space as appropriate.

1.1 Applying the Lockout/Tagout Procedure

1. Before any personnel can perform mixer drum service or maintenance, the employee or supervisor must inform the driver that his/her vehicle/mixer system is going to be "Locked Out," and that he/she must not attempt to restart it until notified that it is safe to do so.
2. Position the truck on a firm, level surface. Place the

Safety

transmission in PARK or NEUTRAL, and engage the park brake. Allow the engine to run at idle. (Refer to the Operator's Manual supplied by the chassis supplier for all parking procedures.)

3. Place wheel chocks or blocks in front of and behind the truck's front wheels.
4. Position the drum hatch (Figure 1, Item 1) so the hatch is on the driver's side to perform service and maintenance.
 - Control the drum speed by manipulating the drum control on the cab keypad or the lever in the cab, or the control lever at the rear of the truck.
5. Make sure that the mixer drum warning signs (Figure 1, Item 2) are clean, readable, and properly positioned. Replace any damaged or unreadable signs immediately.

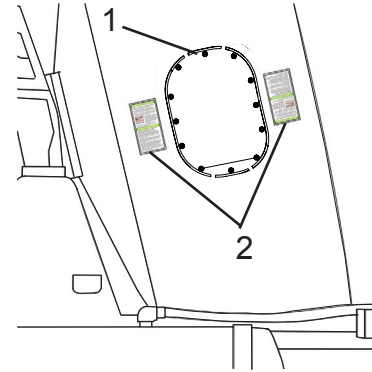

Figure 1

NOTE

Shutting off the truck engine will stop mixer drum rotation.

6. Engage the park brake and stop the chassis engine. (Refer to the Operator Manual supplied by the chassis supplier for all shut-down procedures.)
7. Before entering the mixer drum or performing service, the service/maintenance person must:
 - a. Shut off the truck engine.
 - b. Carry all ignition keys in his/her pocket.

- c. Tag steering wheel using a nonreusable fastener.
- 8. Roll up all cab windows and lock all doors.
- 9. Place magnetic “DANGER” signs (Figure 2, Item 1) on both doors: “Man working on drum. Do not start Mixer or rotate drum. Serious personal injury or death can occur.”

NOTE: If the Mixer is equipped with INSIGHT System, proceed to Step 14. For Mixers with Traditional Controls, continue with the following steps.

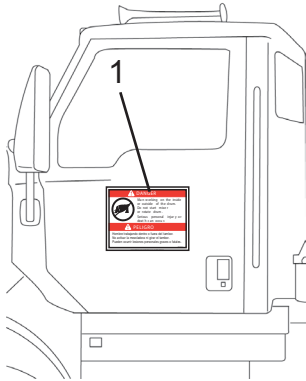

Figure 2

NOTE

Step 10 applies to trucks with RE (Remote Electric) controls. If equipped with EP (Electric Proportional) controls, proceed to Step 11.

- 10. **For Traditional Controls with RE (Remote Electric Controls) Only:** Locate and disconnect the main electrical connector (Figure 3, Item 1) from the charge/discharge coils. Move the connector away from its mating connector. Proceed to Step 14.

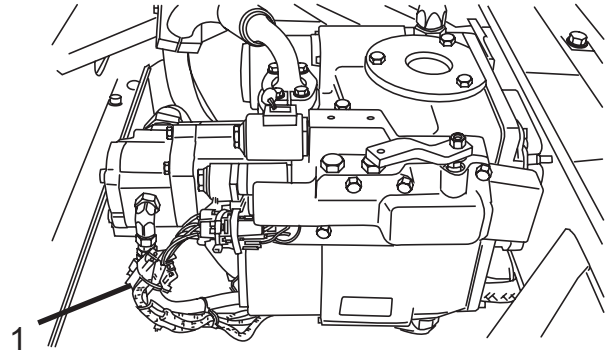

Figure 3

RE (Remote Electric) Controls

Safety

11. **For Traditional Controls with EP (Electric Proportional Controls) Only:** Locate and disconnect the main electrical connector (Figure 4, Item 1) from the charge/discharge coils. Move the connector away from its mating connector.
12. Locate and remove the charge/discharge manual override buttons (Figure 4, Items 2 and 3).

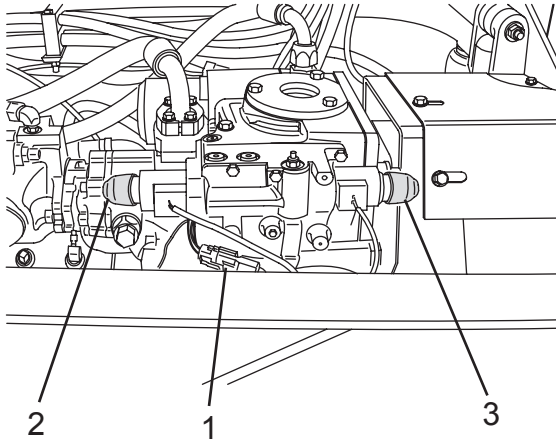

Figure 4

EP (Electric Proportional) Controls

13. Remove the pins (Figure 5, Item 1) from the override caps (Figure 5, Item 2), and replace the caps. Place the pins in your pocket with the truck keys.

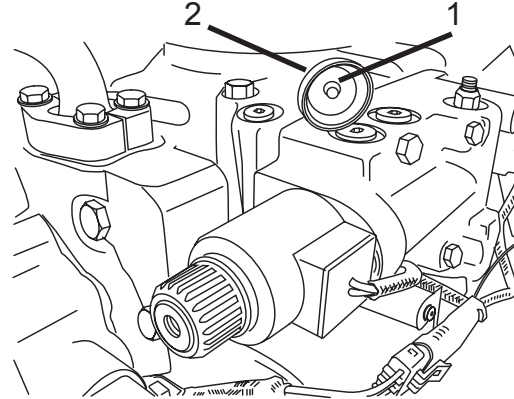

Figure 5

EP (Electric Proportional) Controls

⚠ WARNING

If performing service in or on the drum, the dual turnbuckle wedge assembly (and additional blocking as needed) must be used to prevent drum movement. Failure to comply may result in serious personal injury or death.

⚠ CAUTION

Concrete build-up and removal of that concrete with pounding or the use of hydraulic tools might cause the drum to slip over the turnbuckle wedge. To help prevent this, additional blocking of the drum may be required. Failure to comply may cause damage to property or equipment.

14. Place the dual turnbuckle wedge assembly base (Figure 6, Item 1) on the rear pedestal. Make sure the wedge assembly base has a flat, clean surface. Extend the turnbuckles (Figure 6, Item 2) so the wedges are firmly in place between the drum roller track and rollers. Evenly snug up the turnbuckles one turn or more as needed to prevent possible drum rotation.
15. Tighten the turnbuckle jam nuts (Figure 6, Item 3) to secure the wedges in place.
16. Place operating equipment at its lowest potential energy position to prevent free fall.
17. Install blocking devices to prevent any raised device from falling.
18. If maintenance is needed on the hydraulic or pneumatic systems, after blocking devices are installed, relieve stored hydraulic or pneumatic pressure.

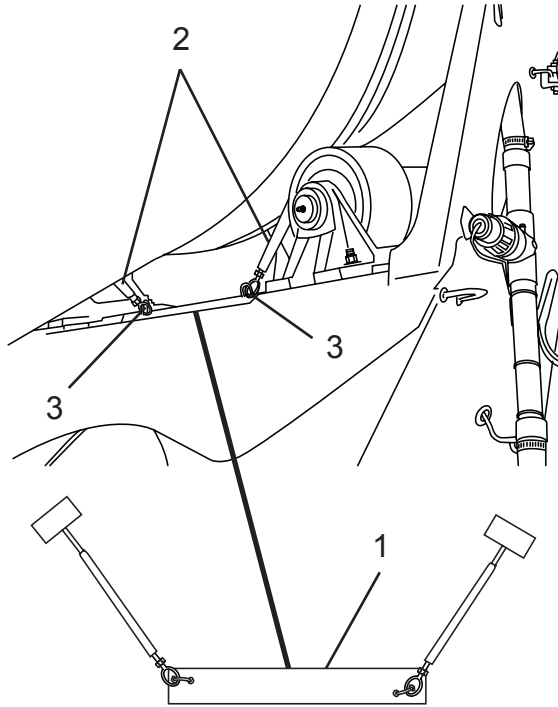

Figure 6

1.1.1 Removing the Lockout/Tagout Procedure

1. Loosen the turnbuckle jam nuts (Figure 7, Item 1).
2. Rotate the turnbuckles (Figure 7, Item 2) to retract the wedges from the drum roller track and rollers.
3. Remove the dual turnbuckle wedge assembly (Figure 7, Item 3) and any blocking from the rear pedestal.

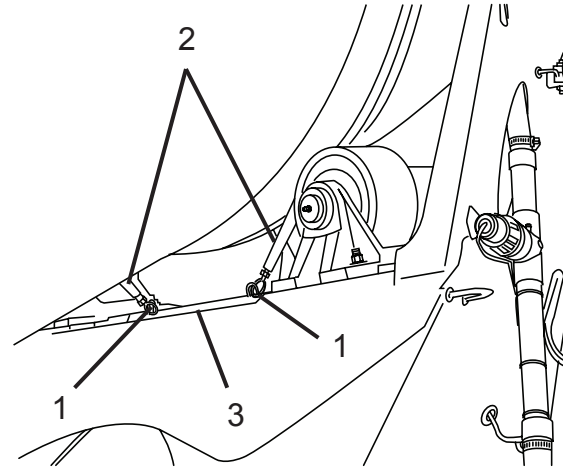

Figure 7

4. **For Traditional Controls with RE (Remote Electric Controls) Only:** Connect the main electrical connector (Figure 8, Item 1) to the charge/discharge coils. Proceed to Step 8.

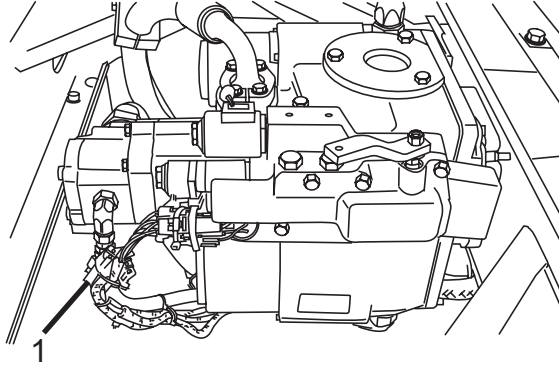

Figure 8

RE (Remote Electric) Controls

5. **For Traditional Controls with EP (Electric Proportional Controls) Only:** Install the pins (Figure 9, Item 1) in the override caps (Figure 9, Item 2).

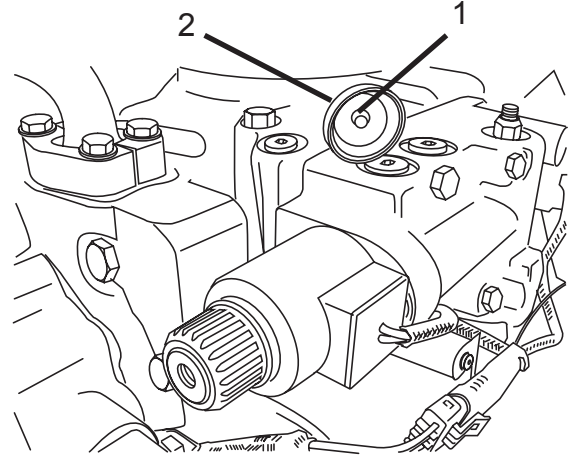

Figure 9

EP (Electric Proportional) Controls

Safety

6. Connect the main electrical connector (Figure 10, Item 1) to the charge/discharge coils.
7. Install the charge/discharge manual override caps (Figure 10, Items 2 and 3).

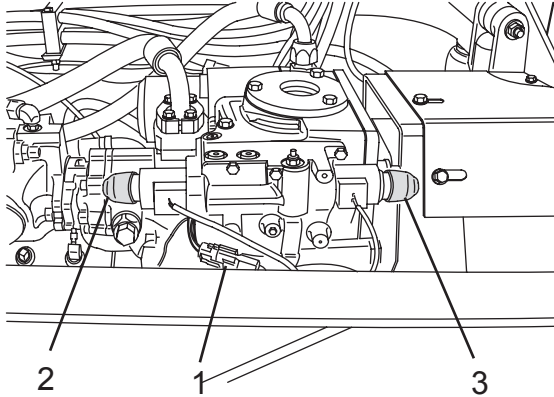

Figure 10

EP (Electric Proportional) Controls

8. Remove magnetic “DANGER” signs (Figure 11, Item 1) from both doors.
9. Unlock cab doors.
10. Remove and discard the steering wheel fastener.

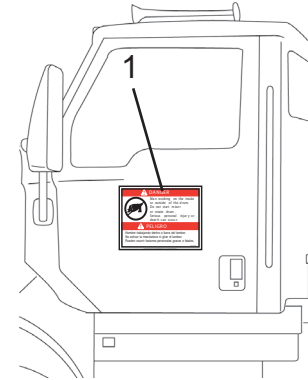

Figure 11

11. Remove all tools and other foreign objects from the area.
12. Check to make sure all mixer components (chutes, ladders, hoses, etc.) are properly stowed.
13. Inspect the area around the mixer system to make sure all people are clear before starting the Mixer.
14. Remove the wheel chocks or blocks from the front wheels before moving the truck.

1.1.2 Restoring Equipment to Normal Production Operations

1. After the servicing and/or maintenance is complete and the vehicle is ready for normal operations, check the area around the vehicle to ensure that no one is exposed.
2. After all tools have been removed from the vehicle, guards have been reinstalled and employees are in the clear, the employee who applied the LOCKOUT/TAGOUT device(s) will remove the device(s).
3. Notify all affected employees that the vehicle is being put in operation. Operate the energy-isolating devices to restore energy to the vehicle.

1.2 Battery Cable Disconnect

If the Mixer is not equipped with a battery disconnect switch, disconnect the negative (black) battery cable first, then disconnect the positive (red) cable.

WARNING

For trucks without a battery disconnect switch, to prevent accidental vehicle start-up, which could cause death or serious injury, disconnect battery cables (negative cable first) before proceeding.

Disconnect negative (-) battery cable first. If positive (+) cable should contact ground with negative (-) cable connected, the resulting sparks can cause a battery explosion, which could result in death or serious injury.

1.3 Safety Equipment

Some Revolution Mixer Trucks come equipped with a five pound fire extinguisher, which has a rating of B:C, and a reflective warning triangle kit containing three triangles.

The fire extinguisher may already be mounted to the Mixer, otherwise it is temporarily placed into the cab of your truck along with the reflective triangle kit.

If you are supplying your own fire extinguisher, it must comply with DOT FMCSA regulation 173.309 and 393.95 for rating and placement on the vehicle.

You are responsible for permanent mounting of this equipment. The fire extinguisher is required to be securely mounted to prevent sliding, rolling, or vertical movement. The mounting location of the reflective triangles is at your discretion.

1.4 Reporting Safety Defects

If you believe that your vehicle has a defect which could cause a crash or could cause injury or death, you should immediately inform the National Highway Traffic Safety Administration (NHTSA) in addition to notifying Revolution Concrete Mixers and the chassis manufacturer.

If NHTSA receives similar complaints, it may open an investigation, and if it finds that a safety defect exists in a group of vehicles, it may order a recall and remedy campaign. However, NHTSA cannot become involved in individual problems between you, your dealer, Revolution Concrete Mixers or the chassis manufacturer.

To contact NHTSA, you may call the Vehicle Safety Hotline toll-free at 1-888-327-4236 (TTY: 1-800-424-9153); go to <http://www.safercar.gov>; or write to: Administrator, NHTSA, 400 Seventh Street, SW., Washington, DC 20590. You can also obtain other information about motor vehicle safety from <http://www.safercar.gov>.

2.0 Product Safety Information

Safety notices are one of the primary ways to call your attention to potential hazards.



THIS SAFETY SYMBOL INDICATES IMPORTANT SAFETY MESSAGES IN THIS MANUAL.

WHEN YOU SEE THIS SYMBOL, CAREFULLY READ THE MESSAGE THAT FOLLOWS.

BE ALERT TO THE POSSIBILITY OF PERSONAL INJURY OR DEATH.

The following safety notices are used throughout this manual.

DANGER

Danger indicates an imminently hazardous situation which, if not avoided, will result in death or serious injury. Danger is used in the most extreme situations.

WARNING

Warning indicates a potentially hazardous situation which, if not avoided, could result in serious injury or death.

CAUTION

Caution indicates a situation that might result in property damage.

SAFETY NOTICE

OPERATOR'S INSTRUCTION

The signal words of DANGER, WARNING, and CAUTION have specific meanings to alert you to the relative level of hazard.

Take the safety warnings seriously. If you do not understand them or have questions about them, call Revolution Concrete Mixers.

2.1 Use Proper Safety Equipment

Always wear proper safety equipment/clothing while operating the Mixer.

Proper safety equipment includes:

- Hard Hat
- Safety Glasses or Goggles
- Snug-Fitting, Full-Covering Clothes
- Shirt with Tight-Fitting Long Sleeves (always keep shirt tails tucked in)
- Long Pants without Cuffs (Cuffs can be tripped over. Cuffs may also catch concrete)
- Steel-Toed Shoes or Boots
- Rubber Boots (if standing in concrete is required)
- Lime-Resistant Gloves
- Rubber Gloves (during clean-out)
- Hearing Protection
- Breathing Mask (if working in an area where cement dust is present)
- Breathing Apparatus and Ventilation Fan (if working in a Confined Space - see OSHA 1910.146)

Follow these guidelines to reduce risks of injury:

- Avoid wearing clothing that has long strings, fringes, or ties that can become caught in equipment
- Never wear jewelry (rings, necklaces, bracelets, wrist watches, etc.). These can become snagged on equipment or, if they come in contact with electrical circuits, can present a shock or burn hazard.
- Tie up long hair to prevent it from becoming caught in moving parts
- In cold weather, avoid wearing loose-fitting clothing. It is better to wear layers of clothing under a pair of snug-coveralls than a large, loose-fitting jacket or parka
- Keep work clothing clean and in good repair
- Keep the soles of your work boots clean and in good condition for traction when climbing on and off the vehicle/mixer system

3.0 Safety Information

Read, understand, and follow the safety guidelines and heed dangers and warnings listed below and contained in this manual as well as on the Mixer itself to promote reliable operation and prevent serious personal injury.

Contact Revolution Concrete Mixers if you require assistance or have questions.

3.1 Safety

WARNING

Safety decals must be replaced anytime they are damaged, missing, or cannot be read clearly. Failure to have proper decals in place can result in serious injury or death. If you require safety decals, please contact Revolution Concrete Mixers.

WARNING

The mixer vehicle must not be modified in any way without authorization from Revolution Concrete Mixers. Modifications may not comply with safety standards, including ANSI safety standards. Failure to comply may result in serious personal injury or death.

WARNING

Wear Personal Protective Equipment (PPE) such as hard hats, hearing protection, steel toed boots, and snug fitting sturdy long-sleeve shirt and long pants when operating or maintaining the vehicle. Reflective clothing is recommended for drivers and employees while operating the vehicle during hours of darkness. Failure to comply may result in serious personal injury or death.

WARNING

Operating, servicing, and maintaining this vehicle or equipment can expose you to chemicals including exhaust, carbon monoxide, phthalates, and lead, which are known to the state of California to cause cancer and birth defects or other reproductive harm. To minimize exposure, avoid breathing exhaust, do not idle the engine except as necessary, service your vehicle or equipment in a well ventilated area and wear gloves or wash hands frequently when servicing. For more information, go to www.p65warnings.ca.gov.

CAUTION

Fire Hazard. If vehicle is equipped with a battery disconnect switch, it must be turned off anytime the equipment is parked overnight, in a shop, or out of service for any extended period of time. Failure to comply may cause damage to property or equipment.

3.2 Cab Operation

DANGER

If the mixer vehicle comes into contact or close proximity with a power line or there is any arcing,

- stay in the vehicle cab
- keep away from metal parts of the vehicle
- do not let anyone come close to the vehicle
- do not attempt to jump clear of the vehicle
- the power company must disconnect the power before you can safely leave the cab

Minimum clearance from power lines:

50,000 Volts or Less 4 Feet

- Know the clearance of overhead obstructions
- Never drive the mixer vehicle under any overhead obstruction

Failure to comply will result in serious personal injury or death.

 WARNING

Crush Hazard. Never walk or stand behind vehicle while it is backing up. Failure to comply may result in serious personal injury or death.

 WARNING

Crush Hazard. The operator and anyone working in the area of the Mixer should understand the meaning of all audible alarms and warning lights. Failure to comply may result in serious personal injury or death.

 WARNING

Crash Hazard. Make sure the area behind the truck is clear of people or obstructions before raising or lowering the Bridgmaster® trailer. The alarm in both the cab and at the rear of the mixer sounds when the trailer is traveling up or down. Keep clear of the area behind the truck and of the trailer pinch points while the trailer is in motion. Failure to comply may result in serious personal injury or death.

 WARNING

Crush Hazard. Remain attentive at all times when operating the controls. Be sure everyone is clear of the area around the truck before operating the Mixer. Thoroughly understand the controls before operating the vehicle. Failure to comply may result in serious personal injury or death.

 WARNING

Crash Hazard. No occupant is allowed in the cab unless a manufacturer's approved passenger seat and seat belt are provided. Failure to comply may result in serious personal injury or death.

 WARNING

Roll-over Hazard. The Mixer vehicle and the chassis must not be overloaded. Do not exceed the manufacturer's gross vehicle weight. Gross weights must meet federal, state, and local laws. Failure to comply may result in serious personal injury or death.

WARNING

High Pressure Fluid Hazard. Never drive the truck with the water tank pressurized. Failure to comply may result in serious personal injury or death.

WARNING

At the job site, use the lowest transmission gear and proceed at low speed, 3 mph (4.8 km/h) maximum, to the discharge area. Failure to comply may result in serious personal injury or death.

3.3 Outside Operation

WARNING

Air chute lock is intended for use only on the job site. The manual chute lock should always be engaged during transport. Excessive wear or injury may result due to improper usage. Failure to comply may result in serious personal injury or death.

WARNING

Burst Hazard. Never pressurize water tank in excess of 55 psi (380 kPa). If pressure exceeds 55 psi (380 kPa), depressurize the water tank immediately and adjust or replace the air regulator valve. Failure to comply may result in serious personal injury or death.

WARNING

Burst Hazard. Never pressurize an empty water tank. Failure to comply may result in serious personal injury or death.

 **WARNING****IMPORTANT ALUMINUM AND STEEL WATER TANK INFORMATION.**

1. Inspect water tank on a daily basis for any damage including, but not limited to, dents, gouges in metal, or leaks.
2. Do not weld on or repair water tank. Instead, replace water tank with a new OEM water tank.
3. Never pressure test an empty water tank. Only pressure test a full water tank.
4. Never remove pressure regulator or pressure safety valve from tank.
 - If regulator or safety valve is defective, it must be replaced before Mixer is put into service.
5. Do not pressurized water tank beyond its working pressure.
 - If pressure exceeds the working pressure, immediately depressurize water tank and replace pressure regulator and pressure safety valve.

6. Never drive the truck with the water tank pressurized.
 - Depressurize water tank prior to transit to or from job site.
 - Water tank should be pressurized only when being used.
7. Never modify water tank in any way.
8. Immediately replace safety decals with OEM decals if decals are missing or difficult to read.
9. Refer to the Revolution Operator's Manual or contact Revolution at (855) 202-6491 if you have questions or require assistance.

 **WARNING**

NEVER drink the water from a water tank. The water tank may contain residue from chemicals used to modify concrete properties. Failure to comply may result in serious personal injury or death.

WARNING

Fall Hazard. Use the three-point contact method (either two hands and one foot, or two feet and one hand on the ladder at all times) when climbing the ladder. Always face the ladder when climbing up or down. Failure to comply may result in serious personal injury or death.

WARNING

Fall Hazard. Do not climb on ladders or ride on platforms (if equipped with either) while the truck is in motion or when ladders or platforms are wet and slippery. Failure to comply may result in serious personal injury or death.

WARNING

Crush Hazard. Never walk or stand behind vehicle while it is backing up. Failure to comply may result in serious personal injury or death.

WARNING

Crush Hazard. Do not wear watches, rings, and jewelry while working with electrical and mechanical equipment. These items can be hazardous and can cause serious and painful injuries if they come into contact with electrical wires, moving parts, or hydraulic equipment. Failure to comply may result in serious personal injury or death.

WARNING

Pinch Hazard. Always keep hands and feet clear of the Mixer drum, revolving parts, and moving parts at all times. Failure to comply may result in serious personal injury or death.

WARNING

Roll-over Hazard. The Mixer must not be overloaded. Load pressures must match the load to be transported. Failure to comply may result in serious personal injury or death.

⚠️ WARNING

Crush Hazard. All personnel must stand clear of the chutes during raising and lowering, and when chutes are loaded with concrete. Position chutes while they are not loaded. A loaded chute falling on a person may cause serious injury. All chutes must be handled with great care to avoid injury. Do not stand on chutes. Failure to comply may result in serious personal injury or death.

⚠️ WARNING

Crush Hazard. Do not let persons, other than the driver, handle the chutes, unfold the foldover, and/or remove extension, or stow and secure the extensions for transit. Keep hands away from chute hardware where the chutes connect. Never stand in the path of the chute as it is being unfolded or while in use. Failure to comply may result in serious personal injury or death.

⚠️ WARNING

Wear Personal Protective Equipment (PPE) such as hard hats, hearing protection, steel toed boots, and snug fitting sturdy long-sleeve shirt and long pants when operating or maintaining the vehicle. Reflective clothing is recommended for drivers and employees while operating the vehicle during hours of darkness. Failure to comply may result in serious personal injury or death.

⚠️ CAUTION

Fall Hazard. Do not use the water tank as a step. Failure to comply may cause damage to property or equipment.

⚠️ CAUTION

Crush Hazard. Do not use more chute extensions than are specified for your Mixer. Do not use any other type or style of chute extensions, other than ones designed for use with your Mixer. Failure to comply may cause damage to property or equipment.

3.4 Maintenance

SAFETY NOTICE

Perform your company's Lockout/Tagout procedure. If your company does not have a Lockout/Tagout procedure, follow OSHA 1910.147 and 1910.146 Confined Space as appropriate.

DANGER

Crush Hazard. LOCKOUT/TAGOUT procedures must be followed when working on this equipment. Failure to comply will result in serious personal injury or death.

DANGER

Crush Hazard. Do not attempt to use extraneous sources of power or extraneous machines to overcome a malfunctioning system. Contact Revolution Concrete Mixers if you are unsure how to proceed. Do not override with overhead cranes, forklifts, jacks, etc., or jury-rig systems or equipment that may be malfunctioning. Failure to comply will result in serious personal injury or death.

WARNING

The mixer vehicle must not be modified in any way without authorization from Revolution Concrete Mixers. Modifications may not comply with safety standards, including ANSI safety standards. Failure to comply may result in serious personal injury or death.

WARNING

Daily inspections should be performed on the mixer vehicle. This includes

- proper operation of the controls
- hydraulic system
- electrical system
- pneumatic system
- structural components

Correct all identified deficiencies BEFORE operating the mixer vehicle. Failure to correct deficiencies may cause damage to equipment. Failure to comply may result in serious personal injury or death.

⚠ WARNING

Main, fold-over, and extension chutes must be inspected on a daily basis for damage, excessive wear, proper hardware fit, twist, and overall condition to determine that they are safe to use. Unsafe chutes must be replaced with new chutes. Failure to comply may result in serious personal injury or death.

⚠ WARNING

Always check body/vehicle lights on the chassis or on the vehicle body. (Note: Not all models have indicator lights.) Replace bulbs or lights when required. Failure to inspect lights may lead to more serious conditions. Failure to comply may result in serious personal injury or death.

⚠ WARNING

Exceeding axle gross weight will result in premature brake wear and reduced brake performance. Inspect and adjust chassis brake as per the chassis manufacturer's recommendations. Failure to comply may result in serious personal injury or death.

⚠ WARNING

Never enter under the chassis unless the Mixer is in the Lockout mode. Remember to follow the Lockout procedures when working under the truck. Failure to comply may result in serious personal injury or death.

⚠ WARNING

When working on the Mixer, the wheels must be blocked, the parking brake on, LOCKOUT procedure in effect, and the keys out of the truck's ignition. Failure to comply may result in serious personal injury or death.

⚠ WARNING

Burst Hazard. Do not repair or weld on steel or aluminum water tanks. Inspect the water tank for rust and corrosion every 30 days. Inspect the water tank under the straps, on the exterior and interior by removing the flopper. If any rust or corrosion is found, replace the water tank with an OEM water tank from Revolution. Contact Revolution Concrete Mixers with questions. Failure to comply may result in serious personal injury or death.

3.5 Hydraulics

WARNING

High Pressure Fluid Hazard. Hydraulic hoses and tubes must be inspected on a daily basis. If you find hoses with damage, they must be replaced before the vehicle is returned to service. Failure to comply may result in serious personal injury or death.

WARNING

Burn Hazard. Hydraulic systems are hot. **DO NOT TOUCH!** Serious personal injury or death may result from hot oil. Failure to comply may result in serious personal injury or death.

WARNING

Crush Hazard. The hydraulic cylinders can be holding a function in a certain position when the engine is OFF. Block and secure all applicable devices and functions before beginning work or operation. Failure to comply may result in serious personal injury or death.

WARNING

High Pressure Fluid Hazard. All hydraulic pressure must be relieved from the hydraulic system prior to removing any components from the system. Failure to comply may result in serious personal injury or death.

WARNING

High Pressure Fluid Hazard. Hydraulic systems operate under high pressure. Only qualified, experienced people properly trained in hydraulic system maintenance should attempt repairs or troubleshoot hydraulic systems. Failure to comply may result in serious personal injury or death.

Please contact Revolution at (855) 202-6491 if you require assistance.

 WARNING

Never alter the original equipment manufacturer's design. Hydraulic pressures and component functioning speeds are set before the vehicle is shipped to the customer. Failure to comply may result in serious personal injury or death and void the mixer vehicle warranty.

 WARNING

When using the emergency jumper procedure to rotate the drum on a disabled Mixer, the following must be observed: Before removing the hydraulic motor or hoses from the Mixer drive on both the operating and disabled Mixer, be sure the drum has been allowed to turn freely so that it is balanced with no forces transmitted to the hydraulic motor. Failure to comply may result in serious personal injury or death and void the mixer vehicle warranty.

3.6 Electrical

 WARNING

Unintended Motion Hazard. Proximity switches must remain functional for safe operation of the mixer vehicle. If a switch does not work or has been tampered with or damaged, it must be replaced immediately with an OEM switch before the mixer vehicle returns to service. Failure to comply may result in serious personal injury or death. Contact Revolution at (855) 202-6491 for assistance if required.

 WARNING

Always check body/vehicle lights on the chassis or on the vehicle body. (Note: Not all models have indicator lights.) Replace bulbs or lights when required. Failure to inspect lights may lead to more serious conditions. Failure to comply may result in serious personal injury or death.

3.7 Chute Extensions

WARNING

Do not repair metal or composite chute extensions. Failure to comply may result in serious personal injury or death.

WARNING

Do not over-load chute extensions. Maximum load capacity of 400 lbs. per chute extension. Failure to comply may result in serious personal injury or death.

DANGER

Crush Hazard. Chute extensions must be secured on the truck before leaving the job site. Failure to comply will result in serious personal injury or death.

CAUTION

Crush Hazard. Do not use more chute extensions than are specified for your Mixer. Do not use any other type or style of chute extensions, other than ones designed for use with your Mixer. Do not combine the use of metal and composite chute extensions during operational use. Failure to comply may cause damage to property or equipment.

WARNING

Inspect chute extensions prior to each use. Never use a damaged chute extension or a chute extension that has been driven over. Replace damaged chutes extensions immediately. Failure to comply may result in serious personal injury or death.

CAUTION

Never clean chute extensions by striking or chiseling. Failure to comply may cause damage to property or equipment.

 **DANGER**

Crush Hazard. Never stand on a chute or chute extensions. Do not use the chute as a crane to pull or transport objects. Failure to comply will result in serious personal injury or death.

 **DANGER**

Flammable Hazard. Any urethane parts are flammable. Do not expose to an open flame or a temperature exceeding 220°F (104°C). Burning chute extensions produce toxic smoke/fumes during combustion. Failure to do so will result in serious personal injury or death.

1.0 Exterior Systems Arrangement

1.1 Curb Side View

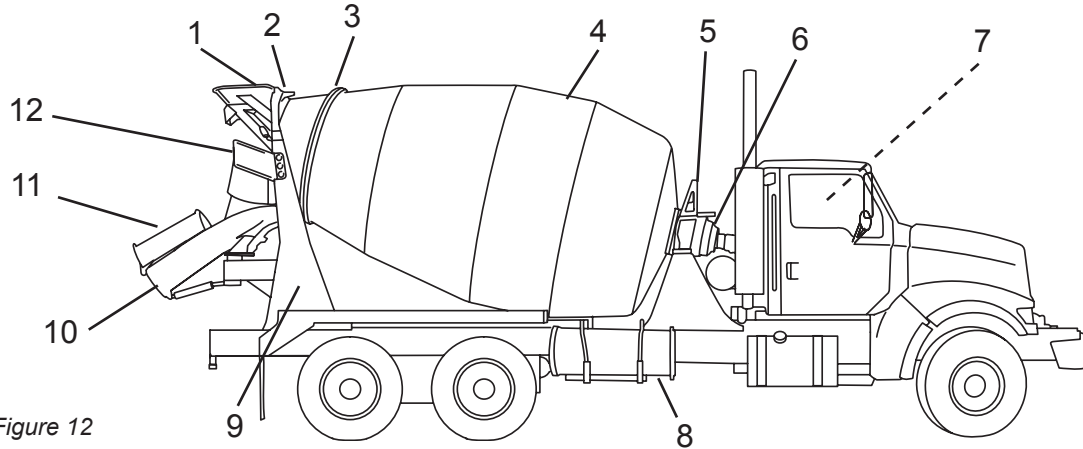

Figure 12

Ref No.	System Description
1	Charge Hopper
2	Debouncer
3	Drum Roller Track (Ring)
4	Drum
5	Hydraulic Oil Cooler (Location May Vary)
6	Drum Drive

Ref No.	System Description
7	Cab Control Box
8	Chute Extensions (Location May Vary)
9	Rear Pedestal
10	Main Chute
11	Fold-Over Chute
12	Collector

1.2 Street Side View

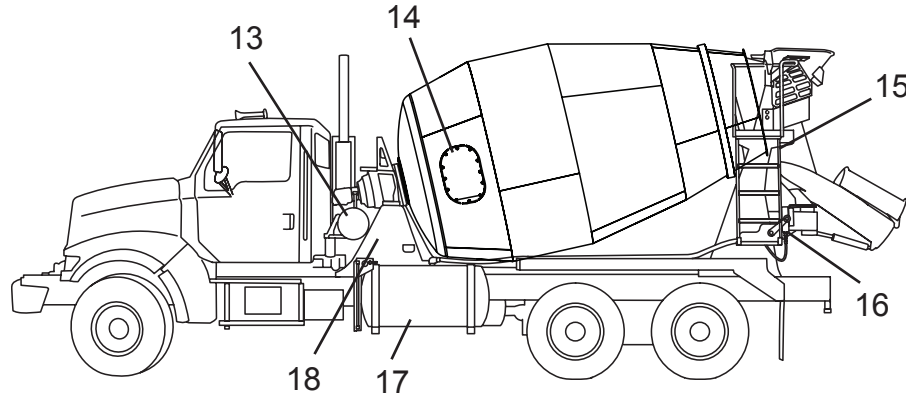

Figure 13

Ref. No.	System Description
13	Hydraulic Oil Reservoir (Location May Vary)
14	Drum Hatch
15	Drum Access Ladder
16	Rear Control Pendant
17	Water Tank (Location May Vary)
18	Front Pedestal

1.0 Before Placing the Mixer Into Service

After delivery, it will be necessary to prepare the Mixer for normal operation.

1. Remove cable ties securing the access ladder.
2. Deactivate the Transport Lock.
3. Securely mount the emergency equipment.
 - a. Mount the fire extinguish in an area that is readily accessible, and in a manner that prevents sliding, rolling, or vertical movement.
 - b. The mounting location of the triangle kit and spare fuse kit is at the discretion of the final user.
4. Attach and securely stow wash-out hose(s).
5. Inspect all mounting hardware to see if any has loosened during delivery. Retighten hardware as needed.
6. Inspect all hydraulic lines and hoses for leaks.
7. Charge the Mixer with a quantity of stone and sand. Rotate the drum for 1-1/2 to 2 hours to clean the interior of any weld slag or splatter. This will polish the blades and reduce the possibility of concrete adhering to the drum interior.

1.1 INSIGHT System Deactivate Transport Feature

The system is programmed with a transport feature that commands the drum to rotate in the charge direction at approximately 1 to 1-1/2 RPM whenever the chassis engine is running. This feature is required to prevent damage to the drum rollers during delivery.

NOTE

After the chassis engine start, there may be a slight delay before drum rotation starts in the CHARGE direction.

The transport feature is deactivated and activated through the touch screen control display (Figure 14).

1. Enter the Fleet Manager Code. Contact Revolution at (855) 202-6491 to receive the code.
2. Touch the ENTER PASSWORD TO UNLOCK button.

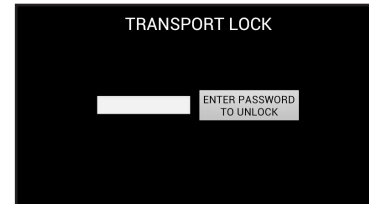

Figure 14

1.2 Traditional Controls Deactivate Transport Feature

1. Remove the cable tie (Figure 15, Item 1) securing the hydraulic pump linkage in the TRANSPORT mode. The TRANSPORT mode constantly rotates the drum in the CHARGE direction at a speed of 1 to 1-1/2 RPM. This prevents the drum rollers from becoming damaged during transport.
2. Install the cab chute control fuse.

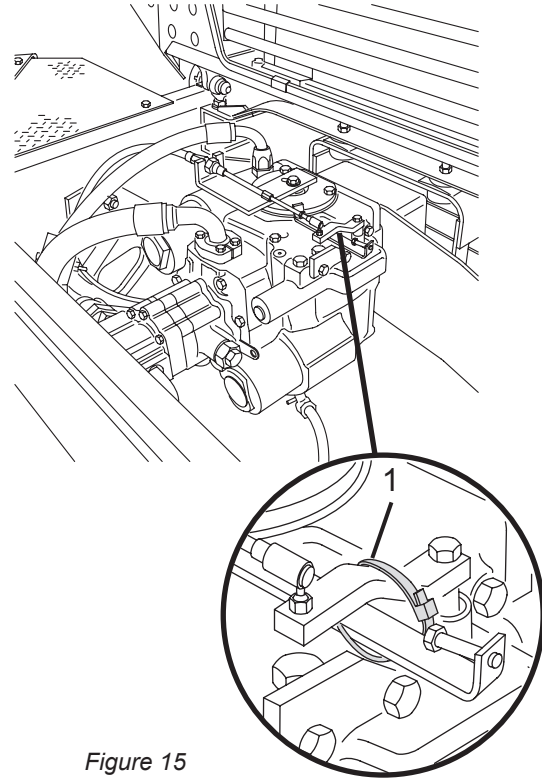

Figure 15

2.0 INSIGHT Mixer System Instruments and Controls

The following figures and tables identify and describe the controls used on this equipment. These instructions include optional features that may or may not be included on your Mixer.

To make sure you understand proper operating procedures, read this section and carefully practice with the controls and instruments to learn how to safely operate the equipment. The INSIGHT Mixer System consists of a monitor (Figure 16) that has indicator icons to display the status of functions.

2.1 Home/Drum Screen Overview

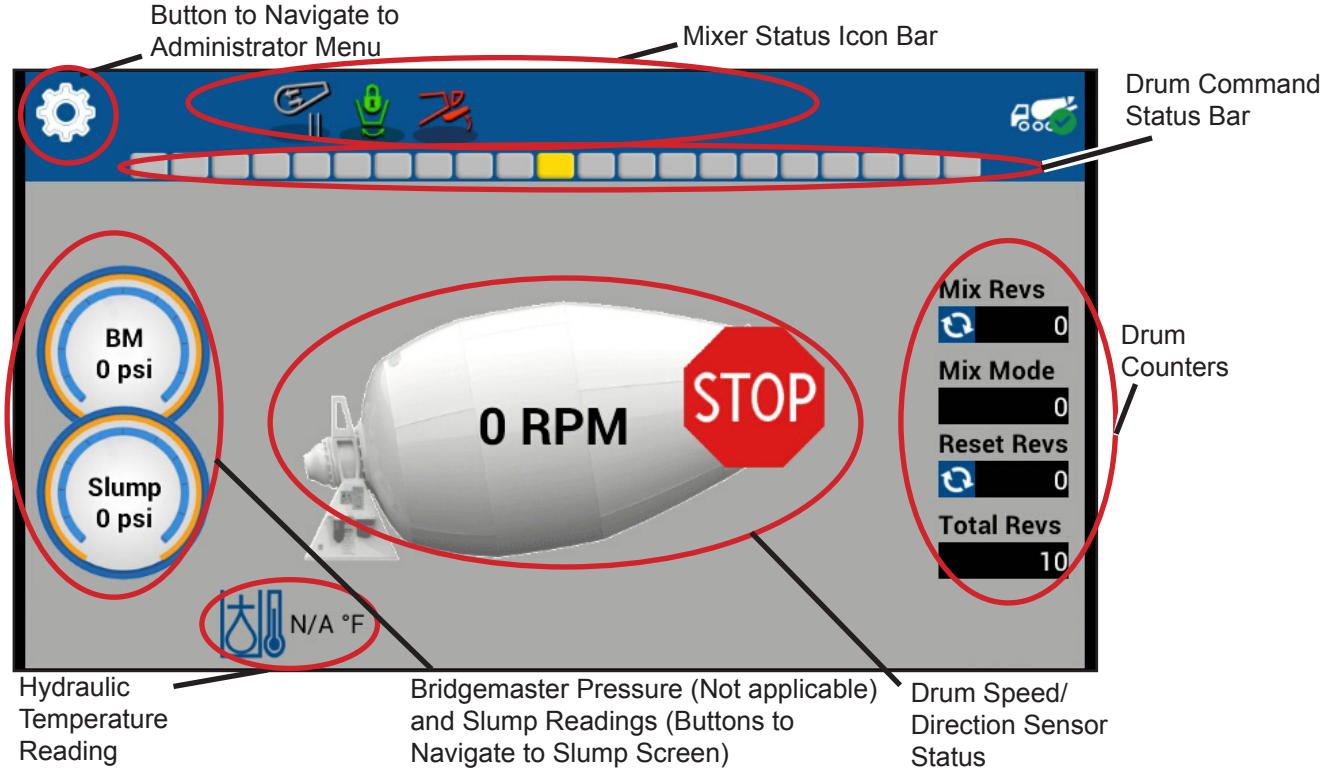
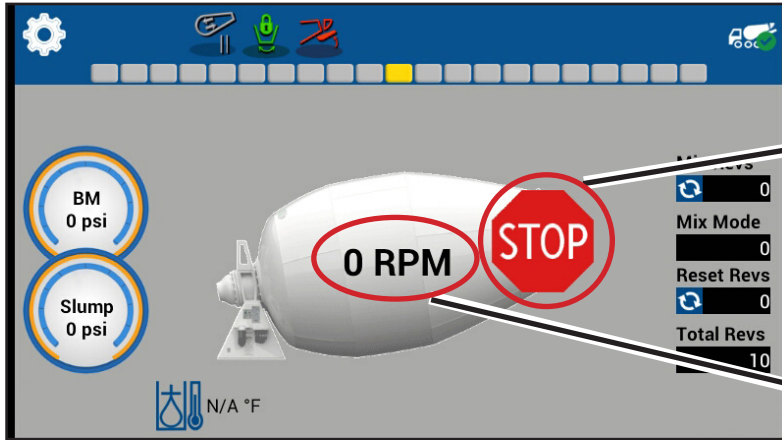

Figure 16

2.2 Speed/Direction Sensor Reading Screen Overview



Signifies the Drum's Direction based on Sensor's Reading

Signifies the Drum's Speed Based on Sensor's Reading

Direction: Charge
Speed: 4.8 Drum RPM

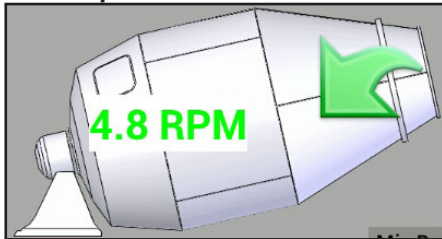

Direction: Stopped
Speed: 0 Drum RPM

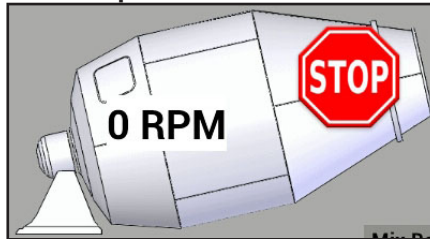

Direction: Discharge
Speed: 1.3 Drum RPM

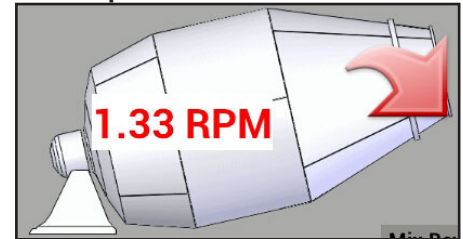

Figure 17

2.3 Drum Revolution Counter Screen Overview

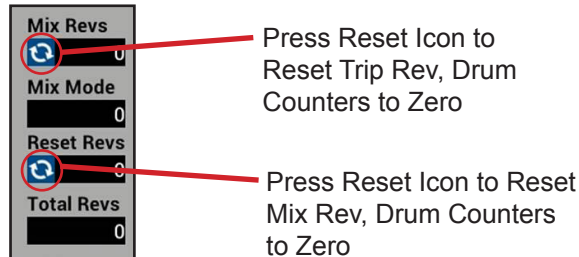
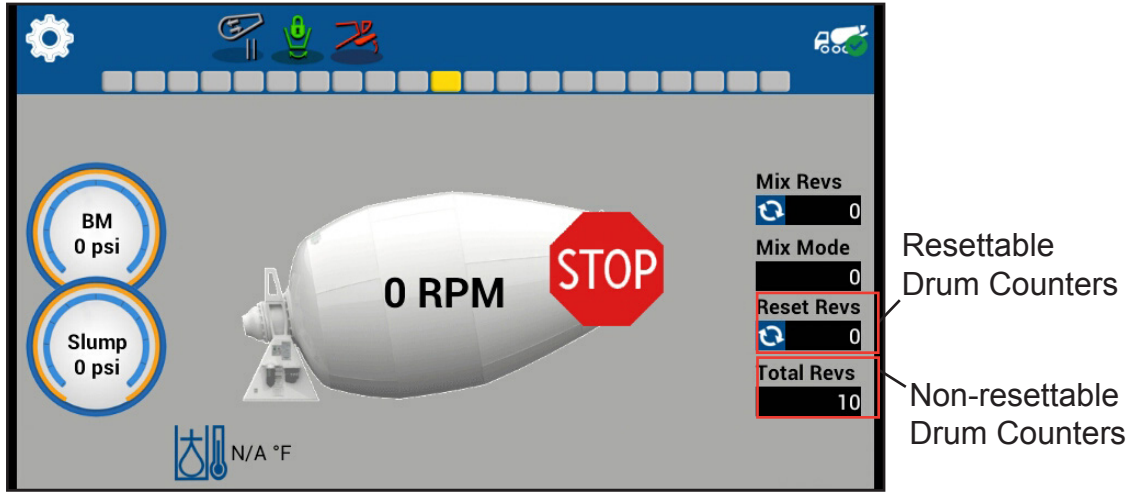

Figure 18

2.4 Auxiliary Function Icons

These instructions include optional features that may or may not be included on your Mixer.

Press the icon to enable or disable the auxiliary function.

- Remote PTO mode (Figure 19, Item 1). The icon will be grayed out if not turned on.
- Hydraulic Fan (this function is already engaged if the temperature is over 140°F) (Figure 19, Item 2). The icon will be grayed out if not turned on.
- Work Lights ON in Reverse (Figure 19, Item 3). Use work lights on in reverse at a job site only. Using work lights on in reverse while on the roadway is not recommended and may not comply with applicable laws. The icon will be grayed out if not turned on.

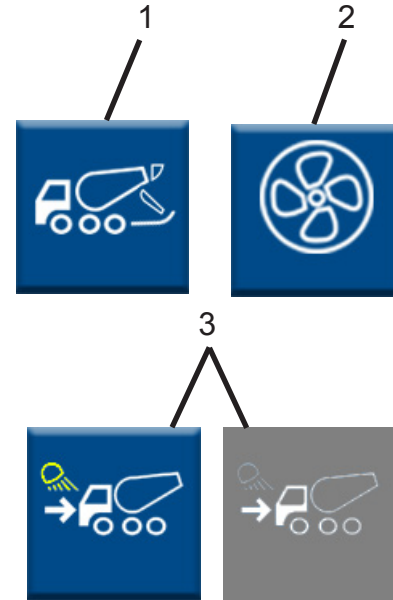

Figure 19

Operation

2.4.1 INSIGHT System Enabled Package

NOTE: Not all INSIGHT System mixers are equipped with all features. INSIGHT System Enabled Packages are available to add features not included in our base model of INSIGHT System.

Constant Speed Modes

Constant Speed Modes will control the number of drum revolutions when activated. These presets can be changed within the Fleet Manager Mode.

- Empty (Figure 20, Item 1). Spins the drum at 1 RPM in Constant Speed.
- Wet (Figure 20, Item 2). Spins drum at 5 RPM Low Constant Speed and 12 RPM High Constant Speed.
- Standard (Figure 20, Item 3). Spins drum in two configurable constant speeds (Low: 1-3 RPM; High: 3.1-7 RPM).
- Dry (Figure 20, Item 4). Spins the drum at 1.5 RPM in Constant Speed.

Mix Modes

- Mixing Admix (Figure 20, Item 5). Throttles up the truck to mixing speed and mixes for 30 revolutions before returning to Constant Speed.

- Mixing Water (Figure 20, Item 6). Throttles up the truck to mixing speed and mixes for 70 revolutions before returning to Constant Speed.

Drum Reactivity Modes

- Smooth (Figure 20, Item 7). Allows drum to transition to new direction/velocity with dampening to minimize wear. This is the recommended operating mode.
- Legacy (Figure 20, Item 8). Allows quick transition (faster transition than “Smooth”) to new direction/velocity without dampening.

Auxiliary Functions

- Admixture (Figure 20, Item 9). Allows addition of prescribed amount directly into drum, and record amount added and time of addition.
- Buildup (Figure 20, Item 10). Starts a buildup test on the drum to determine if there is ~2000 lbs. of buildup. The system performs the drum test controlling the drum for approximately one minute. The system then prompts the operator: No buildup detected; Test conditions not met; Possible buildup. Test should be performed on a regular schedule for the most accurate reading. Revolution recommends once daily.

- Washout (Figure 20, Item 11). Allows selection of up to 4 washout zones. Each zones will wash for predetermined set of time.
- Water (Figure 20, Item 12). Allows addition of prescribed amount of water directly into the drum, records amount added, and time of addition.
- Slump Calibration (Figure 20, Item 13). This screen is used to load and save slump calibrations. These values are used for the inch readouts for the Slump gauges used on the Drum and Slump screens. See 11.12 Concrete Slump Meter and 11.12.2 Setting the Digital Concrete Slump Meter for INSIGHT System Only for more information.
- Auto Load Mode (not shown). The system will monitor the hydraulic pressure until a pressure increase is detected and then change to Load Mode (increasing drum RPM to load mode speed using throttle control). Auto Load can be actuated by simultaneously pressing the unlock key and load key.
- GradeGuard (optional feature) (not shown). When the mixer is equipped with GradeGuard, drum will switch to high Constant Speed when the mixer detects it is climbing greater than 4% grade.

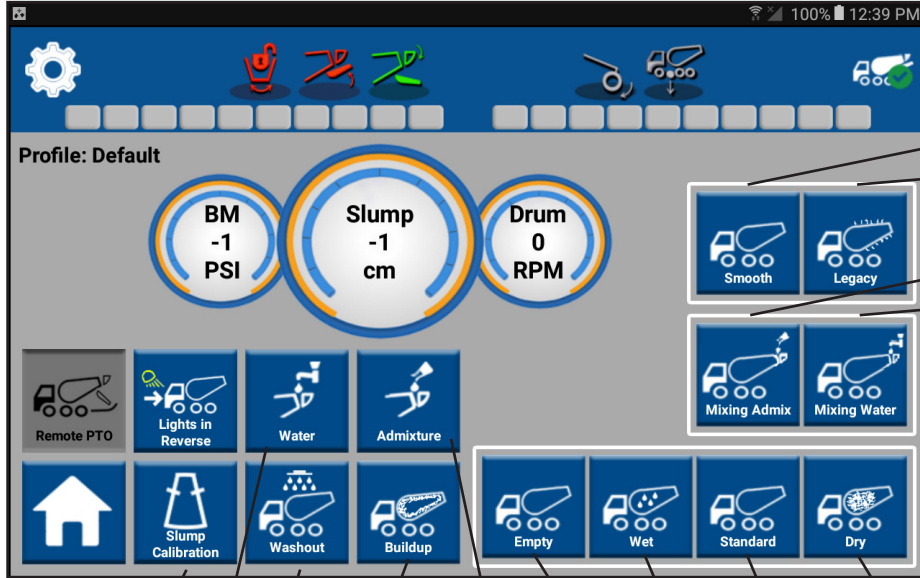

Figure 20

2.5 Touch Screen Display Button Overview

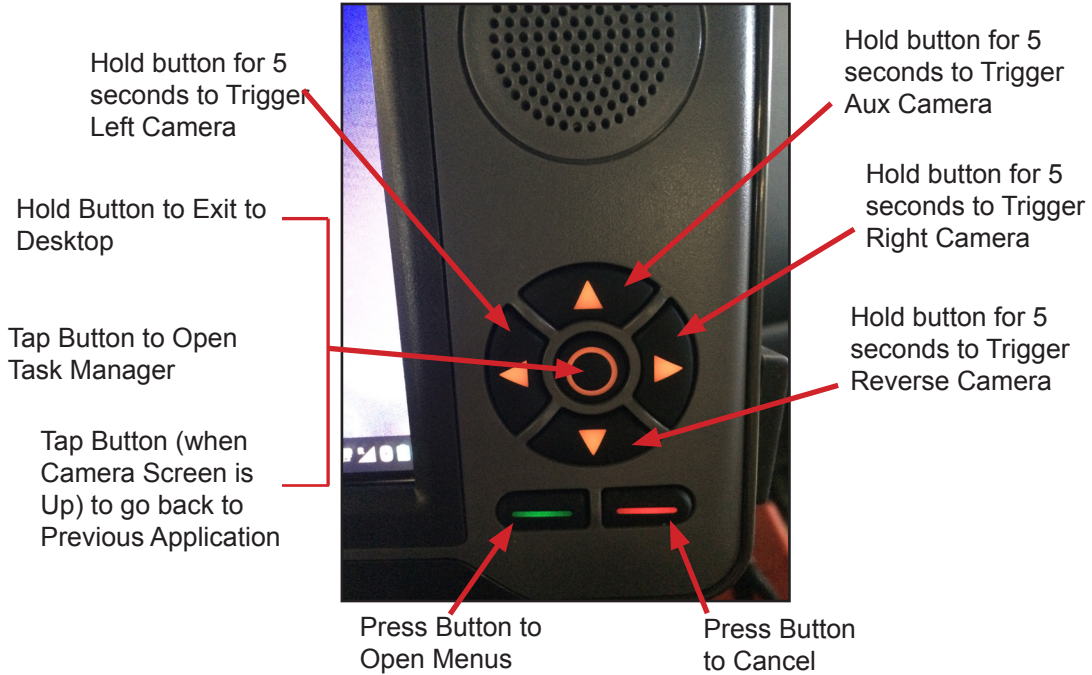

Figure 21

Operation

2.6 Touch Screen Display Status Icons



Chute Locked



Chute Unlocked



Chute Down



Chute Up



Drum Charge



Drum Discharge



Hopper Up



Hopper Down



Load Mode



Mix Mode



Work Lights On



Strobe Lights On



Add Water (Optional Equipment)



AdMix (Optional Equipment)



Hydraulic Temperature



Hydraulic Fan

2.7 Cab Control Keypad (Standard)

The in-cab controls consist of a control keypad and an optional joystick (Figure 22). Accessories and mixer functions and some options are operated by buttons on the cab control keypad (Figure 22). The actual buttons present on the control keypad will vary, depending on the configuration of your Mixer.

No.	Item	Description
1	Strobe Lights	LED on when strobe lights are ON. Press to turn on or off.
2	Perimeter Lights	LED on when perimeter lights are ON. Press to turn on or off.
3	Work Lights	LED on when work lights are ON. Press to turn on or off.
4	Hopper Up/ Down	Green LED when air hopper is DOWN. Red LED when air hopper is UP.
5	Chute Up	Green LED while button is pressed.
6	Pusher Axle Up	Green LED while button is pressed.
7	Chute Lock/ Unlock	Green LED when locked and Red LED when unlocked.

Operation

No.	Item	Description
8	Chute Down	Green LED while button is pressed.
9	Pusher Axle Down	Green LED while button is pressed.
10	Drum Pause/Resume*	Stops the drum rotation.
11	Chute Swing Left	Moves chute to the left (Power Chute Swing Option only). Green LED is on when button is pressed.
12	Chute Swing Right	Moves chute to the right (Power Chute Swing Option only). Green LED is on when button is pressed.

* Mixers with Cable Control will have this function if they have the Start/Stop valve.

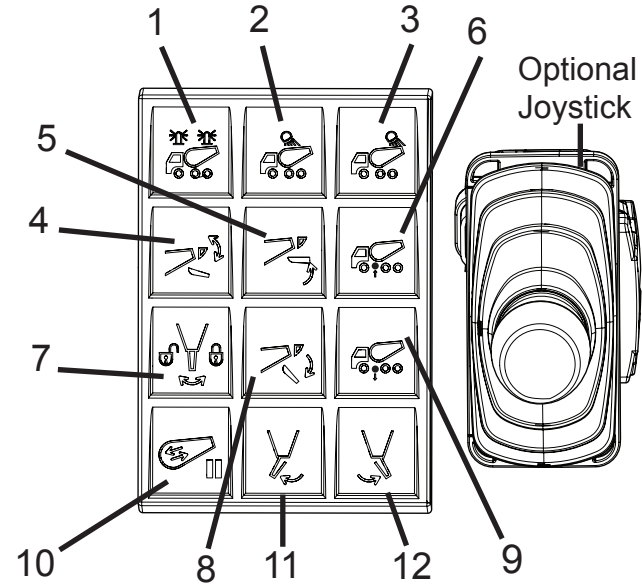

Figure 22

2.8 Cab Control Keypad (Optional)

The optional in-cab keypad controls some accessories and mixer functions (Figure 23). The actual buttons present on the control keypad will vary, depending on the configuration of your Mixer.

No.	Item	Description
1	Constant Speed Mode*	LED is green when in constant speed mode. Constant speed will automatically engage if going over preset speed.
2	Mix Mode*	Turns drum at preset speed for a preset number of revolutions by ramping engine speed. Truck must be in Park/Neutral, parking brake must be set to active, and Cruise Control Switch turned on.
3	Load Mode*	Turns drum at maximum speed for loading purposes by ramping engine speed. Truck must be in Park/Neutral, parking brake must be set to active, and Cruise Control Switch turned on.

No.	Item	Description
4	Tag Axle Up	LED on when Tag Axle is UP.
5	Activate	Press and hold the button and Tag function buttons.
6	AdMixture Add	LED on when AdMixture Add button is pressed.
7	Tag Axle Down	LED on when Tag Axle is DOWN.
8	Bridgemaster Axle Pause/Resume	Not applicable.
9	Water Add	LED on when add water is enabled.
10	Joystick Enabled/Disabled	Indicates if joystick is enabled (green) or disabled (red).
11	Drum Charge*	LED is green while charging.
12	Drum Discharge*	LED is green while discharging.

* Mixers with Cable Control will not have this function.

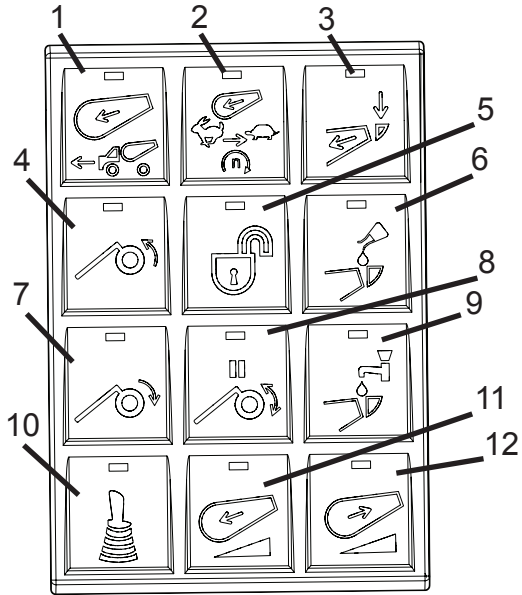

Figure 23

2.9 Joystick for Chute Lock/Unlock, Chute Up/Down Functions

The Mixer may be equipped with an optional joystick that controls chute lock/unlock, main chute up, and main chute down (Figure 24). If equipped, this joystick is found as part of the in-cab control box.

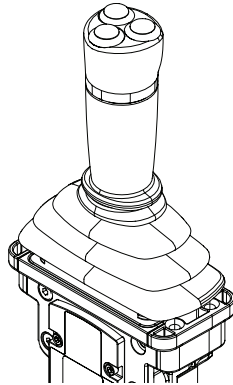
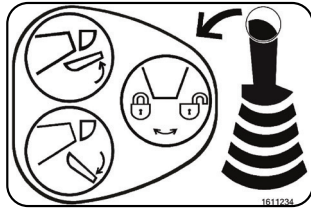
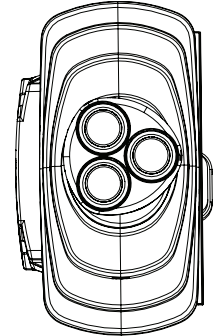

Figure 24



Move the joystick forward for Charge. The green LED indicator lights up to the left on the touch screen display. Valve position proportionally affects drum speed.

Move the joystick backward for Discharge. The red LED indicator lights up to the right on the touch screen display. Valve position proportionally affects drum speed.

Figure 25

Operation

2.10 Outside Controls

The outside controls consist of a rear pendant keypad (Figure 26, Item 1), a manual chute lock (Figure 26, Item 2), and a cable drum control for cable control mixers only (Figure 26, Item 3).

No.	Item	Description
1	Rear Control Pendant Keypad	Contains digital push buttons to control various mixer functions.
2	Manual Chute Lock	Mechanically locks the discharge chute in one of several positions.
3	Cable Drum Control	For Cable Drum Control Mixers Only. Drum charge, discharge, and stop are controlled by the cable.

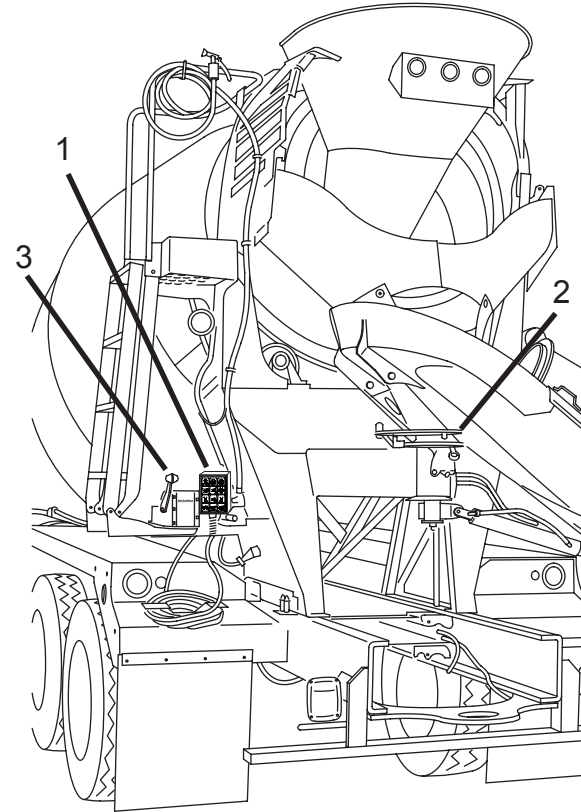

Figure 26

2.10.1 Rear Pendant Control Keypad

Accessories and mixer functions and some options are operated by buttons on the rear control pendant keypad (Figure 27). The actual buttons present on the control pendant will vary, depending on the configuration of your Mixer. The operator can take the rear pendant up the ladder platform for quick access to starting and stopping the drum.

No.	Item	Operation
1	E-STOP	E-STOP on/off button.
2	Throttle Down	Slows the engine throttle. Truck must be in Park/Neutral, parking brake must be set to active, and Cruise Control Switch turned on.
3	Throttle Up	Speeds engine throttle. Truck must be in Park/Neutral, parking brake must be set to active, and Cruise Control Switch turned on.
4	Hopper Up/Down	Green LED when air hopper is DOWN. Red LED when air hopper is UP.

No.	Item	Operation
5	Chute Up	Green LED while button is pressed.
6	Chute Lock/Unlock	Green LED when locked and Red LED when unlocked.
7	Chute Swing Left	Moves chute to the left (Power Chute Swing Option only). Green LED is on when button is pressed.
8	Chute Down	Green LED while button is pressed.
9	Chute Swing Right	Moves chute to the right (Power Chute Swing Option only). Green LED is on when button is pressed.
10	Drum Stop*	Stops drum rotation.
11	Drum Charge**	Speeds drum while charging and slows drum while discharging. Green LED while charging.
12	Drum Discharge**	Speeds drum while discharging and slows drum while charging. Green LED while discharging.

Operation

* Mixers with Cable Control will have this function if they have the Start/Stop valve.

** Mixers with Cable Control will not have this function.

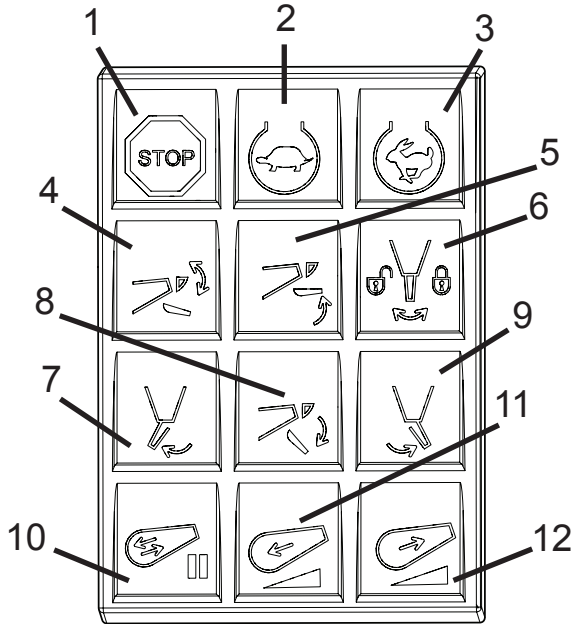

Figure 27

2.10.2 Cable Drum Control (If Equipped)

The rear drum control by cable (Figure 28).

No.	Control	Normal Use or Reading
1	DRUM CONTROL LEVER (CHARGE/DISCHARGE)*	Starting at the NEUTRAL position, pushing the lever forward (away from the operator) starts the drum rotating in the CHARGE direction. The farther the lever is pushed forward, the faster the drum rotates. Pulling the lever back (toward the operator) will decrease the drum speed until the NEUTRAL position is reached at which point the drum stops rotating. From the NEUTRAL position, pulling lever back (toward the operator) will start the drum rotating in the DISCHARGE direction. The farther the lever is pulled back, the faster the drum rotates.

* Mixers with Electronic Drum Control will not have this function.

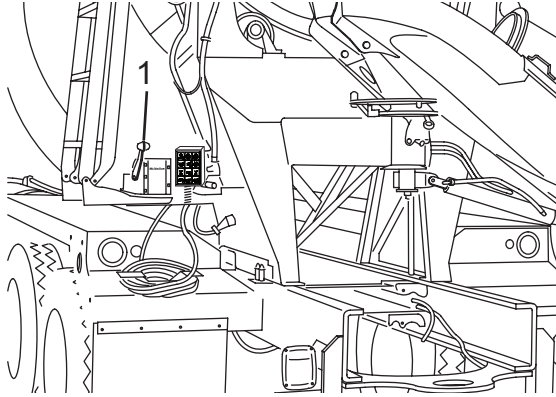

Figure 28

2.10.3 Manual Chute Lock

CAUTION

Do not move the vehicle without locking the chute with the manual chute lock. Do not use the chute air lock to secure the chute for transport.

Driving the vehicle without the chute properly locked may cause damage to equipment.

The manual chute lock mechanically locks the chute in one of several pre-determined positions.

To move the chute:

1. Unlock the chute air lock (if equipped).
2. While holding the chute, pull down on the lever (Figure 29, Item 1) and move it to the right or left until the lever is seated in one of the lock positions.
3. Move the main chute (Figure 29, Item 2) to the desired position, and while holding the chute, move the lever to the center. Make sure the lever pin is fully seated into one of the holes in the chute plate before releasing the chute. Move the chute from side to side as needed to align the pin and hole.

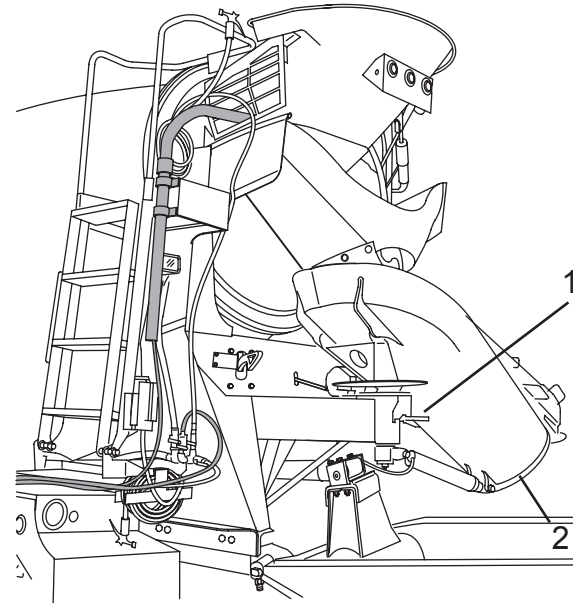



Figure 29

2.11 Fuse Functions

If a function in the cab pendant controls or rear pendant controls does not operate, check the condition of the fuses located in the cover of the control fuse box (in the cab control pendant) or the rear of the control box (cab control box). A label is located beside the fuses to identify the functions they control. If a fuse is blown, its indicator light will be flashing on the Power Distribution Module Splash screen on the touch screen (Figure 30).

 CAUTION
<p>Do not replace a fuse with a higher amperage fuse than is listed for the location. Always use new fuses of the correct amperage.</p> <p>Using a fuse with a higher amperage may cause damage to the equipment.</p>

Fuse No.	Amperage Rating	Description
F1	20 amps	Body Function 1 Power
F2	15 amps	Body Function 2 Power
F3	10 amps	Perimeter Lights Power
F4	25 amps	Fan Power

Fuse No.	Amperage Rating	Description
F5	10 amps	Strobe Lights Power
F6	5 amps	Sensor Power
F7	10 amps	Cab/HMI Power
F8	10 amps	Work Lights Power
F9	10 amps	Optional Power
F10	10 amps	Optional Power
F11	10 amps	Optional Power
F12	10 amps	Chute Power
F13	10 amps	Optional Power
F14	10 amps	Optional Power
F15	10 amps	Optional Power
F16	15 amps	Main Control Module Power

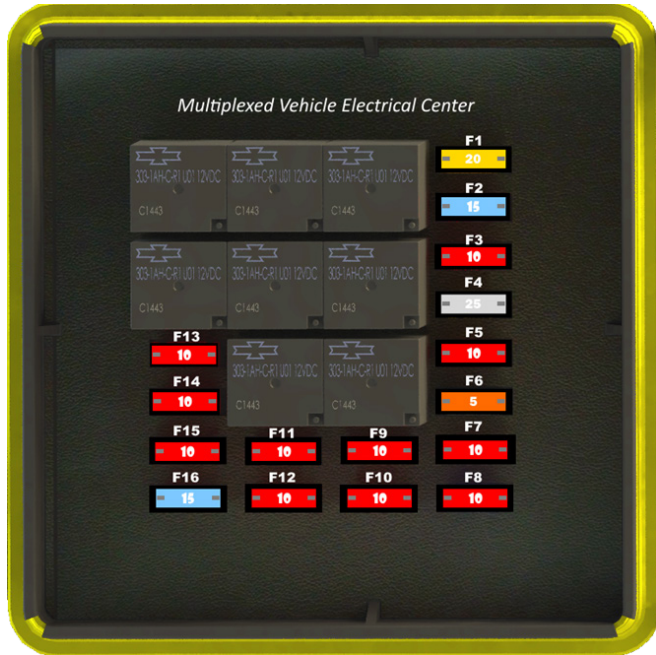

Figure 30

2.12 Manual Drum Operation

2.12.1 Manual Override - CHARGE and DISCHARGE

If the mixer cable control fails, and there is still a need to rotate the drum, the control cable can be disconnected to allow the pump drum drive to be engaged manually. This will allow the Mixer to be unloaded.

To engage the drum drive:

1. Pull back and hold the head (Figure 31, Item 1) of the control cable, and lift the end of the cable off the pivot (Figure 31, Item 2) to disconnect the control cable from the pump control lever (Figure 31, Item 3).
2. Move the pump control lever (Figure 31, Item 3) as required to start the drum rotation in the charge or discharge direction.
3. If the drum controls are still disabled after unloading, see Manual Override - Locking for Transit to configure the drum drive for transit.

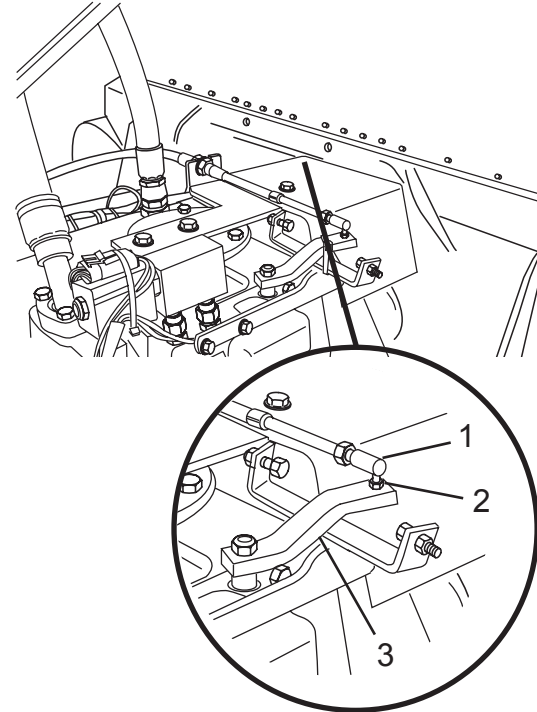

Figure 31

3.0 Control Functions for INSIGHT System Start-Up Function

After the chassis engine is started, drum control by the CHARGE and DRUM START/STOP buttons will not be allowed until the DRUM START/STOP light and CONSTANT SPEED light (Figure 32, Item 1) are OFF.

Select initial mode of drum operation (optional in-cab control keypad, joystick if equipped, or rear pendant keypad). If no mode is selected, the default mode is cab keypad.

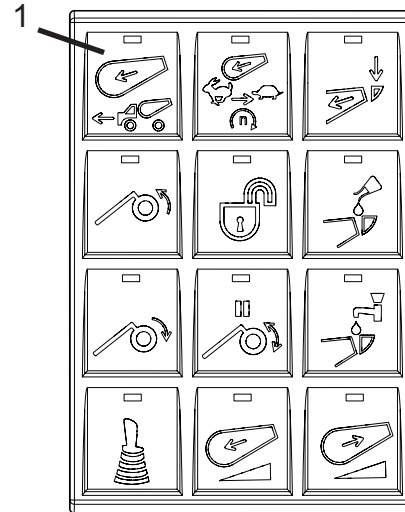

Figure 32

3.1 Rotating the Drum from the Joystick, Optional In-Cab Keypad, or Rear Pendant Keypad

The drum can be set to rotate by either the joystick, in-cab keypad, or the rear pendant keypad.

- If the joystick mode is activated, move the joystick in the desired direction for drum rotation.
- If in-cab keypad or rear keypad pendant is selected, keep pressing the CHARGE (forward) (Figure 33, Item 1) or DISCHARGE button (backward) (Figure 33, Item 2) until the desired rotation speed is achieved. You may also press and hold the charge or discharge keypad buttons until desired rotation speed is achieved. The key indicators will illuminate only when pressed.

Monitor drum speed on the home screen of the touch screen monitor and adjust as necessary. The display will show the speed of and direction of (charge or discharge) drum.

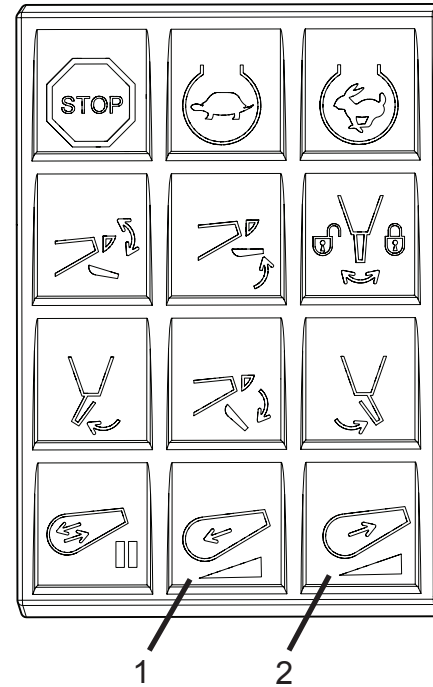

Figure 33

Operation

3.2 Rotating the Drum with the Wireless Transmitter (If Equipped)

1. Ensure the Constant Speed button indicator is not showing on the touch screen display.
 2. Ensure the drum start/stop indicator is turned OFF on the touch screen display.
- To turn OFF Drum Stop Indicator on the Wireless Transmitter, push the drum start/stop button as required (Figure 34).

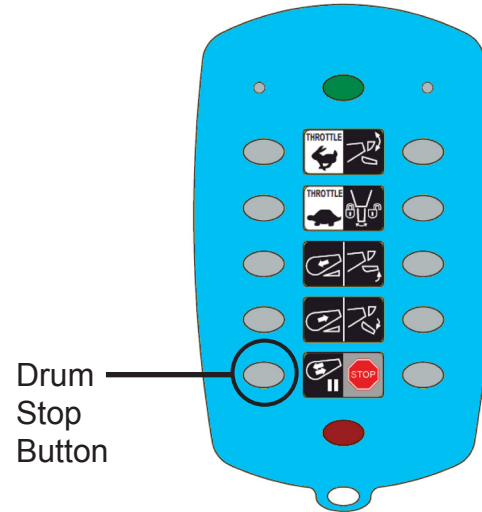

Figure 34

3. Press the appropriate button, either Charge or Discharge (Figure 35), on the Wireless Transmitter.
 - Drum Charge: Push to speed up drum while charging or to slow drum while discharging
 - Drum Discharge: Push to speed up drum while discharging or to slow drum while charging

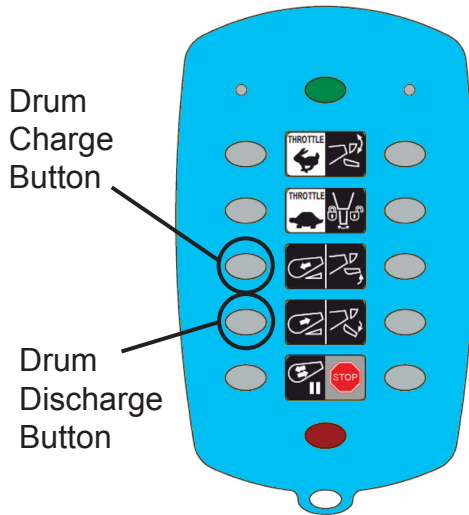

Figure 35

3.3 Drum Stop Operation

The following procedures are to stop the drum rotation using the standard in-cab keypad or the rear pendant keypad (Figure 36, Item 1), or Wireless Transmitter (Figure 37, Item 1).

1. The Drum STOP button must be off (light is off) upon truck start-up for drum rotation. The drum will stop immediately.
2. While drum is turning in either direction, press the STOP control button at any control station. The indicator light will illuminate red and the drum will stop.
3. To resume drum operation, push STOP button. The indicator light will go out and the drum will re-start in the same direction and speed prior to the STOP event.

Operation

Standard In-Cab Keypad

Rear Pendant Keypad

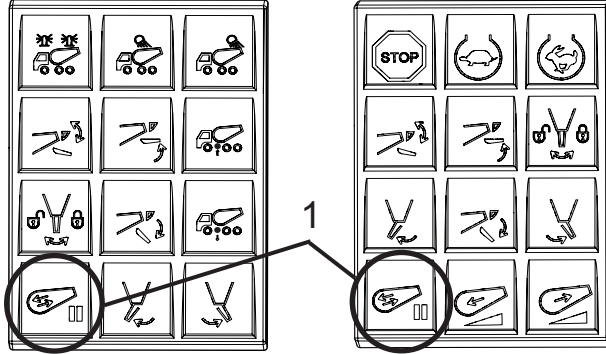

Figure 36

Wireless Transmitter

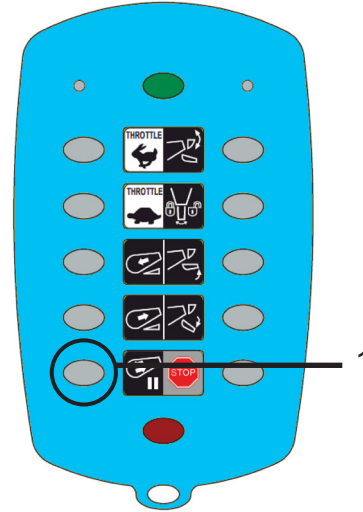

Figure 37

3.4 Load Function (If Equipped - Electronic Drum Controls Only)

The Load function button is located on the optional in-cab control keypad only. The load function of the controls allows one-touch operation of the loading function. When the button is pressed, the engine RPM will go the full preset and the drum speed will accelerate to 18 RPM or to maximum drum speed based on rear engine PTO ratio and maximum engine RPM.

1. Pull or back the Mixer into the plant's load lane.
2. Position the charge hopper directly under the discharge chute at the batch plant.
3. Truck must be in Park/Neutral, parking brake must be set to active, and Cruise Control Switch turned on.
4. Press the LOAD button on the optional in-cab keypad (Figure 38, Item 1). The button indicator will illuminate. The LOAD icon will display on the drum control on the touch screen monitor.
5. The truck's engine will ramp to full RPM preset and the drum will accelerate to 18 RPM in the charge direction.
6. When loading is complete, press the LOAD button or push the brake pedal or Constant Speed button.

The system will default to the Constant Speed preset (the Constant Speed button indicator will illuminate).

7. If manual drum control is desired, press the CONSTANT SPEED button (its indicator light will go out) and select the DRUM CONTROL mode.

Optional In-Cab Keypad

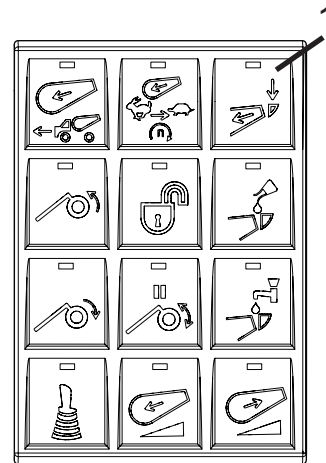

Figure 38

Operation

3.5 Mix Function (If Equipped - Electronic Drum Controls Only)

The Mix function button is located on the optional in-cab keypad only. The MIX function of the controls allows for one-touch operation of mixing function prior to job pour. When pressed, the engine RPM will go to the full preset and the drum speed will accelerate to preset Mix RPM for a preset number of drum revolutions.

1. Truck must be in Park/Neutral, parking brake must be set to active, and Cruise Control Switch turned on.
2. Press the MIX button on the optional in-cab keypad (Figure 39, Item 1). The button indicator will illuminate. The MIX icon will display on the drum control on the touch screen monitor.
3. The truck engine will ramp to full RPM preset and the drum will accelerate to MIX RPM in the charge direction ONLY for a preset number of revolutions.
4. When mixing revolutions reach the preset, MIX mode will cancel engine and the drum will slow to IDLE and CONSTANT SPEED respectively. The system will then default to Constant Speed preset (the Constant Speed button indicator will illuminate).
5. If manual drum control is desired, press the CONSTANT SPEED button (its indicator light will go out) and select the DRUM CONTROL mode.

Optional In-Cab Keypad

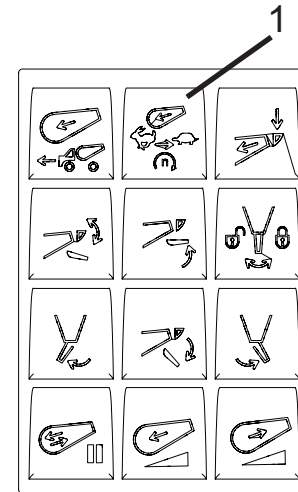

Figure 39

3.6 Constant Speed Function (Electronic Drum Controls Only)

The Constant Speed function maintains a constant pre-programmed speed (preset value between 1 and 3 RPM) in the charge direction for all engine RPM. The CONSTANT SPEED function button is located on the optional in-cab keypad only. The CONSTANT SPEED function of the controls allows for one-touch operation of a preset slow charge drum speed for transport to the job site without the need to manually adjust the controls.

NOTE: Constant Speed will automatically engage when either the LOAD or MIX modes are cancelled or shut off and/or when the vehicle speed reaches a preset threshold.

1. To manually engage CONSTANT SPEED mode, press the CONSTANT SPEED button on the optional in-cab keypad (Figure 40, Item 1). The button indicator will illuminate when mode is selected. All other mixer drum inputs are disabled while this mode is activated.

NOTE: All other mixer drum inputs and rear throttle controls are disabled while this mode is activated.

2. To turn off, press the CONSTANT SPEED button again.

NOTE: Drum will return to RPM that was active prior to turning on Constant Speed mode.

Optional In-Cab Keypad

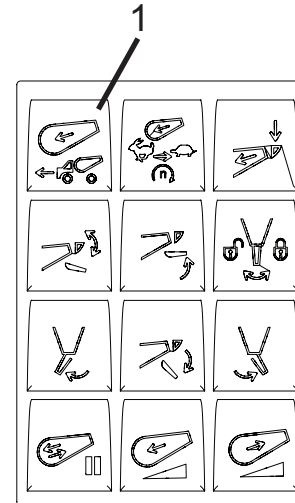

Figure 40

NOTE

If the drum Charge or Discharge function is activated, the Constant Speed Function will be activated immediately after pressing the Constant Speed switch.

If the drum Charge or Discharge function is NOT activated, the START/STOP switch must be pressed to activate the Constant Speed function.

When the Constant Speed Function is activated, the CHARGE and DISCHARGE switches are disabled on the cab and rear pendant controls.

3.7 Hopper Function

The Hopper function button is located on the standard in-cab keypad or the rear pendant keypad only. To activate the Hopper function, press the HOPPER function button on either the standard in-cab keypad or the rear pendant (Figure 41, Item 1).

NOTE: The Hopper UP or DOWN icons will display on the touch screen monitor.

The button indicator will illuminate when mode is selected. Indicator light is red when hopper is up and green when hopper is down.

OPERATIONAL NOTE: Upon truck startup, cycle the Hopper button until the “Hopper DOWN” icon is illuminated on the touch screen monitor.

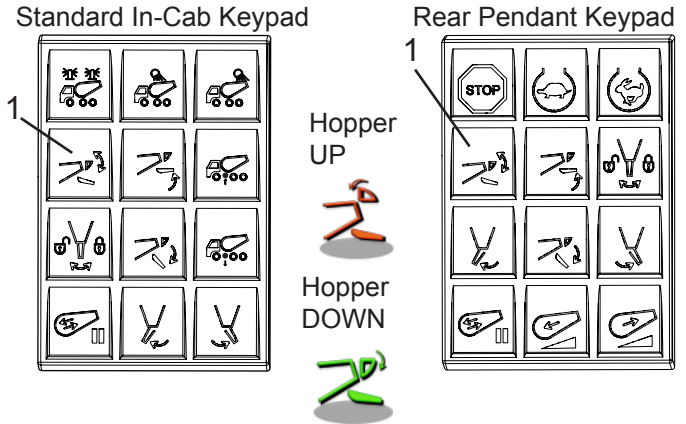

Figure 41

3.8 Chute Lock Function

The Chute Lock function button is located on the standard in-cab keypad. To activate the Chute Lock function, press the CHUTE LOCK function button on either the standard in-cab keypad or the rear pendant (Figure 42, Item 1).

NOTE: The Chute Lock Unlocked or Locked icons will display on the touch screen monitor.

The button indicator will illuminate when mode is selected. Indicator light is red when unlocked and green when locked.

OPERATIONAL NOTE: Upon truck startup, cycle the Chute LOCK button until the “Chute LOCK” icon is illuminated on the touch screen.

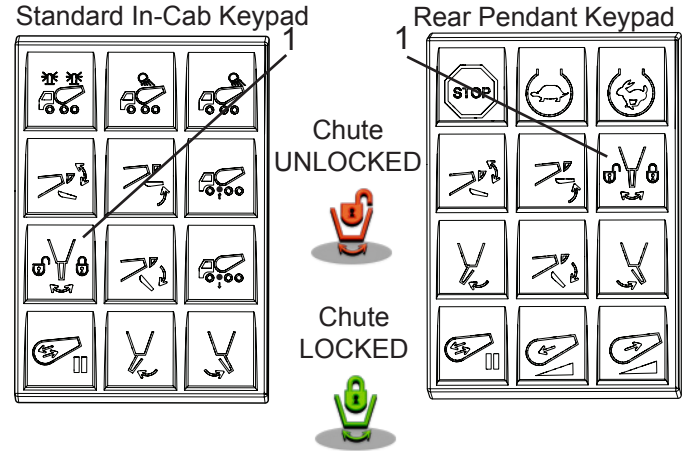

Figure 42

Operation

3.9 Chute Raise/Lower and Swing Functions

The Chute Raise/Lower function buttons and the Swing (left or right) function buttons are located on the standard in-cab keypad and on the rear pendant keypad only (Chute Swing is an optional feature). To activate the Chute Raise/Lower or Swing functions, press the appropriate function buttons on either the standard in-cab keypad or the rear pendant keypad (Figure 43). Press and hold the desired function button until desired movement is achieved.

Indicator lights will illuminate green only when pressed.

Ref.	Function
1	Chute UP
2	Chute DOWN
3	Chute Swing LEFT
4	Chute Swing RIGHT

Standard In-Cab Keypad

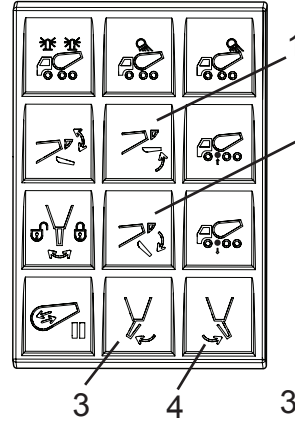

Rear Pendant Keypad

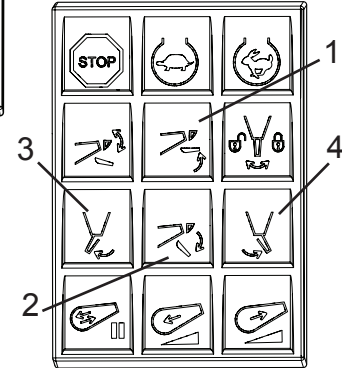

Figure 43

3.10 Hopper, Chute Lock, and Chute Operation with Wireless Transmitter (If Equipped)

Hopper Operation: Push the Hopper button to raise/lower air hopper (option) (Figure 44, Item 1).

Chute Lock: Push the Chute Lock button to lock/unlock air chute lock (Figure 44, Item 2).

Chute Raise Operation: Push the Chute Raise button to raise chute (Figure 44, Item 3).

Chute Lower Operation: Push the Chute Lower button to lower chute (Figure 44, Item 4).

OPERATIONAL NOTE: Upon truck startup, cycle the Hopper button and the Chute LOCK button until “Hopper DOWN” and “Chute LOCK” icons are illuminated on the touch screen.

OMNEX Wireless Transmitter

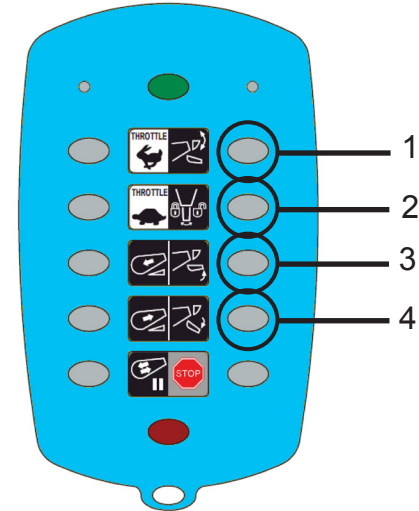

Figure 44

Operation

3.11 Work Lighting Functions

The standard in-cab keypad (Figure 45) is the only method for enabling or disabling the work lighting functions. The touch screen monitor only displays whether the work lighting is turned on or off.

- Press the keypad button to turn on or off the Strobe Lights, Perimeter Lights, and Work Lights.

Ref.	Function	Description
1	Strobe Lights	All locations of strobe lights.
2	Perimeter Lights	Fender mounted perimeter lights.
3	Work Lights	Rear pedestal work lights.

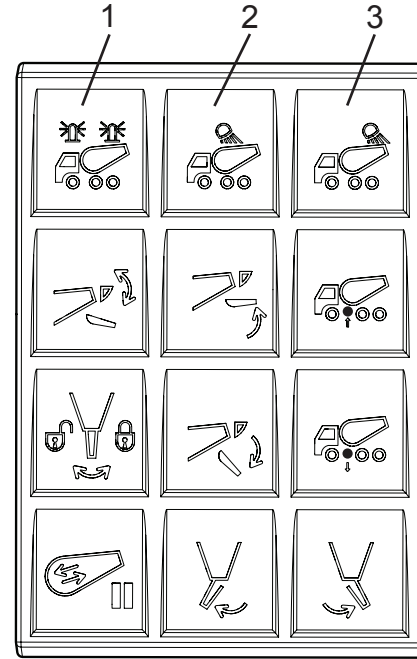

Figure 45

4.0 Traditional Electronic Control System Instruments and Controls

If your Mixer is equipped with electronic controls (not touch screen controls), the following figures and tables identify and describe the electronic controls. These instructions include optional features that may or may not be included on your Mixer.

To make sure you understand proper operating procedures, read this section and carefully practice with the controls and instruments to learn how to safely operate the equipment.

4.1 EP Drum Control System

4.1.1 Maestro Revision E-10

Several enhancements were made to the EP Drum Control System with the implementation of Revision E-10 to the Maestro.

Some of the new enhancements are as follows:

- The Charge and Discharge inputs are disabled when the CONSTANT SPEED switch is ON
- Remains in Constant Speed mode after the CONSTANT SPEED switch is turned OFF until any of the START/STOP, CHARGE OR DISCHARGE switches are pressed

- A dual ramp rate is utilized that enables a faster ramping rate to be used after the CHARGE or DISCHARGE switch is pressed and held for more than 1 second
- Drum speed is limited to 18 RPM
- A 50 Hz dither signal is incorporated to enhance response

4.1.2 How to Identify Revision E-10

An electronic module (Maestro) is located in the control fuse box. Maestros that are programmed with the enhancements of Revision E-10 can be identified by a label on the Maestro. The label will include the identifier number, followed by a letter that reflects the revision level (in this case revision “B”) (Figure 46, Item 1). The Revolution part number 1109192 (Figure 46, Item 2), for the Maestro with Revision E-10 programming, is also identified.

Operation

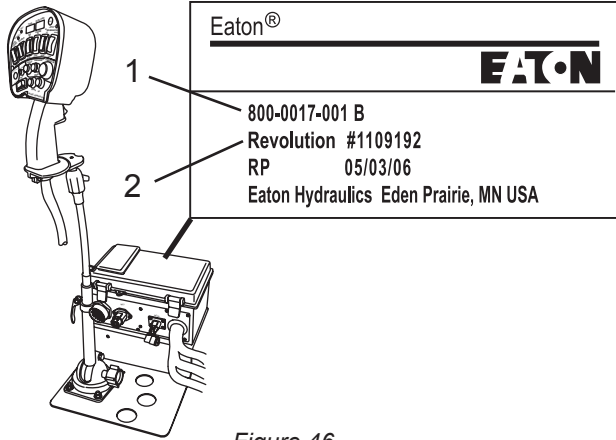

Figure 46

4.2 Electronic Cab Controls - Cab Control Pendant

The in-cab controls consist of a control pendant (Figure 47, Item 1), a control fuse panel (Figure 47, Item 2) in a fuse box (Figure 47, Item 3), and a jumper plug (Figure 47, Item 4).

No.	Item	Description
1	Control Pendant	Controls Drum, Chute, and Accessory Functions. Contains various indicator lights and displays.
2	Fuse Panel	Contains fuses for the mixer function electrical circuits.
3	Control Fuse Box	Contains fuses for the mixer function electrical circuits. The Control Fuse Box also includes a connector and jumper that are used to place the Mixer in the TRANSPORT or NORMAL operation modes.
4	Jumper Plug	The jumper plug is used to place the Mixer in either the TRANSPORT or NORMAL operation modes.

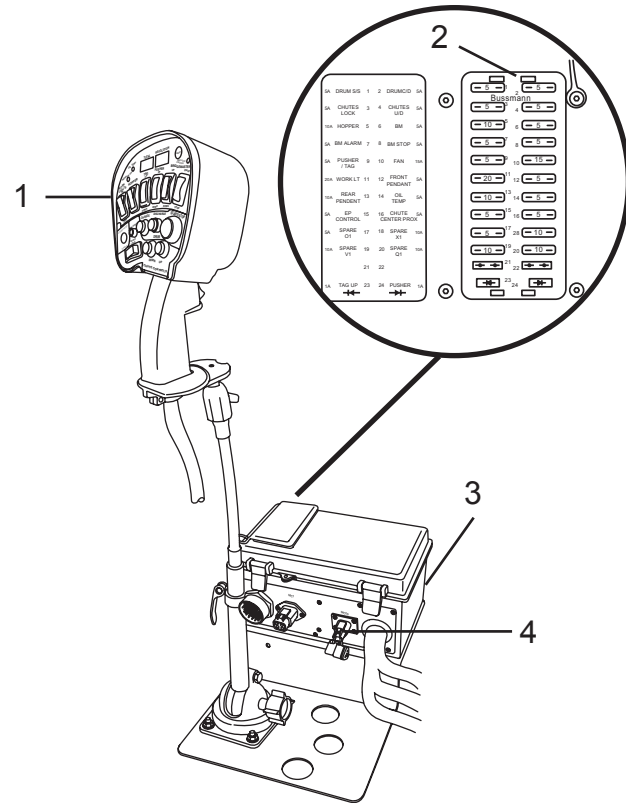

Figure 47

Operation

4.2.1 Electronic Cab Control Rocker Switch Functions

Accessories and mixer functions and some options are operated by switches on the control pendant (Figure 48 and Figure 49). The actual switches present on the control pendant will vary, depending on the configuration of your Mixer.

No.	Item	Operation
1	WATER Rocker Switch	Press the switch to inject water into the mixer drum. (See Remote Water Injection System for more information.)
2	CHUTE SWING Rocker Switch	Press the top of the switch to move the discharge chute to the right. Press the bottom of the switch to move the discharge chute to the left.
3	PUSHER Rocker Switch (OPTIONAL)	Select DOWN to lower the pusher axle(s). 1 Select UP to raise the pusher axle(s).

No.	Item	Operation
4	DISCHARGE Switch	Activates drum rotation in discharge (CCW) direction. Also increases drum speed in discharge (CCW) direction or decreases drum speed in charge (CW) direction.
5	BRIDGEMASTER UP/DOWN Rocker Switch 2	Not Applicable.
6	BRIDGEMASTER START/STOP Rocker Switch	Not Applicable.
7	START/STOP Switch	Press the switch to start and stop drum functions.
8	CHUTE UP Switch	Press and hold the switch to raise the discharge chute.
9	CHUTE DOWN Switch	Press and hold the switch to lower the discharge chute.

No.	Item	Operation
10	CHARGE Switch	Activates drum rotation in charge (CW) direction. Also increases drum speed in charge (CW) direction or decreases drum speed in discharge (CCW) direction.
11	CHUTE LOCK Rocker Switch	Press the switch to engage the chute air lock function. 2
12	CONSTANT SPEED Switch	Activates drum rotation at a constant speed in the charge (CW) direction.
13	WORK LIGHTS Rocker Switch	Select ON to activate the work lights. Select OFF to deactivate the work lights.
14	HOPPER Rocker Switch	Press the switch to swing the air flip-up charge hopper up or down. 2
15	BRIDGEMASTER ACTIVATE Switch	Not Applicable.

¹ The pusher axle(s) will automatically raise when the truck is placed in reverse. (See Pusher Axles.)

² The function triggered by the switch will depend on the current state of that device. (Example: If the charge hopper is up, activating the switch will lower it.)

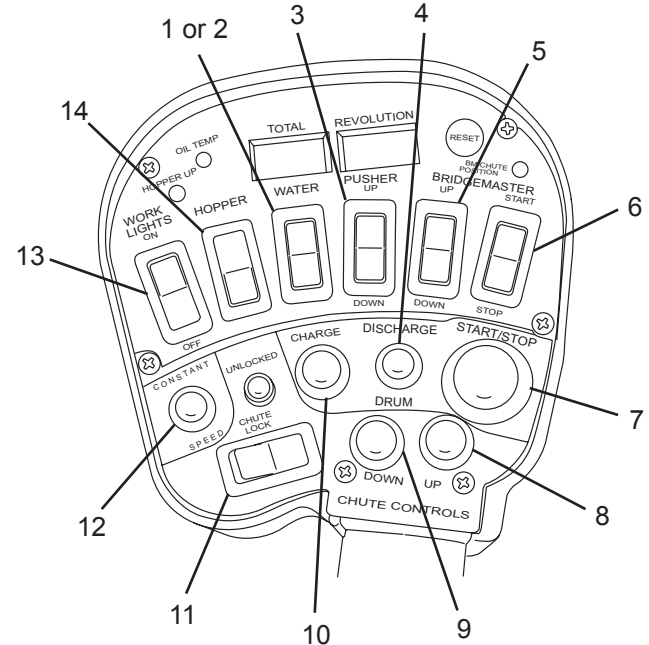

Figure 48

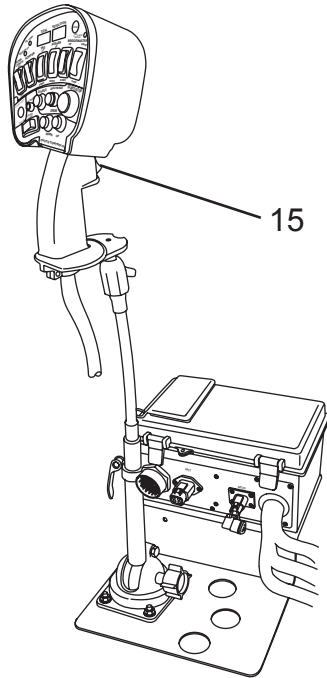

Figure 49

4.2.2 Indicator Light and Display Functions

The indicator lights and displays (Figure 50) are used to display the status of various functions. The actual indicator lights present on the control pendant will vary, depending on the configuration of your Mixer.

No.	Item	Operation
1	HOPPER UP Indicator Light	Light indicates when the charge hopper is in the raised position.
2	OIL TEMP Indicator Light	Light indicates when the hydraulic oil reaches 215°F (102°C).
3	TOTAL Display	Indicates the total number of drum revolutions. Counter cannot be reset.
4	REVOLUTION Counter Display	Indicates the number of drum revolutions. Counter can be reset.
5	RESET Button	Press to reset the REVOLUTION counter display.
6	BM/CHUTE POSITION Indicator Light	Not Applicable.

No.	Item	Operation
7	DISCHARGE Indicator Light	Indicates when the drum is rotating in the discharge direction. Also used for fault code diagnostics.
8	CHUTE LOCK Indicator Light (OPTIONAL)	Indicates when the main chute air lock is unlocked.
9	CONSTANT SPEED Indicator Light (OPTIONAL)	Indicates when the CONSTANT SPEED function is enabled.

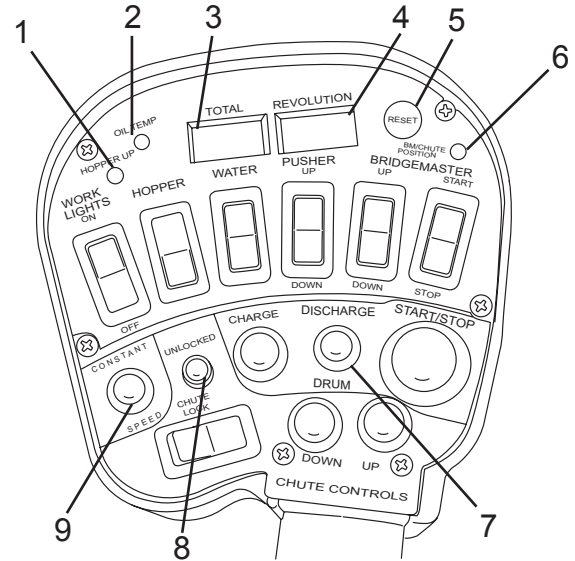

Figure 50

Operation

4.3 Electronic Cab Controls - Cab Control Box

The control box (Figure 51) contains rocker switches, displays for the various mixer functions, lights, and options. The control box also contains a fuse panel.

No.	Item	Description
1	Control Box	Controls drum, chute, and accessory functions. Contains various indicator lights and displays.
2	Fuse Panel	Contains fuses for the mixer function electrical circuits.

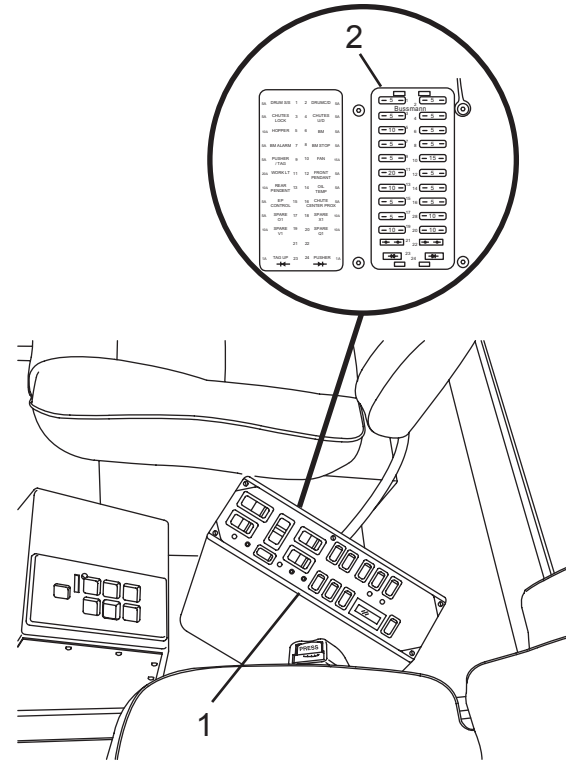

Figure 51

4.3.1 Electronic Cab Control Rocker Switch Functions

Accessories and mixer functions and some options are operated by rocker switches on the top of the control box (Figure 52). The actual switches present in the control box will vary depending on the configuration of your Mixer.

No.	Control	Normal Use or Reading
1	DRUM CHARGE/ DISCHARGE Rocker Switch	<p>Press the CHARGE side of the switch to activate the drum rotation in CHARGE (CW) direction. Holding the switch down also increases drum speed in CHARGE (CW) direction or decreases drum speed in DISCHARGE (CCW) direction.</p> <p>Press the DISCHARGE side of the switch to activate the drum rotation in DISCHARGE (CCW) direction. Holding the switch down also increases drum speed in DISCHARGE (CCW) direction or decreases drum speed in CHARGE (CW) direction.</p>

Operation

No.	Control	Normal Use or Reading
2	CHUTE UP/ DOWN Rocker Switch	Select UP to raise the discharge chute. Select DOWN to lower the discharge chute.
3	CHUTE SWING Rocker Switch (OPTIONAL)	Press and hold the right side of the switch to move the chute to the right. Press and hold the left side of the switch to move the chute to the left.
4	PUSHER Rocker Switch (OPTIONAL)	Select DOWN to lower the pusher axle(s). Select UP to raise the pusher axle(s). ¹
5	BRIDGEMASTER ACTIVATE Rocker Switch	Not Applicable.
6	BRIDGEMASTER UP/DOWN Rocker Switch	Not Applicable.
7	BRIDGEMASTER START/STOP Rocker Switch	Not Applicable.

No.	Control	Normal Use or Reading
8	ADD WATER Rocker Switch (OPTIONAL)	Press the switch to inject water into the mixer drum. (See Remote Water Injection System.)
9	WORK LIGHT Rocker Switch (OPTIONAL)	Select ON to activate the work lights. Select OFF to deactivate the work lights.
10	HOPPER Rocker Switch (OPTIONAL)	Press the switch to swing the air flip-up hopper up or down. ²
11	CHUTE LOCK Rocker Switch (OPTIONAL)	Press the right side of the switch to engage or disengage the chute air lock.
12	CONSTANT SPEED Rocker Switch (OPTIONAL)	Press the right side of the switch to activate drum rotation at a constant speed in the charge direction (CW). Press the left side of the switch to deactivate the constant speed function.

No.	Control	Normal Use or Reading
13	DRUM S/S (Start/Stop) Rocker Switch (OPTIONAL)	Press the switch to start or stop drum functions. ¹

¹ The pusher axle(s) will automatically raise when the truck is placed in reverse. (See Pusher Axles.)

² The function triggered by the switch will depend on the current state of that function. (Example: If the charge hopper is up, activating the switch will lower it.)

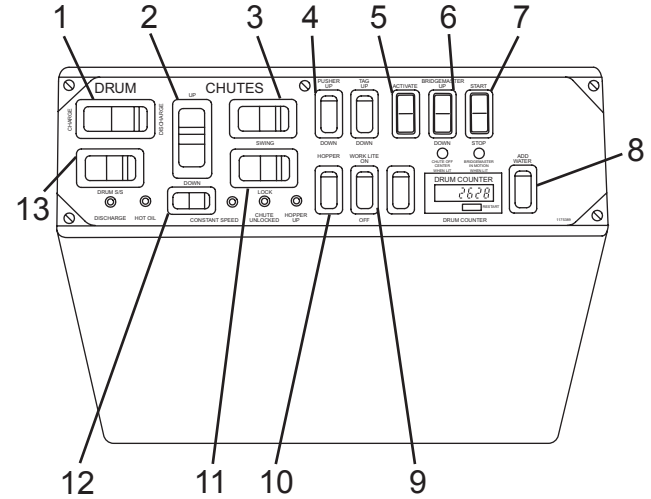

Figure 52

Operation

4.3.2 Indicator Light and Display Functions

The indicator lights and displays (Figure 53) are used to display the status of various functions. The actual indicator lights present in the control box will vary depending on the configuration of your Mixer.

No.	Item	Normal Use or Reading
1	CHUTE OFF CENTER when lighted	Light indicates when the discharge chute is off the center position.
2	BRIDGEMASTER IN MOTION when lighted	Not Applicable.
3	DRUM COUNTER Display	Counts the number of revolutions of the mixer drum in either direction. Push the button to reset.
4	HOPPER UP Indicator Light (OPTIONAL)	Light indicates when the charge hopper is in the raised position.
5	CHUTE UNLOCKED Indicator Light (OPTIONAL)	Light indicates when the discharge chute is unlocked.

No.	Item	Normal Use or Reading
6	CONSTANT SPEED Indicator Light (OPTIONAL)	Indicates when the CONSTANT SPEED function is enabled.
7	HOT OIL Indicator Light (OPTIONAL)	Light indicates when the hydraulic oil reaches 215°F (102°C).
8	DISCHARGE Indicator Light (OPTIONAL)	Indicates when the drum is rotating in the DISCHARGE direction. Also used for fault code diagnostics.

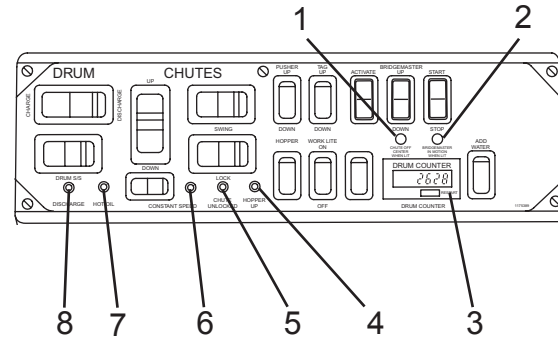

Figure 53

4.4 Electronic Outside Controls

The outside controls consist of a rear pendant (Figure 54, Item 1) and a manual chute lock (Figure 54, Item 2).

No.	Item	Description
1	Rear Control Pendant	Contains toggle switches to control various mixer functions. The controls contained will vary depending on options.
2	Manual Chute Lock	Mechanically locks the discharge chute in one of several positions.

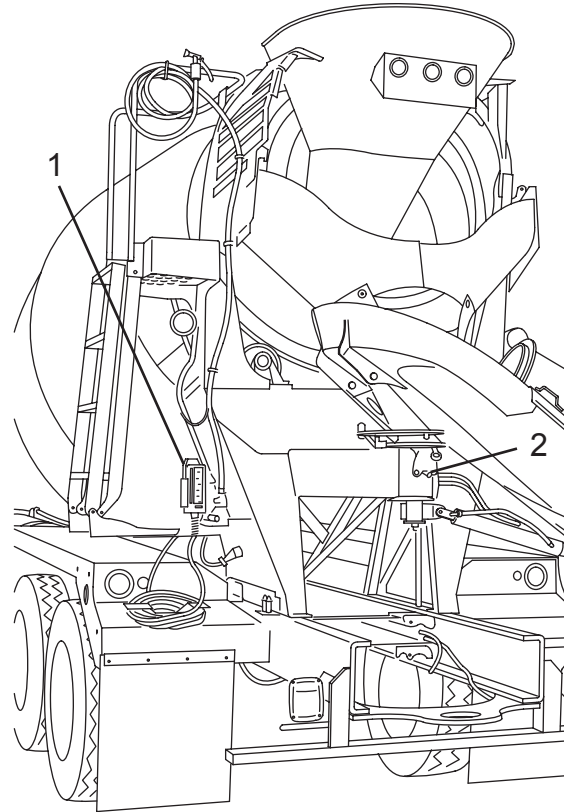

Figure 54

Operation

4.4.1 Electronic Rear Pendant Controls

The rear pendant (Figure 55) toggles switches to control various mixer functions. The actual switches present in the rear pendant will vary depending on the configuration of your Mixer. The operator can take the rear pendant up the ladder platform for quick access to starting and stopping the drum.

No.	Control	Normal Use or Reading
1	THROTTLE Toggle Switch (OPTIONAL) 1	Push and hold the switch to the right to increase the engine speed. Push and hold the switch to the left to decrease the engine speed. (See Adjusting the Throttle Speed.)
2	HOPPER Toggle Switch (OPTIONAL)	Push the switch to move the hopper up or down. 2 If the pendant is equipped with the chute swing option, the HOPPER switch will be moved from the pendant to the rear pedestal.

No.	Control	Normal Use or Reading
3	CHUTE SWING Toggle Switch (OPTIONAL)	Push the switch to the right to swing the chute to the right. Push the switch to the left to swing the chute to the left.
4	CHUTE LOCK Toggle Switch (OPTIONAL)	Push the switch to activate or deactivate the discharge chute air lock. 2
5	CHUTE UP/ DOWN Toggle Switch	Push and hold the switch to the right to raise the discharge chute. Push and hold the switch to the left to lower the discharge chute.
6	DRUM CHARGE/ DISCHARGE Toggle Switch (OPTIONAL)	Activates drum rotation in charge (CW) and discharge (CCW) directions. Also increases and decreases drum speed in charge and discharge directions.
7	DRUM S/S Toggle Switch (OPTIONAL)	Starts and stops drum functions. 2

¹ The chassis cruise control must be in the ON position, the parking brake must be applied, and the automatic transmission must be in NEUTRAL.

² The function triggered by the switch will depend on the current state of that function. (Example: If the charge hopper is up, activating the switch will lower it.)

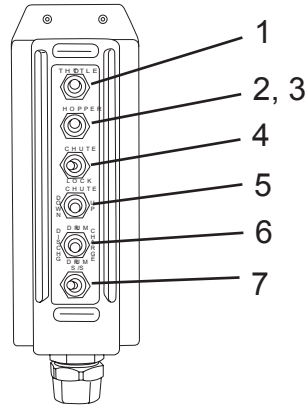

Figure 55

2. Disconnect the rear pendant harness connector (Figure 56, Item 2) from the rear pedestal.
3. Install a jumper plug (Figure 56, Item 3) into the rear pendant harness connector. Purchase the jumper plug from www.streetSMARTparts.com or by calling Revolution Parts at (855) 202-6491.
4. Start the truck.
5. Operate the mixer functions using the cab control box.

4.4.1.1 By-Passing the Rear Pendant

If the rear pendant (Figure 56, Item 1) is lost, or becomes damaged or faulty, a jumper plug (Figure 56, Item 3) must be installed in the rear pendant socket to allow operation of control functions from the cab control box.

Contact Revolution Parts and Support at (855) 202-6491 for jumper plug part numbers.

1. Turn truck ignition switch OFF. (Refer to the Operator's Manual supplied by the chassis supplier for all shut-down and parking procedures.)

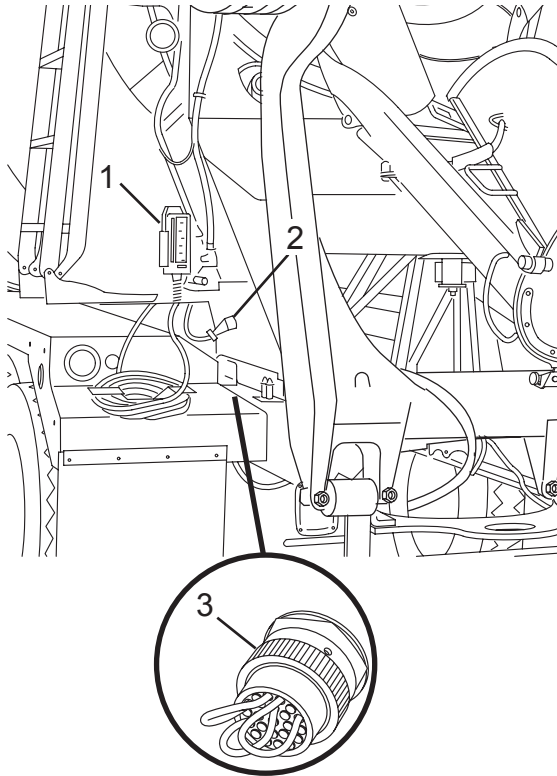

Figure 56

4.4.2 Manual Chute Lock

⚠ CAUTION

Do not move the vehicle without locking the chute with the manual chute lock. Do not use the chute air lock to secure the chute for transport. Failure to comply may cause damage to property or equipment.

The manual chute lock mechanically locks the chute in one of several pre-determined positions.

To move the chute:

1. Unlock the chute air lock (if equipped).
2. While holding the chute, pull down on the lever (Figure 57, Item 1) and move it to the right or left until the lever is seated in one of the lock positions.
3. Move the main chute (Figure 57, Item 2) to the desired position, and while holding the chute, move the lever to the center. Make sure the lever pin is fully seated into one of the holes in the chute plate before releasing the chute. Move the main chute from side to side as needed to align the pin and hole.

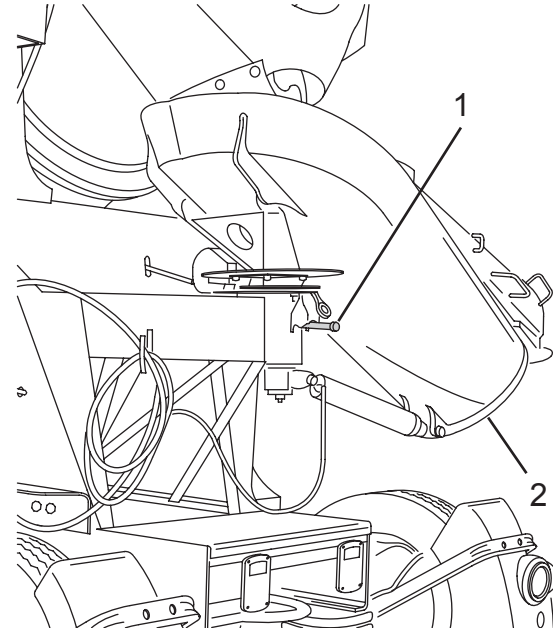

Figure 57

Operation

4.5 Fuse Functions

If a function in the electronic cab pendant controls or rear pendant controls does not operate, check the condition of the fuses (Figure 58) located in the cover of the control fuse box (in the cab control pendant) or the rear of the control box (cab control box). A label is located beside the fuses to identify the functions they control.

CAUTION

Do not replace a fuse with a higher amperage fuse than is listed for the location. Always use new fuses of the correct amperage. Failure to comply may cause damage to property or equipment.

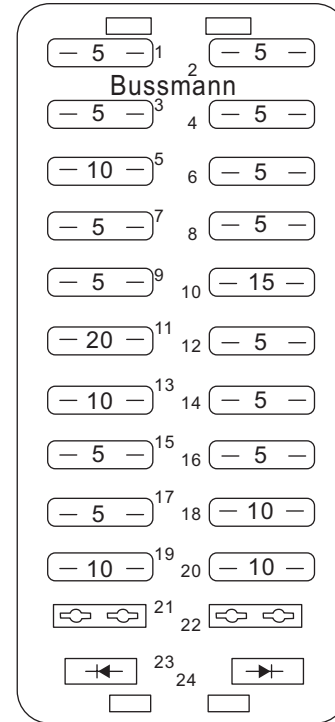

Figure 58

Fuse No.	Amperage Rating	Description
1	5 amp	DRUM S/S (Start/Stop) (OPTIONAL)
2	5 amp	DRUM C/D (Charge/ Discharge)
3	5 amp	CHUTE LOCK (OPTIONAL)
4	5 amp	CHUTE U/D (Up/Down)
5	10 amp	HOPPER (OPTIONAL)
6	5 amp	BM - Not Applicable
7	5 amp	BM ALARM - Not Applicable
8	5 amp	BM STOP - Not Applicable
9	5 amp	PUSHER/TAG (OPTIONAL)
10	15 amp	FAN
11	20 amp	WORK LT (OPTIONAL)
12	5 amp	FRONT PENDANT (Cab Control Box)
13	10 amp	REAR PENDANT
14	5 amp	OIL TEMP
15	5 amp	Not Used
16	5 amp	Not Used

Fuse No.	Amperage Rating	Description
17	5 amp	Spare Power 01
18	10 amp	Spare Power X1
19	10 amp	Spare Power V1
20	10 amp	Spare Power Q1
21	N/A	Not Used
22	N/A	Not Used
23	N/A	Tag Up Diode
24	N/A	Pusher Up Diode

5.0 Traditional Cable Control System Instruments and Controls

The following figures and tables identify and describe the cable controls. These instructions include optional features that may or may not be included on your Mixer.

To make sure you understand proper operating procedures, read this section and carefully practice with the controls and instruments to learn how to safely operate the equipment.

5.1 Cable Cab Controls

The in-cab controls are located on the mixer console between the seats (Figure 59).

The control box contains rocker switches, displays for the various mixer functions, lights, and options. The control box also contains a fuse panel.

No.	Position	Normal Use or Reading
3	Drum Control Lever (CHARGE/DISCHARGE)	Contains the drum rotation direction and speed.

No.	Position	Normal Use or Reading
1	Fuse Panel	Contains fuses for the mixer function electrical circuits.
2	Control Box	Controls drum, chute, and accessory Functions. Contains various indicator lights and displays.

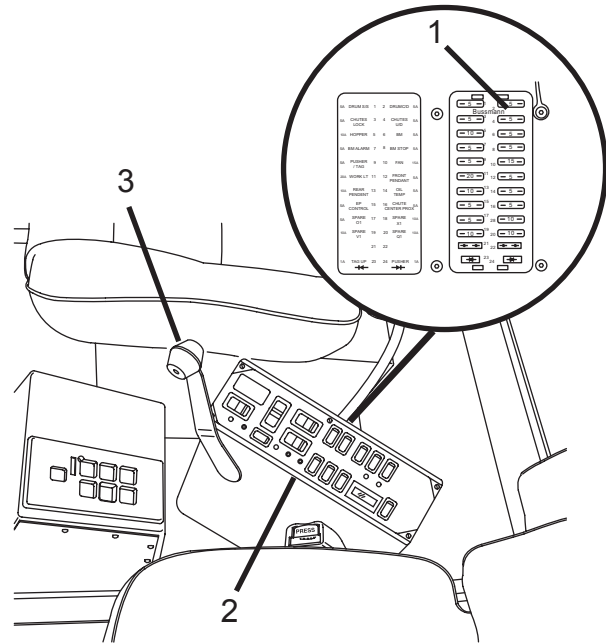

Figure 59

5.1.1 Cable Cab Control Rocker Switch Functions

Accessories and mixer functions and some options are operated by rocker switches on the top of the control box (Figure 60). The actual switches present in the control box will vary, depending on the configuration of your Mixer.

No.	Item	Description
1	DRUM S/S (Start/Stop) Rocker Switch (OPTIONAL)	Press the switch to start or stop drum functions. ¹
2	CHUTE UP/ DOWN Rocker Switch	Select UP to raise the main chute. Select DOWN to lower the main chute.
3	CHUTE SWING Rocker Switch (OPTIONAL)	Press and hold the right side of the switch to move the chute to the right. Press and hold the left side of the switch to move the chute to the left.
4	PUSHER Rocker Switch (OPTIONAL)	Select DOWN to lower the pusher axle(s). Select UP to raise the pusher axle(s). ²

No.	Item	Description
5	TAG Rocker Switch (OPTIONAL)	Select DOWN to lower the tag axle. Select UP to raise the tag axle.
6	ADD WATER Rocker Switch	Press and hold switch to inject water into the mixer drum. (See “Remote Water Injection System” for further information.) If the Mixer is equipped with the ADD WATER option, the ADD WATER rocker switch will be placed in one of the vacant switch positions.
7	WORK LIGHT Rocker Switch (OPTIONAL)	Select ON to activate the work lights. Select OFF to deactivate the work lights.
8	HOPPER Rocker Switch (OPTIONAL)	Press the switch to swing the air flip-up hopper up or down. ¹
9	CHUTE LOCK Rocker Switch (OPTIONAL)	Press the switch to engage or disengage the chute air lock. ¹

Operation

¹ The function triggered by the switch will depend on the current state of that device. (Example: If the charge hopper is up, activating the switch will lower it.)

² The tag and pusher axle(s) will automatically raise when the truck is placed in reverse. (See "Auxiliary Tag and Pusher Axle Operation.")

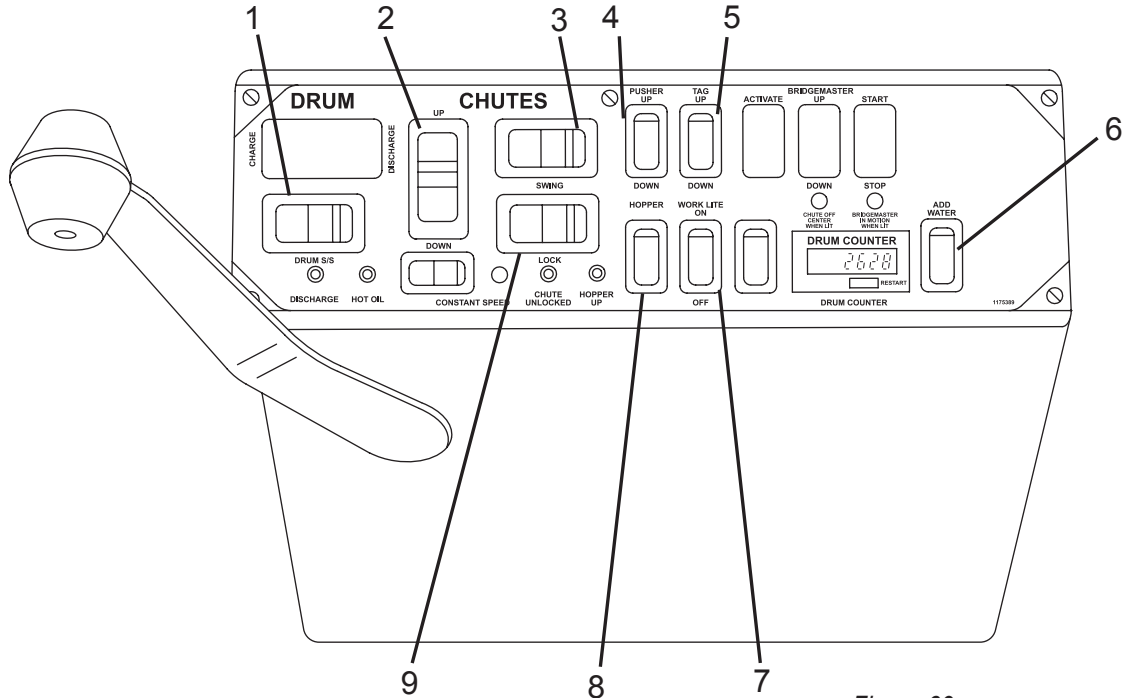

Figure 60

5.1.2 Indicator Light and Display Functions

The indicator lights and displays (Figure 61) are used to display the status of various functions. The actual indicator lights present in the control box will vary, depending on the configuration of your Mixer.

No.	Item	Operation
1	HOT OIL TEMP Indicator Light	Light indicates when the hydraulic oil reaches 215°F (102°C).
2	DRUM COUNTER Display	Counts the number of revolutions of the mixer drum in either direction. Push the counter to reset.
3	HOPPER UP Indicator Light (OPTIONAL)	Light indicates when flip-up charge hopper is in the raised position.
4	CHUTE UNLOCKED Indicator Light (OPTIONAL)	Indicates when the main chute air lock is unlocked.

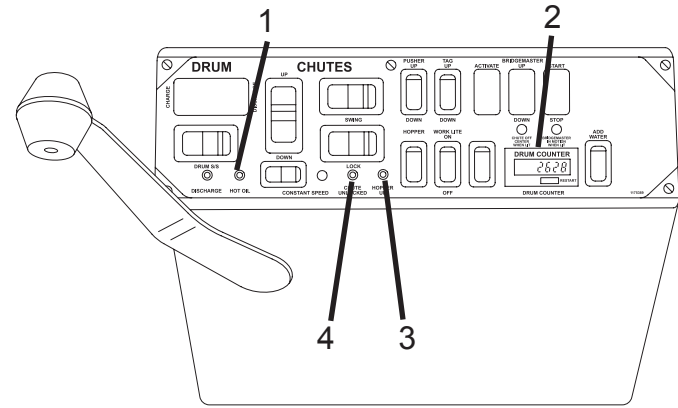

Figure 61

Operation

5.2 Cable Outside Controls

The outside controls consist of an optional rear pendant, drum cable control, and a manual chute lock (Figure 62).

No.	Item	Description
1	Rear Control Pendant (If Equipped)	Contains toggle switches to control various mixer functions. The controls contained will vary, depending on options.
2	Drum Control	Contains the drum control lever that controls the speed and direction of the drum rotation. Early models may also contain toggle switches to control various mixer functions. The controls contained will vary, depending on options.
3	Manual Chute Lock	Mechanically locks the main chute in one of several positions.

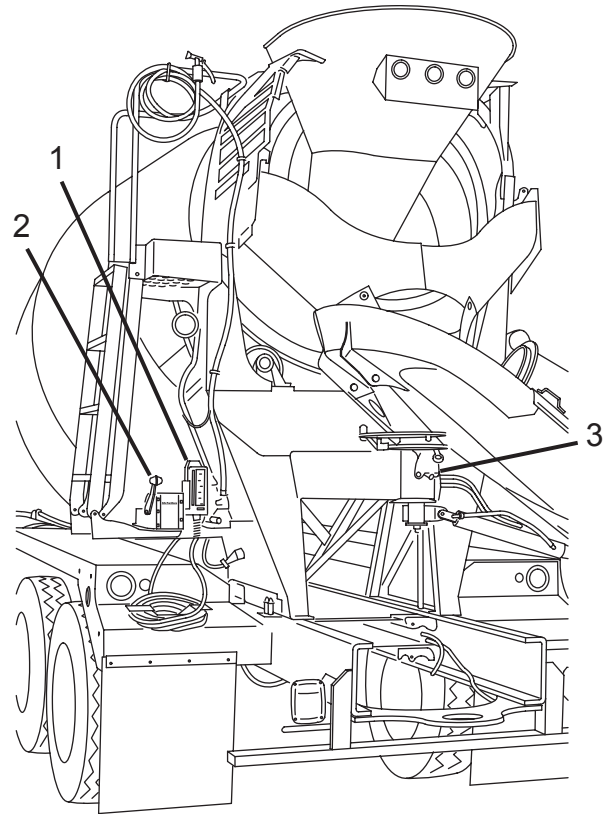

Figure 62

5.2.1 Cable Rear Pendant Controls

The rear pendant (Figure 63) contains toggle switches to control various mixer functions. The actual switches present in the rear pendant will vary, depending on the configuration of your Mixer.

No.	Control	Normal Use or Reading
1	THROTTLE Toggle Switch (OPTIONAL)	Push and hold the switch to the right to increase the engine speed. ¹ Push and hold the switch to the left to decrease the engine speed. (See “Adjusting the Throttle Speed” for more information.)
2	HOPPER Toggle Switch (OPTIONAL)	Push the switch to move the flip-up charge hopper up or down. ²
3	CHUTE LOCK Toggle Switch (OPTIONAL)	Push the switch to activate or deactivate the main chute air lock. ²

No.	Control	Normal Use or Reading
4	CHUTE UP/DOWN Toggle Switch	Push and hold the switch to the right to raise the main chute. Push and hold the switch to the left to lower the main chute.
5	CHUTE SWING Toggle Switch (OPTIONAL)	Push the switch to the right to swing the chute to the right. Push the switch to the left to swing the chute to the left.
6	DRUM S/S (START/STOP) Toggle Switch (OPTIONAL)	Push the switch to start or stop drum functions. ²

¹ The chassis cruise control must be in the ON position, the parking brake must be applied, and the automatic transmission must be in NEUTRAL.

² The function triggered by the switch will depend on the current state of that function. (Example: If the charge hopper is up, activating the switch will lower it.)

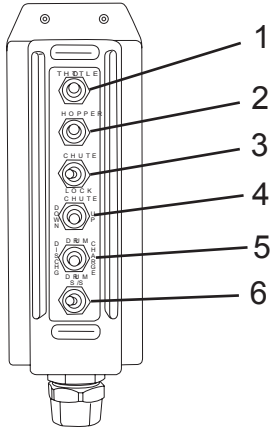

Figure 63

5.2.1.1 By-Passing the Rear Pendant

If the optional rear pendant (Figure 64, Item 1) is lost, or becomes damaged or faulty, a jumper plug (Figure 64, Item 3) must be installed in the rear pendant socket to allow operation of control functions from the cab control box.

Contact Revolution Parts and Support at (855) 202-6491 for jumper plug part numbers.

1. Turn truck ignition switch OFF. (Refer to the Operator's Manual supplied by the chassis supplier for all shut-down and parking procedures.)
2. Disconnect the rear pendant harness connector (Figure 64, Item 2) from the rear pedestal.
3. Install a jumper plug (Figure 64, Item 3) into the rear pendant harness connector. Purchase the jumper plug from www.streetsmartparts.com or by calling Revolution Parts at (855) 202-6491.
4. Start the truck.
5. Operate the mixer functions using the cab control box.

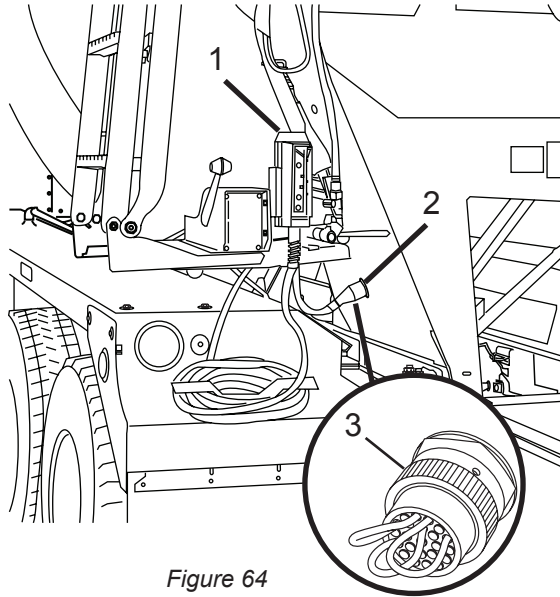

Figure 64

5.2.2 Cable Drum Control

The drum control (Figure 65) contains the drum control lever and toggle switches that control various mixer functions.

If equipped with a rear pendant, the function switches will be located there.

No.	Control	Normal Use or Reading
1	Drum Control Lever (CHARGE/DISCHARGE)	<p>Starting at the NEUTRAL position, pushing the lever forward (away from the operator) starts the drum rotating in the CHARGE direction. The farther the lever is pushed forward, the faster the drum rotates.</p> <p>Pulling the lever back (toward the operator), will decrease the drum speed until the NEUTRAL position is reached, at which time the drum stops rotating.</p> <p>From the NEUTRAL position, pulling the lever back (toward the operator), the drum starts rotating in the DISCHARGE direction. The farther the lever is pulled back, the faster the drum rotates.</p>
2	HOPPER Toggle Switch (OPTIONAL)	Push the switch to move the flip-up charge hopper up or down. ¹

Operation

No.	Control	Normal Use or Reading
3	CHUTE LOCK Toggle Switch (OPTIONAL)	Push the switch to activate or deactivate the discharge chute air lock. ¹
4	THROTTLE Toggle Switch (OPTIONAL)	Push to increase or decrease throttle speed. ² (See “Adjusting the Throttle Speed”.)
5	DRUM S/S (START/STOP) Toggle Switch (OPTIONAL)	Push the switch to start or stop drum functions. ¹
6	CHUTE UP/DOWN Toggle Switch	Push and hold the switch to the right to raise the main chute. Push and hold the switch to the left to lower the main chute.

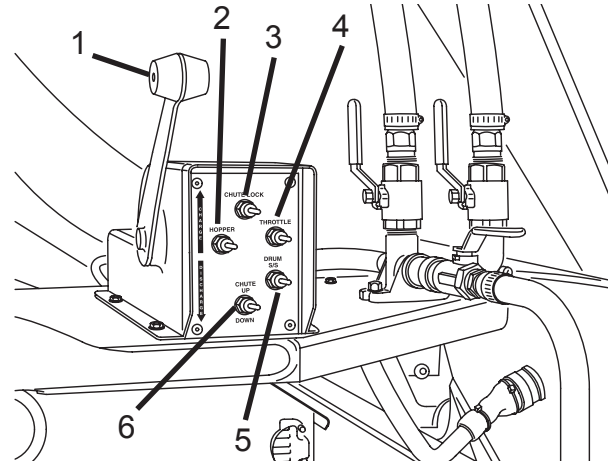

Figure 65

¹ The function triggered by the switch will depend on the current state of that device. (Example: If the charge hopper is up, activating the switch will lower it.)

² The chassis cruise control must be in the ON position, the park brake must be applied, and the automatic transmission must be in NEUTRAL.

5.2.3 Manual Chute Lock

⚠ CAUTION

Do not move the vehicle without locking the chute with the manual chute lock. Do not use the chute air lock to secure the chute for transport. Failure to comply may cause damage to property or equipment.

The manual chute lock mechanically locks the chute in one of several pre-determined positions.

To move the chute:

1. Unlock the chute air lock (if equipped).
2. While holding the chute, pull down on the lever (Figure 66, Item 1) and move it to the right or left until the lever is seated in one of the lock positions.
3. Move the main chute (Figure 66, Item 2) to the desired position, and while holding the chute, move the lever to the center. Make sure the lever pin is fully seated into one of the holes in the chute plate before releasing the chute. Move the main chute from side to side as needed to align the pin and hole.

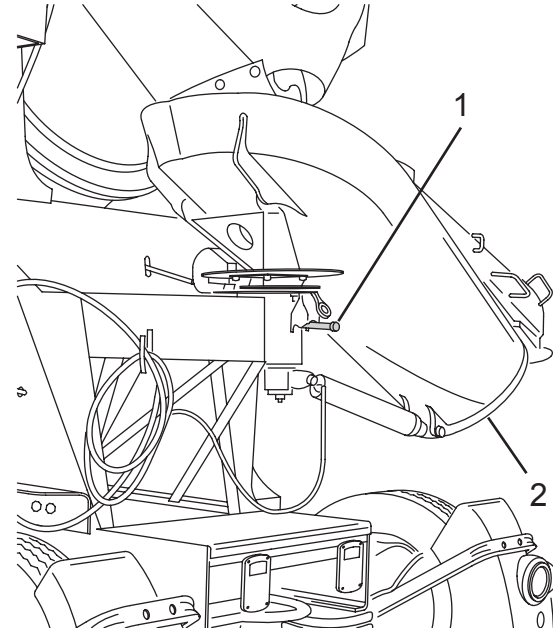

Figure 66

5.3 Fuse Functions

If a function in the cable cab pendant controls or rear pendant controls does not operate, check the condition of the fuses (Figure 67) located in the cover of the control fuse box (in the cab control pendant) or the rear of the control box (cab control box). A label is located beside the fuses to identify the functions they control.

CAUTION

Do not replace a fuse with a higher amperage fuse than is listed for the location. Always use new fuses of the correct amperage. Failure to comply may cause damage to property or equipment.

Fuse No.	Amperage Rating	Description
1	5 amp	DRUM S/S (Start/Stop) (OPTIONAL)
2	5 amp	DRUM C/D (Charge/Discharge)
3	5 amp	CHUTE LOCK (OPTIONAL)
4	5 amp	CHUTE U/D (Up/Down)
5	10 amp	HOPPER (OPTIONAL)
6	5 amp	Not Used

Fuse No.	Amperage Rating	Description
7	5 amp	Not Used
8	5 amp	Not Used
9	5 amp	PUSHER/TAG (OPTIONAL)
10	15 amp	FAN
11	20 amp	WORK LT (OPTIONAL)
12	5 amp	FRONT PENDANT (Cab Control Box)
13	10 amp	REAR PENDANT
14	5 amp	OIL TEMP
15	5 amp	Not Used
16	5 amp	Not Used
17	5 amp	Spare Power O1
18	10 amp	Spare Power X1
19	10 amp	Spare Power V1
20	10 amp	Spare Power Q1
21	N/A	Not Used
22	N/A	Not Used
23	N/A	Tag Up Diode
24	N/A	Pusher Up Diode

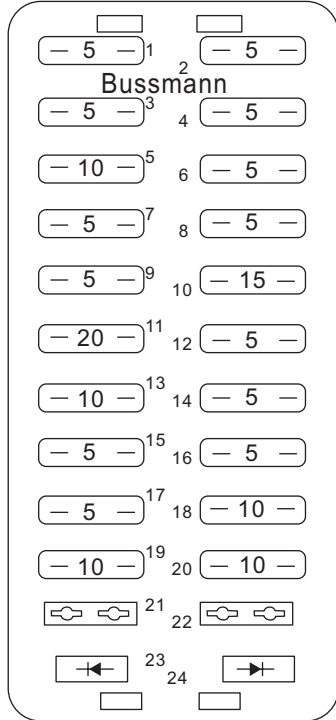

Figure 67

5.4 Manual Drum Operation

5.4.1 Manual Override - CHARGE and DISCHARGE

NOTE

The manual pump override is intended for emergency use only. When engaged, the drum will be driven at a speed determined by the amount the lever is moved. Pump location will vary, depending on truck configuration. Front-mounted pump shown.

If the mixer cable control fails, and there is still a need to rotate the drum, the control cable can be disconnected to allow the pump drive drum to be engaged manually. This will allow the mixer to be unloaded.

To engage the drum drive:

1. Pull back and hold the head (Figure 68, Item 1) of the control cable. Lift the end of the cable off the pivot (Figure 68, Item 3) to disconnect the control cable from the pump control lever (Figure 68, Item 2).
2. Move the pump control lever (Figure 68, Item 2) as required to start the drum rotation in the charge or discharge direction.

3. If the drum controls are still disabled after unloading, see “Manual Override - Locking for Transit” to configure the drum drive for transit.

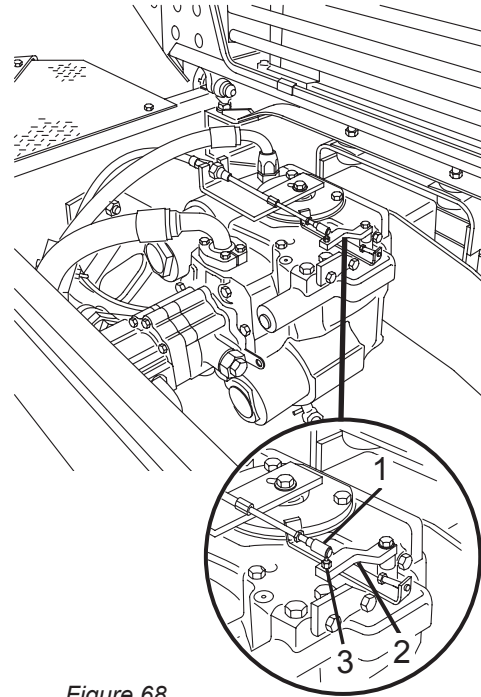

Figure 68

5.4.2 Manual Override - Locking for Transit

 **CAUTION**

Always rotate drum when truck is in motion. Never stop the drum while driving. Failure to comply may cause damage to property or equipment.

NOTE

Use manual pump overrides for emergency use only.

If the mixer cable control fails, and there is still a need to rotate the drum, the control cable can be disconnected to allow the pump drive drum to be engaged manually. This will allow the truck to be driven to the shop for repair with the drum rotating.

To manually override the mixer controls:

1. Move the pump control lever (Figure 69, Item 2) to engage the drum drive in the CHARGE direction. Move the lever until the drum is rotating at approximately 1 to 1-1/2 RPM in the CHARGE direction.

2. Secure the lever using a tie strap, wire, or similar item to make sure the drum continues to rotate at the proper speed while in transit to the repair shop.
3. Once the truck is delivered to the repair shop and properly parked, return the pump control lever to the neutral position, and connect the control cable (Figure 69, Item 4) to the pump control lever (Figure 69, Item 2), by pulling back the head (Figure 69, Item 1) of the cable and installing the cable over the pivot (Figure 69, Item 3). Release the cable head (Figure 69, Item 1).
4. Remove the Mixer from service until repairs are completed.
5. Call Revolution Mixers Support at (855) 202-6491 if you have questions or need help.

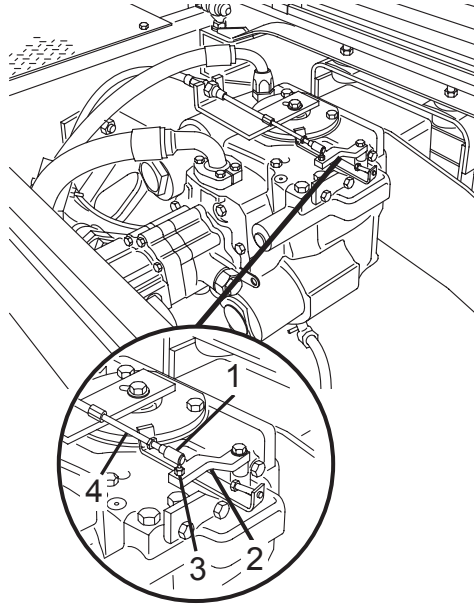

Figure 69

5.5 Add Water Function (If Equipped)

5.5.1 Manual Water Injection System

Water can be added to the drum by opening the water injection ball valve (Figure 70, Item 1) located at the rear of the Mixer.

Some Mixers may be equipped with an optional valve (Figure 70, Item 3). This valve will automatically close when the handle is released.

WARNING

Never allow the water from the tank to drain onto a public sidewalk or roadway. Water may cause the sidewalk or roadway to become slippery. Always drain the water system at a location designated by the job site manager or in compliance with your company policy. Failure to comply may result in serious personal injury or death.

Both valves may be equipped with a drain option. This feature automatically drains the water from the hose(s) beyond the valve, through a small hole at the rear of the valve (Figure 70, Item 2).

5.5.2 Remote Water Injection System for Traditional Control System

This system allows the operator to add water while remaining in the cab by activating the ADD WATER switch on the cab control box. (See “Rocker Switch Functions” for more information.)

To add water:

1. Open the water injection ball valve (Figure 71, Item 1).

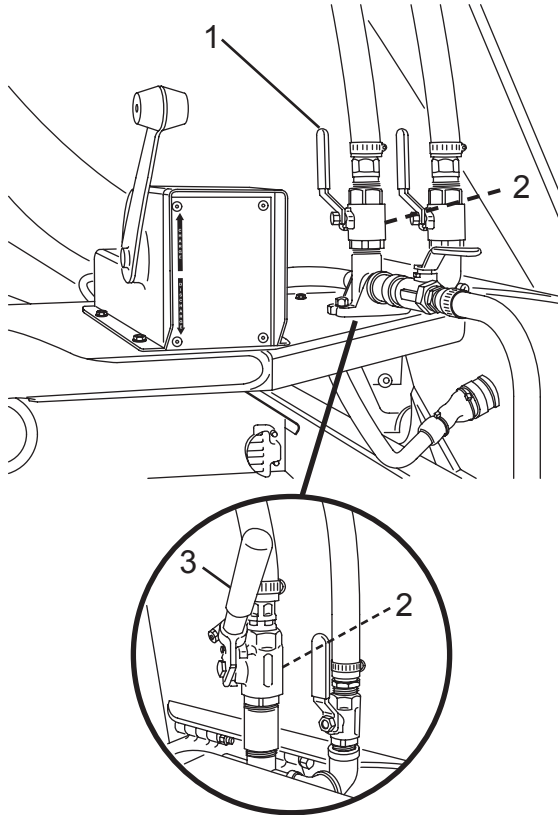

Figure 70

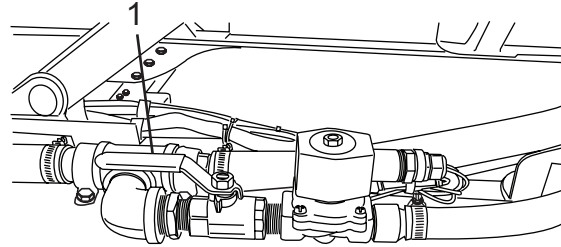

Figure 71

2. Press and hold the ADD WATER rocker switch on the cab control box to activate the system. (See “Rocker Switch Functions” for more information.)
3. Release the rocker switch when the desired amount of water has been added. (If equipped with a water meter, see “Water Meter Function”.)
4. Close the water injection ball valve (Figure 71, Item 1).

6.0 Operating Procedures

6.1 Start-Up Procedure

NOTE

Perform pre-trip inspection of chassis and Mixer according to all federal, state, and local laws.

Before starting the vehicle, make certain that all daily checks have been completed and verified. (See PREVENTIVE MAINTENANCE INTERVALS.)

Perform a walk-around inspection to verify that all controls and components (main and fold-over chutes, chute extensions, hoses, etc.) are properly stored and secured.

6.2 Warm-Up Procedure

At start-up of the equipment each morning, it is important to cycle through each of the main hydraulic and air circuits to be certain each circuit is functioning properly. Cycling through each operation also helps ensure that the hydraulic fluid is up to operating temperature and is present throughout the system.

Cycle through each of the following operations:

1. Main Chute Functions – Cycle 3 times
2. Chute Air Lock Function (if equipped) – 1 time
3. Flip-Up Charge Hopper Function (if equipped) – 1 time

NOTE

Allow the hydraulic oil to warm to operating temperature before rotating the drum.

4. Drum Functions – Rotate in CHARGE and DISCHARGE direction for 5 minutes.

CAUTION

If you detect a problem with any control function, it must be repaired immediately. DO NOT operate the Mixer with malfunctioning controls. Failure to comply may cause damage to property or equipment.

After completing the cycle tests, inspect the Mixer for any hydraulic leaks. If leaks are detected, correct them BEFORE the Mixer is placed into operation.

6.3 Adjusting the Throttle Speed

When using the rear pendant control keypad to adjust the throttle speed, the procedures will vary, depending on the engine installed in the chassis. Check the chassis information supplied with the Mixer to determine which engine is installed in your truck.

NOTE

Depressing the chassis brake pedal will disengage the cruise control and cause the engine speed to return to idle. The cruise control must be engaged to throttle.

6.3.1 Paccar, Navistar, and Detroit Diesel Engines

1. Place the chassis cruise control in the ON position, apply the parking brake, and place the automatic transmission in NEUTRAL. Ensure the Drum STOP is OFF (drum must be turning) and Constant Speed is OFF. (Refer to the chassis information provided with the Mixer for further information.)

Throttle Up: Push and hold the THROTTLE ADVANCE button (on the rear pendant control keypad) until the desired speed is obtained, and release the button/switch. The THROTTLE ADVANCE button can also be pressed and released to advance the throttle speed in increments.

2. Throttle Down: Push and hold the THROTTLE RETARD button (on the rear pendant control keypad), until the desired speed is obtained, and release the button/switch. The THROTTLE RETARD button can also be pressed and released to reduce the throttle speed in increments.

6.3.2 Mack® Engines – Rear Pendant

To use the Rear Throttle Controls or the touch screen:

- Ensure the parking brake is set and the Mixer is in NEUTRAL
 - Drum STOP must be OFF (drum must be turning)
 - Constant Speed must be OFF
1. Press and release the Throttle Raise button (rabbit icon) to achieve maximum PTO speed.
 2. Press and release the Throttle Lower button (turtle icon) to achieve pouring PTO speed (normally 1200 RPM).
 3. To bring remote PTO speed back to idle, press and hold the Throttle Lower button (turtle icon).

Operation

6.3.3 Mack® Engines – Wireless Remote Control

To use the Wireless Transmitter:

- **Ensure the parking brake is set and the Mixer is in NEUTRAL**
 - Drum STOP must be OFF (drum must be turning)
 - Constant Speed must be OFF
1. Press and release the Throttle Raise button (rabbit icon) to achieve maximum PTO speed.
 2. Press and release the Throttle Lower button (turtle icon) to achieve pouring PTO speed (normally 1200 RPM).
 3. To bring remote PTO speed back to idle, press and hold the Throttle Lower button (turtle icon).

6.3.4 Cummins® Engines

- **Ensure the parking brake is set and the Mixer is in NEUTRAL**
 - Drum STOP must be OFF (drum must be turning)
 - Constant Speed must be OFF
1. Press and release the Throttle Raise button (rabbit icon) to achieve maximum PTO speed.
 2. Press and release the Throttle Lower button (turtle icon) to achieve pouring PTO speed (normally 1200 RPM).

3. To bring remote PTO speed back to idle, press and hold the Throttle Lower button (turtle icon).

6.4 Upper Ladder Platform Gate Bar Usage (Optional Equipment)

If equipped with the upper ladder platform gate bar, follow these instructions for proper usage of the bar.

1. To enter the platform, push the bar up and in to create enough room to step onto the platform.
2. Lower the bar to return it to its starting position when you are on the platform.
3. To exit the platform, push the bar up and pull it in and exit the platform.
4. Return the bar to its starting position.

6.5 Loading the Mixer Drum

There are three types of concrete mixes that may be loaded into the Mixer. Each type of concrete has different mixing requirements.

The three mix types are:

Truck Mixed Concrete: In truck mixed concrete, all of the ingredients are charged directly into the truck mixer. No plant mixing is involved. Some or all of the mixing water is usually introduced at the plant.

Shrink Mixed Concrete: Shrink mixed concrete is partially mixed in a plant mixer and the concrete is then loaded into a truck mixer. Mixing is completed in the truck mixer.

Central Mixed Concrete: Central mixed concrete is completely mixed in a plant mixer.

1. If equipped with a flip-up charge hopper, make sure the hopper is lowered.
2. Pull or back the Mixer into the plant's load lane.
3. Position the charge hopper directly under the discharge chute at the batch plant.
4. Set the engine speed to maximum governed RPM.
5. Place the drum control into fast charge. The optimum drum speed for loading will vary.

6. After loading is complete, check the concrete slump and add water as needed.
7. Set the drum control to the CHARGE direction at the lowest drum speed.
8. Fill the water tank(s). In cold weather, the water may be hot, so be extremely careful.
9. Rinse the charge hopper.
10. Pick up delivery ticket, and make sure the ticket matches the materials loaded in your truck.

NOTE

The mixer drum should be rotating in the CHARGE direction at all times when the drum is filled with concrete and not discharging.

NOTE

Proper mixing speed for the drum is 12 to 14 rpm. In general, a proper mix can be obtained with 70 revolutions (at maximum drum speed) of the mixer drum. This count begins when the Mixer is fully loaded and ends when the Mixer begins transport to the job site. During transport, the drum speed should be approximately 1-1/2 rpm.

CAUTION

Liquid nitrogen should be applied directly to the concrete mix. If liquid nitrogen comes in direct contact with the drum, it could lead to early drum component failure. Failure to comply may cause damage to property or equipment.

6.5.1 Working Around Concrete Pumps

Refer to the NRMCA's Mixer Truck Driver's Manual that is placed in the vehicle's cab for helpful information regarding working around concrete pumps. Contact the National Ready Mixed Concrete Association (NRMCA) or Revolution Concrete Mixers for a copy of the manual if required.

6.6 Traveling to the Job Site

Before beginning travel to the job site, be sure that the Mixer is properly prepared for travel. This means that:

1. Access ladder(s) are folded up and securely latched.
2. Rear control pendant is properly stowed and secured.
3. Chute and chute extensions are clean and free of concrete and debris.

4. Chute extensions are properly stowed and secured.
5. Wash-out hose(s) are properly stowed and secured.
6. Fold-over chute is folded over the main chute and is properly secured.
7. Main chute is positioned with the end of the chute pointing toward the curb, and is locked using the manual chute lock.

WARNING

High Pressure Fluid Hazard. Never drive the truck with the water tank pressurized. Failure to comply may result in serious personal injury or death.

8. Water tank(s) are filled and depressurized and the water system is purged.

CAUTION

Do not stop the drum while in transit. Driving the vehicle without the drum rotating may cause damage to the equipment.

9. Drum is rotating in the CHARGE direction (CW) and is set at the proper speed (approximately 1 to 1-1/2 RPM, slower for longer transport distances, higher for shorter transport distances).

6.7 Positioning the Truck for Discharge

Before pulling into the pour site (parking site for the truck when unloading concrete), be sure the site is properly prepared for the truck. This means that:

1. It will be necessary to inspect the proposed access route to the pour site and the pour location to make sure it is safe to proceed.
 - If any hazards are noted, an alternate route must be determined or, if possible, the hazards must be removed.

WARNING

At the job site, use the lowest transmission gear and proceed at low speed, 3 mph (4.8 km/h) maximum, to the discharge area. Failure to comply may result in serious personal injury or death.

2. Drive the Mixer slowly to the pour site, staying on the pre-determined route.

DANGER

Crush Hazard. Never back up without taking every precaution to be sure the rear is clear. Watch mirrors for activity. Never back up the Mixer unless and until you are completely sure it is safe. Use a spotter/observer and/or get out and check yourself to ensure it is safe to do so. Failure to comply will result in serious personal injury or death.

3. If it is necessary to back the truck to the pour site, use a spotter to guide you into the site. The spotter should be standing to the side in clear view of your mirrors. The area behind the truck must be free of any other people.

6.8 Chute Operation

6.8.1 Unfolding the Fold-Over Chute

WARNING

Crush Hazard. Do not let persons, other than the driver, handle the chutes, unfold the fold-over, and/or remove extension, or stow and secure the extensions for transit. Keep hands away from chute hardware where the chutes connect. Never stand in the path of the chute as it is being unfolded or while in use. Failure to comply may result in serious personal injury or death.

CAUTION

Do not move the vehicle with the fold-over chute extended and chute extensions installed. Failure to comply may cause damage to property or equipment.

NOTE

If the mixer is equipped with an optional hydraulic fold-over chute, see Hydraulic Fold-Over Chute for more information.

1. Position the main chute so that there is sufficient room behind the chute. Lock the main chute using the manual chute lock or the optional chute air lock.
2. Disconnect the retaining chain (Figure 72, Item 1) from the fold-over chute (Figure 72, Item 2).
3. Grasp the fold-over chute by the handles (Figure 72, Item 3), and pivot the fold-over chute down until it firmly engages the main chute.

6.8.2 Using Chute Extensions

Figure 72

WARNING

Do not over-load chute extensions. Maximum load capacity of 400 lbs. per chute extension. Failure to comply may result in serious personal injury or death.

WARNING

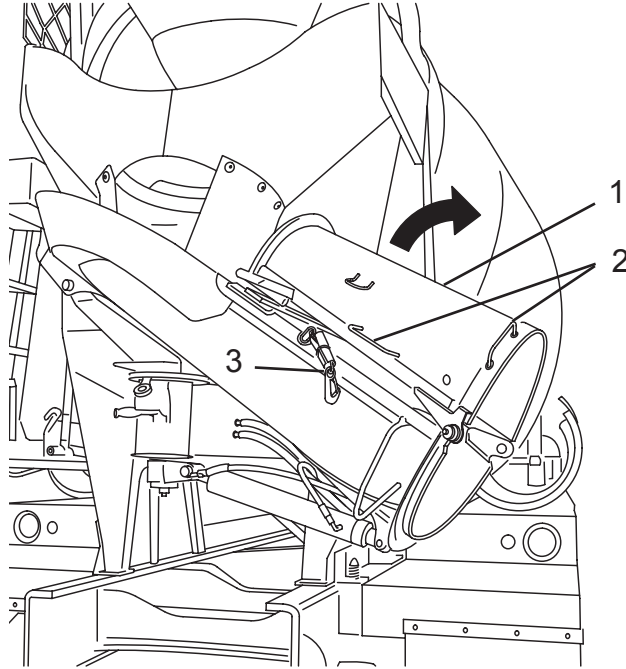
Inspect chute extensions prior to each use. Never use a damaged chute extension or a chute extension that has been driven over. Replace damaged chutes extensions immediately. Failure to comply may result in serious personal injury or death.

DANGER

Crush Hazard. Never stand on a chute or chute extensions. Do not use the chute as a crane to pull or transport objects. Failure to comply will result in serious personal injury or death.

CAUTION

Do not move the vehicle with the fold-over chute extended and chute extensions installed. Failure to comply may cause damage to property or equipment.

WARNING

Crush Hazard. Do not leave persons, other than the driver, handle the chutes, unfold the fold-over, and/or remove extension, or stow and secure the extensions for transit. Keep hands away from chute hardware where the chutes connect. Never stand in the path of the chute as it is being unfolded or while in use. Failure to comply may result in serious personal injury or death.

CAUTION

Crush Hazard. Do not use more chute extensions than are specified for your Mixer. Do not use any other type or style of chute extensions, other than ones designed for use with your Mixer. Failure to comply may cause damage to property or equipment.

1. Lock the main chute lock or optional chute air lock.
2. Unfold the fold-over chute.
3. Remove the number of chute extensions needed for the pour from chute storage.
4. Install the needed number of chute extensions on the fold-over chute. Never exceed three chute extensions.

6.8.3 Positioning the Discharge Chute Assembly

CAUTION

Do not move the vehicle with the fold-over chute extended and chute extensions installed. Failure to comply may cause damage to property or equipment.

1. Grasp the main chute handle and release the main chute lock using the manual chute lock or optional chute air lock.
2. Move the discharge chute to the desired location and lock the main chute with the manual chute lock or optional chute air lock.
3. Raise the main chute as needed using the CHUTE UP/DOWN switch on the rear pendant.

⚠ WARNING

Crush Hazard. When the chute lock is released, the chute may shift unexpectedly, especially if the truck is parked on an incline. Secure the chute before releasing the chute lock. Failure to comply may result in serious personal injury or death.

4. If it becomes necessary to move the chute while discharging:
 - a. Hold the chute securely.
 - b. Release the main chute lock using the manual chute lock or optional chute air lock.
 - c. Move the chute to the desired location.
 - d. Lock the chute using the manual chute lock or optional chute air lock.
5. If it becomes necessary to move the truck to a new location in order to continue discharging the load:
 - a. Stop discharging.
 - b. Remove the chute extensions.

NOTE

If moving the truck less than 15 feet (4.6 meters), the fold-over chute may be left extended.

- c. Fold the fold-over chute.
- d. Move the truck to the new location and install the chute extensions.

6.9 Discharging the Load

1. Park the truck safely. (Refer to the Operator's Manual supplied by the chassis supplier for all parking procedures.) The engine can remain at idle.
2. Unfold the fold-over chute and install chute extensions as needed.
3. Position the discharge chute assembly as needed.
4. If discharging low slump concrete, move the charge hopper away (if equipped with a flip-up or Swing Away Throat charge hopper).
5. To discharge, set the engine speed to 1100 to 1200 RPM, and set the drum control to DISCHARGE direction at the desired speed. A drum speed of 2 RPM will be sufficient for most work; however, greater or lesser speeds can be used, depending on the job conditions and type of concrete mix. A good

Operation

rule of thumb to follow is, the higher the slump of the concrete, the greater the allowable drum RPM; the lower the slump, the slower the drum should rotate for maximum discharge rate.

6. The main chute position is easily controlled by adjusting the chute height with the chute lifter and rotating the chute manually with the chute lifter and rotating the chute manually about its pivot point. A lock system is provided to lock the chutes and prevent rotation when leaving the purging position.
7. If it is necessary to add water to the concrete mix before discharging the load, activate the water injection system.

6.10 Wash Down the Mixer Before Leaving the Job Site



WARNING

The chassis transmission must be in neutral and the parking brake set before attempting to operate the mixer with external controls. Failure to comply may result in serious personal injury or death or extensive machine damage.

NOTE

The actual wash-down procedure may vary, depending on your company policies and procedures, and may or may not include all of the following steps.

NOTE

Do not discharge leftover concrete on the job site or anyway else, unless specifically instructed to do so by a company manager. Return leftover concrete to the plant for proper disposal.

1. Move the Mixer to the designated clean-out area.
2. Park the truck safely. (Refer to the Operator's Manual supplied by the chassis supplier for all parking procedures.)

NOTE

Never allow concrete wash water to enter a catch basin, creek, or storm drain, or flow onto the road or gutter. Never flush the drum out on the job site; this should be done only in the proper designated area at the plant yard. Improper discharge of wash water is illegal and can result in fines.

3. Set the mixer drum to rotate in the CHARGE position at no more than 4 RPM.

 WARNING

While washing down the mixer, use only those surfaces and areas designated for standing on to perform the procedure. Avoid surfaces of any type that are wet or slippery. Failure to comply may result in serious personal injury or death.

 WARNING

Fall Hazard. Use the three-point contact method (either two hands and one foot, or two feet and one hand on the ladder at all times) when climbing the ladder. Always face the ladder when climbing up or down. Failure to comply may result in serious personal injury or death.

 WARNING

Fall Hazard. Do not allow anyone but a trained operator to climb on ladders. Failure to comply may result in serious personal injury or death.

4. If equipped, turn the wash-out system ON.
5. Turn on the wash-out hose valve (Figure 73, Item 4).
6. Unfold the access ladder (Figure 73, Item 5).

NOTE: The fins, charge hopper, collector, and other components on the rear of the Mixer can be washed from the ground instead of standing on the platform.

 WARNING

High Pressurized Fluid Hazard. When using pressurized water, spray water at an angle to prevent splash-back. Never aim pressurized water toward another person. Failure to comply may result in serious personal injury or death.

7. Using the wash-out hose (Figure 73, Item 1), start at the top and wash out the charge hopper (Figure 73, Item 2), the interior of the drum, the main chute (Figure 73, Item 3), and chute extensions.

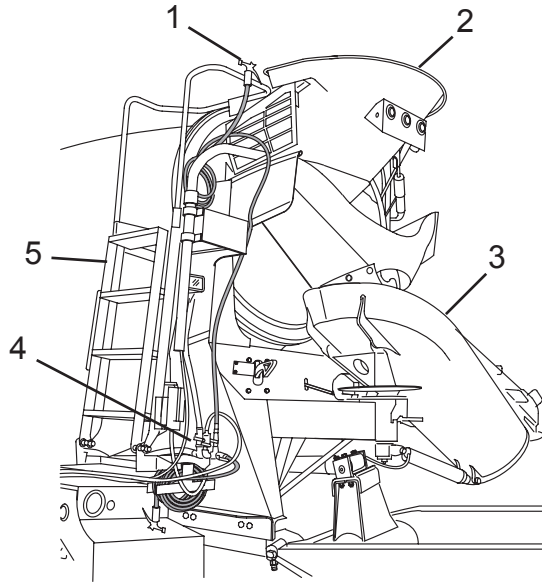

Figure 73

8. Check for concrete build-up; make a note of any concrete that cannot be washed out for future reference. Let the equipment manager know about excessive build-up.
9. Wash any spilled/splashed concrete and/or debris from the exterior of the drum, rear pedestal, fenders, and any surface of the Mixer as needed.

10. Remove and properly stow the chute extensions. Wash off any concrete that may have been missed before storing the chute extensions.
11. Turn off the wash-out hose valve.
12. Depressurize the water tank(s) and purge the water system.

WARNING

Never allow the water from the tank to drain onto a public sidewalk or roadway. Water may cause the sidewalk or roadway to become slippery. Always drain the water system at a location designated by the job site manager or in compliance with your company policy. Failure to comply may result in serious personal injury or death.

CAUTION

Be sure to drain the water system after each use when operating in temperatures below freezing. Failure to comply may cause damage to property or equipment.

13. If operating in temperatures below freezing, the water tank(s) must be drained. (See Draining the Water System for a pressurized water system or for a pump water system.)
14. Properly stow the wash-out hose(s).
15. Return the fold-over chute to the STORAGE position, and position and lock the main chute in the TRANSPORT position, using the manual chute lock.
16. Fold up the access ladder and make sure it is securely latched.

6.11 Returning from the Job Site

Before beginning travel from the job site back to the plant, be sure that the Mixer is properly prepared for travel.

This means that:

- All access ladders are folded up and securely latched
- Rear control pendant is properly stowed and secured
- All spilled concrete is washed off the Mixer
- Mixer and chassis surfaces are free of mud or debris that may be dropped on the road or thrown onto cars while driving

- Chute and chute extensions are clean and free of concrete and debris

DANGER

Crush Hazard. Chute extensions must be secured on the truck before leaving the job site. Failure to comply will result in serious personal injury or death.

- Chute extensions are properly stowed and secured
- Wash-out hose(s) is properly stowed and secured
- Main chute is positioned with the end of the chute pointing toward the curb, and is locked using the manual chute lock
- Water tank(s) is depressurized
- If operating in temperatures below freezing, the water tank(s) should be drained

CAUTION

Always rotate drum when truck is in motion. Never stop the drum while driving. Driving the truck without the drum rotating will damage equipment. Failure to comply may cause damage to property or equipment.

Operation

- Drum is rotating in the CHARGE direction (CW) and is set at the proper speed (approximately 1 to 1-1/2 RPM)

6.12 End-of-Day Cleaning Procedure

Keeping the drum clean is important to ensure proper operation and extend drum life. The drum should be cleaned thoroughly at the end of each work day. Use the following procedure that matches the type of drum installed on your Mixer.

6.12.1 Standard (Steel) Drum

1. Empty the mixer drum of all remaining contents per company policy.
2. Set drum to rotate at maximum speed in the CHARGE direction and add approximately 150 to 200 gallons (568 to 757 liters) of fresh or recycled water to the drum.
3. Run the drum at mixing speed for approximately two minutes.
4. Move the Mixer to the appropriate sedimentation pit or pond, or to a reclaimer. Change the drum rotation to the DISCHARGE direction and empty the drum contents.

5. If needed, add 30 to 40 gallons (114 to 150 liters) of water to the drum for a final rinse.
6. Wash the exterior of the Mixer.

6.12.2 End-of-Day Checks

At the end of the day, make certain that:

1. The Mixer drum and chutes are thoroughly washed out.
2. The water system is drained. (See Draining the Water System for a pressurized water system or for a pump water system.)
3. Place the drum drive in the neutral position before shutting down.
4. All equipment is properly shut down.
5. The truck is parked on a firm, level surface. (Refer to the Operator's Manual supplied by the chassis supplier for all shut-down and parking procedures.)
6. Report any mechanical/electrical/hydraulic problems to the appropriate people so that repairs can be made.

7.0 Water Tanks

7.1 Water Tank Safety

WARNING

IMPORTANT ALUMINUM AND STEEL WATER TANK INFORMATION.

1. Inspect water tank on a daily basis for any damage including, but not limited to, dents, gouges in metal, or leaks.
2. Do not weld on or repair water tank. Instead, replace water tank with a new OEM water tank.
3. Never pressure test an empty water tank. Only pressure test a full water tank.
4. Never remove pressure regulator or pressure safety valve from tank.
 - If regulator or safety valve is defective, it must be replaced before Mixer is put into service.
5. Do not pressurized water tank beyond its working pressure.

- If pressure exceeds the working pressure, immediately depressurize water tank and replace pressure regulator and pressure safety valve.
6. Never drive the truck with the water tank pressurized.
 - Depressurize water tank prior to transit to or from job site.
 - Water tank should be pressurized only when being used.
 7. Never modify water tank in any way.
 8. Immediately replace safety decals with OEM decals if decals are missing or difficult to read.
 9. Refer to the Revolution Operator's Manual or contact Revolution at (855) 202-6491 if you have questions or require assistance.

Operation

7.2 Water Tank Operation

7.2.1 Introduction

Your mixer may be equipped with a pressurized water tank. This tank is used to add water to a concrete mix, and to provide a source of water pressure for washing down the chutes and the drum. The air pressure from the truck's auxiliary air system is used to provide pressure to the tank. Use these instructions for the safe operation and inspection of all Revolution and London pressurized water tanks.

If your mixer is equipped with a non-pressurized water tank (a system that uses a water pump to provide pressure), refer to the instructions provided with the mixer.

7.2.2 Daily Operation

7.2.2.1 Tank Integrity

At the start of each shift:

- **Inspect Interior:** Drain the tank of water and use a flashlight to look into the tank through the fill opening. Look for signs of corrosion on the inside of the tank which may indicate that the tank has been weakened and is in need of replacement.

- **Inspect Exterior without Pressure:** If the interior inspection indicates that the tank is in good condition, fill the tank with water and inspect the exterior of the tank thoroughly for signs of leaks. Inspect the filler neck and fill opening. Look for signs of damage. Look for cracks in the weld joints or seams. Check that all fastening hardware is tight and undamaged. Inspect fittings for signs of damage, cracks, or looseness.
- **Inspect Exterior with Pressure:** If there are no signs of exterior leakage, pressurize the tank and repeat the inspection.
- **Depressurize Tank:** Release the pressure in the tank as soon as you are finished inspecting and before moving the truck.

Replace Defective Tank: Water tanks with any leak or significant signs of internal or external damage or corrosion should be replaced. **DO NOT ATTEMPT TO REPAIR.**

7.2.2.2 Pressure Regulator Valve

Inspect Pressure Regulator: The pressure regulator is used to reduce the air brake system pressure to a pressure that is safe to be used in the water tank. It must be undamaged and in proper working order. Look and listen for signs of leaking. Ensure that the valve and

associated hoses and fittings are undamaged.

Adjust Pressure to Correct Setting: Many pressure regulators are set at the factory and cannot be adjusted. If your water tank has an adjustable regulator, set it to 50 psi. When setting the regulator, always begin by turning the adjusting knob counterclockwise first to reduce the pressure slightly. Then turn it clockwise slowly to bring the pressure up to the correct setting. Never continue to turn the valve past the correct setting.

Replace Defective Regulator Valve: Any water tank with a damaged or missing pressure regulator valve must be removed from service immediately. Do not pressurize the tank until a functioning pressure regulator valve has been installed.

7.2.2.3 Pressure Relief Valve

Inspect the Relief Valve: The pressure relief valve is a safety device that will release air or water from the tank if it is inadvertently pressurized over the relief setting. The relief setting on most water tanks is set at the factory and cannot be adjusted. Identify the pressure relief valve and ensure that it has not been damaged or tampered with.

Replace Defective Relief Valve: Any water tank with a damaged or missing pressure relief valve must be removed from service immediately. Do not pressurize

the tank until a functioning pressure relief valve has been installed.

7.2.3 Daily Operation

The water tank is designed to be used during stationary operation at the yard or the job site only. It is not necessary or beneficial for the tank to be pressurized while driving, and a pressurized tank is an added hazard in the event of a crash or a rollover.

7.2.4 Vehicle Handling Characteristics

Safe operation of any vehicle is the responsibility of the driver. Concrete trucks have a significantly higher rollover tendency than other types of vehicles due to a higher center of gravity and the affect of concrete shifting in the drum. The water tank is also a fluid load that can increase the rollover tendency if the truck is driven with the water tank partially full. To reduce the risk of rollover, only drive a loaded truck (concrete in the drum) with the water tank either completely full or completely empty. Avoid making sharp turns at excessive speeds and other abrupt maneuvers.

In the event of a rollover or crash, an unbelted person is significantly more likely to become injured or die than a person wearing a seat belt. **ALWAYS WEAR YOUR SEAT BELT.**

7.3 Water Tank Safety Sign Identification

No.	Part Number	Qty.	Comments
A	1449162	1	Use if equipped with 55 psi tank.
A	1449165	1	Use if equipped with 95 psi tank.
A	1503949	1	Use if equipped with 120 psi tank.
B	1449164	1	

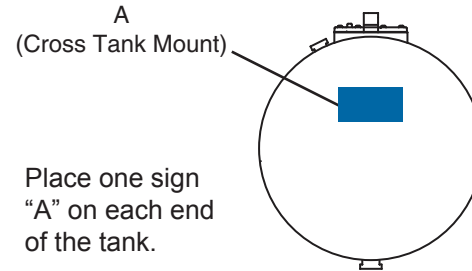
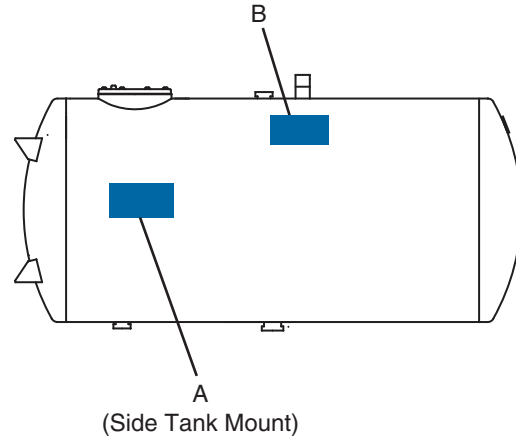

7.4 Water Tank Mounting Positions

The water tank(s) can be mounted in one of several locations, depending on the Mixer configuration and options.

7.5 Standard Water Tank

Mixers are equipped with at least one water tank to provide water for adjusting the slump and for cleaning. Additional water tanks are optional.

WARNING

NEVER drink the water from a water tank. The water tank may contain residue from chemicals used to modify concrete properties. Failure to comply may result in serious personal injury or death.

WARNING

NEVER modify the water tank(s) in any way. Failure to comply may result in serious personal injury or death.

7.5.1 Single Sight Gauge

The water tank sight gauge (Figure 74, Item 1) allows the operator to view the water level in the tank. The sight gauge is equipped with isolator valves (Figure 74, Items 2 and 3) that can isolate the sight gauge from the pressurized water tank in the event the sight gauge tube is broken.

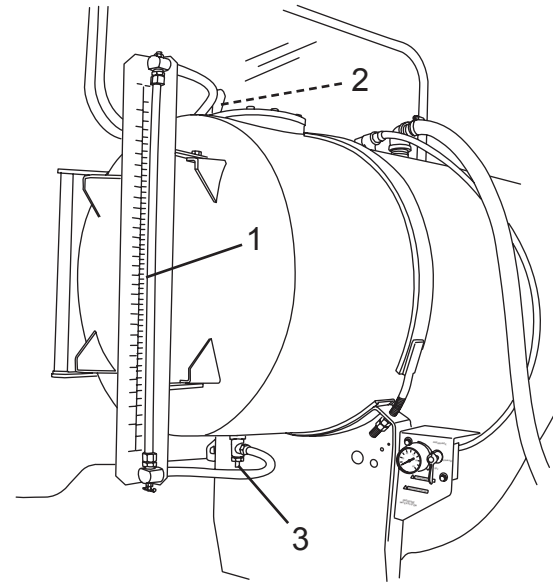

Figure 74

Operation

7.6 Split Water Tank (Optional)

Some Mixers can be equipped with a split water tank. This tank provides a main compartment for water and a smaller compartment (usually 15 or 25 gallon [57 or 95 liter] capacity) that may be used to hold a chemical solution.

7.6.1 Dual Sight Gauges

On Mixers equipped with split water tanks, the water tanks will have two sight gauges. One sight gauge will indicate the level of the chemical tank (Figure 75, Item 1). This tank can have a capacity of 15 or 25 gallons (57 or 95 liters).

The other sight gauge (Figure 75, Item 2) will indicate the level of the main water tank.

The sight gauges are equipped with isolator valves that can isolate the sight gauges from the pressurized water tank in the event a sight gauge is broken. Valves are located at the top and bottom of the sight gauges.

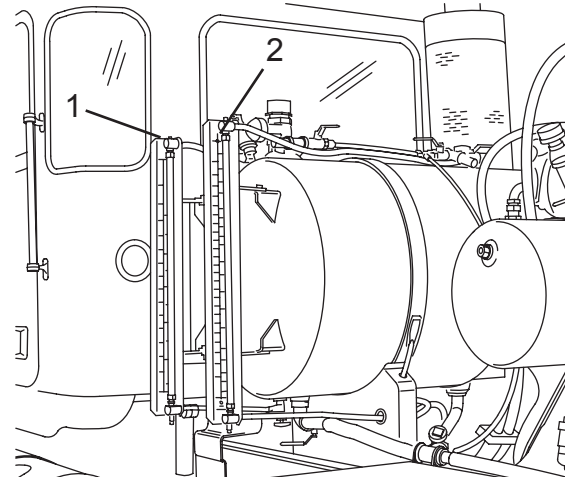

Figure 75

8.0 Water System - Pressurized

⚠ WARNING

High Pressure Fluid Hazard. Never drive the truck with the water tank pressurized. Failure to comply may result in serious personal injury or death.

8.1 Depressurizing the Water Tank

1. Turn air pressure control valve to EXHAUST position (Figure 76, Item 1). Make sure the gauge (Figure 76, Item 2) reads 0 psi (0 kPa).

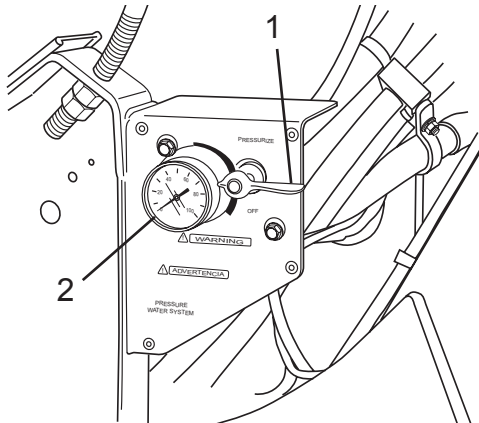

Figure 76

2. After pressure in the water tank has been completely exhausted, turn the air pressure control valve to the OFF position (Figure 77, Item 1).

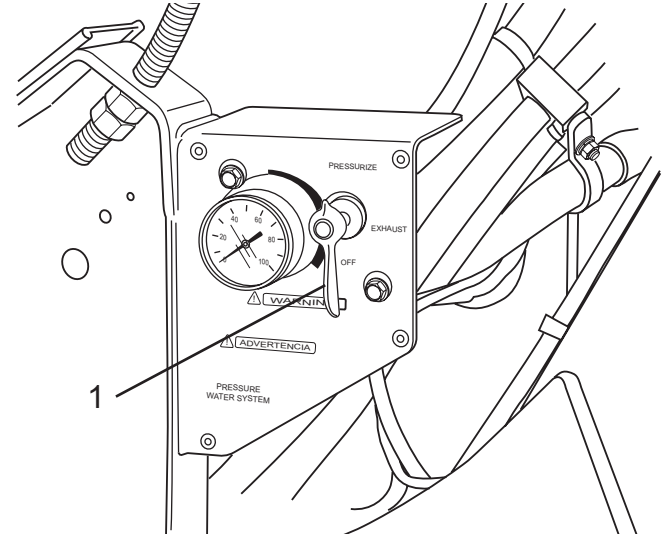

Figure 77

8.2 Pressurizing the Water Tank

1. Open the air valve (Figure 78, Items 1 or 2) of the tank compartment to be pressurized. If equipped with an optional split tank, each compartment will have its own valve.

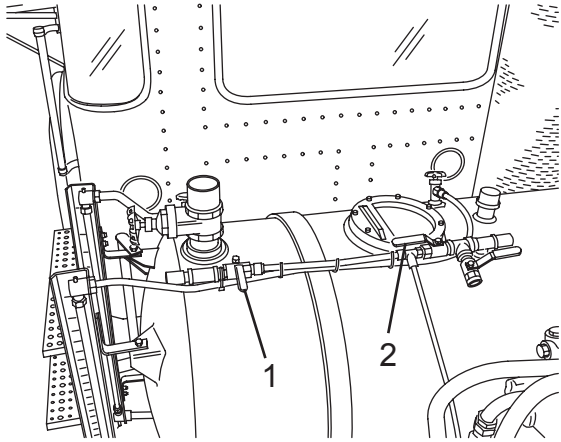

Figure 78

WARNING

Burst Hazard. Never pressurize water tank in excess of 55 psi (380 kPa). If pressure exceeds 55 psi (380 kPa), depressurize the water tank immediately and adjust or replace the air regulator valve. Failure to comply may result in serious personal injury or death.

2. Turn air pressure control valve to the PRESSURIZE position (Figure 79, Item 1). The water tank will be pressurized from the chassis air system. The air gauge (Figure 79, Item 2) will indicate the pressure in the water tank. The pressure must not exceed 55 PSI (380 kPa).

WARNING

Burst Hazard. Never pressurize an empty water tank. Failure to comply may result in serious personal injury or death.

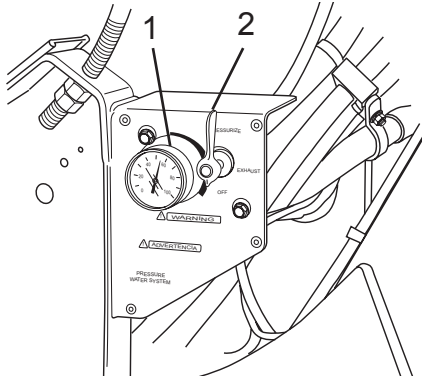

Figure 79

8.3 Draining the Water System

WARNING

Never allow the water from the tank to drain onto a public sidewalk or roadway. Water may cause the sidewalk or roadway to become slippery. Always drain the water system at a location designated by the job site manager or in compliance with your company policy. Failure to comply may result in serious personal injury or death.

CAUTION

Be sure to drain the water system after each use when operating in temperatures below freezing. Failure to comply may cause damage to property or equipment.

NOTE

When draining the chemical tank, the contents should be drained into a properly marked container. The container should be stored for reuse, or the contents should be disposed of in compliance with all applicable regulations.

When operating in temperatures below freezing, the water system must be drained after every use.

1. Depressurize the water tank(s).
2. Remove the water tank drain plug(s), or open the main tank (Figure 80, Item 5) and chemical tank (if equipped) drain valves (Figure 80, Item 3).
3. Open the main tank (Figure 80, Item 4) and chemical (if equipped) sight glass isolator valves (Figure 80, Item 2).
4. Open the sight glass drain valves (Figure 80, Item 1).

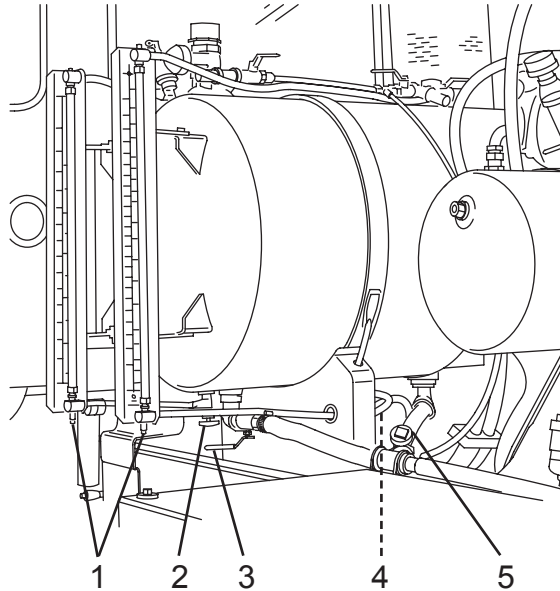

Figure 80

5. Open wash-out hose valve (Figure 81, Item 3) at the rear of the Mixer and allow water to drain.
6. Open drum wash-out valve (if equipped) (Figure 81, Item 1), and add-water valve (Figure 81, Item 2) and allow water to drain.

7. Open all valves controlling water flow to optional equipment such as water meters.

NOTE

Apply thread sealant tape or thread sealant compound to the drain plug threads before installation.

8. When no more water comes from the tank drain(s) and water nozzles, install the water tank drain plug(s). Tighten the plug until snug.
9. Close the sight glass drain valves.
10. Close the drum wash-out valve (if equipped) (Figure 81, Item 1) and add-water valve (Figure 81, Item 2).
11. Pressurize water tank(s) to approximately 10–20 psi (69–138 kPa). Allow water to drain from wash-out hose.
12. Depressurize the water tank(s).

NOTE

Inspect hoses for low points that may retain water, even after the system has been drained. If a low spot is noted, have your service department reposition hoses to eliminate the low spot.

13. Open the drain petcock located at the lowest point in the supply hose (Figure 81, Item 4).

NOTE

If possible, drain and remove wash-out hose(s), and store hose(s) in the cab.

14. Open all water valves and make sure the water tank is depressurized.

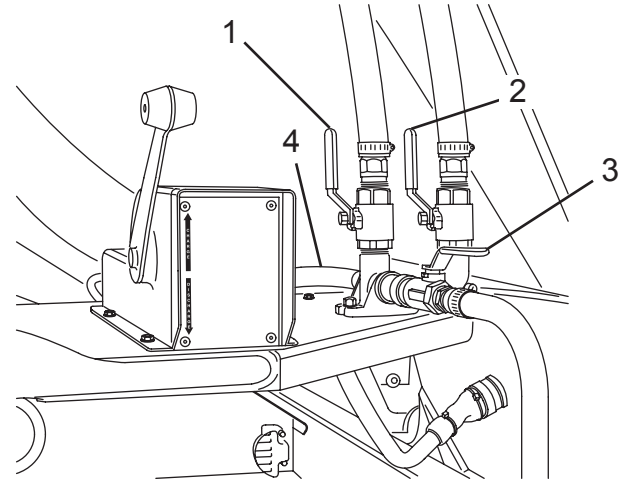

Figure 81

8.4 Filling the Main Tank

1. Depressurize the water tank.
2. Place the water supply hose in the water tank flopper valve (Figure 82, Item 1).

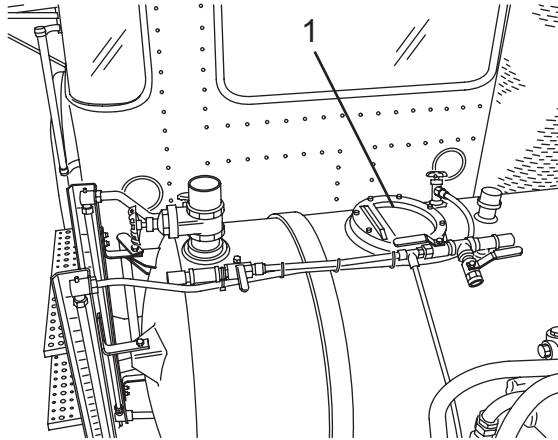

Figure 82

3. Open the water supply valve and fill the water tank.
4. Close the water supply valve.
5. Remove the supply hose from the valve.
6. Pressurize the water tank.
7. Inspect the water system for leaks.

⚠ WARNING
If damaged, corroded, or leaking, the water tank must be replaced with an OEM water tank from Revolution Concrete Mixers. Failure to comply may result in serious personal injury or death.

8. Depressurize the water tank before leaving for the job site.

8.5 Filling the Chemical Tank (Split Tank Option)

NOTE
Check with the batch plant operator for the proper type and amount of chemical required for the load.

The chemical tank is used to store additives needed to change the properties of the concrete. These additives may include plasticizers or retardants.

1. Depressurize the water tank.
2. Open the chemical tank gate valve (Figure 83, Item 1) and add the chemical through the inlet (Figure 83, Item 2).

3. Close the chemical tank gate valve.
4. Pressurize the water tank.
5. Inspect the water system for leaks.

 **WARNING**

If damaged, corroded, or leaking, the water tank must be replaced with an OEM water tank from Revolution Concrete Mixers. Failure to comply may result in serious personal injury or death.

6. Depressurize the water tank before leaving the job site.

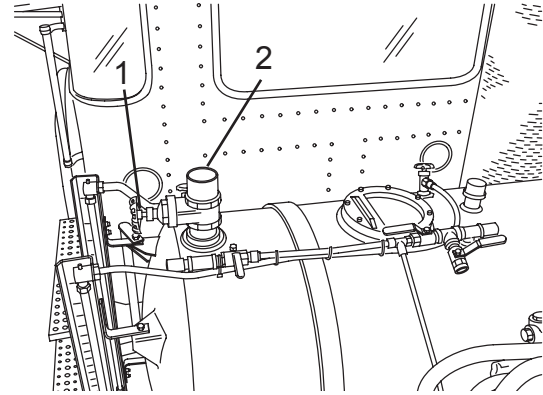

Figure 83

9.0 Water System - Pump

WARNING

Never attempt to repair the water tank. Never apply a weld procedure to a water tank. Replace water tank immediately if damaged. Failure to comply may result in serious personal injury or death.

The tank (Figure 84, Item 1) is not pressurized at any time. The water is drawn from the tank and pressurized by the air-powered diaphragm pump (Figure 84, Item 2).

The tank is equipped with one or more breathers (Figure 84, Item 3) that must be kept clean to ensure adequate water flow.

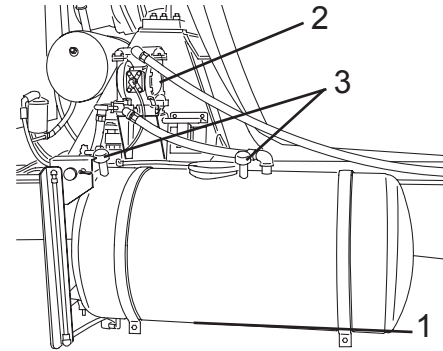

Figure 84

9.1 Pump Operation

The pump is powered by compressed air supplied by the chassis air compressor.

To operate the pump:

1. Start the truck and check to make sure the air pressure gauge is supplied with 100 psi (689 kPa) of pressure.
2. Close the purge valve (Figure 85, Item 1) at the pump inlet.
3. Open the main tank ball valve (Figure 85, Item 2) or chemical tank ball valve (Figure 85, Item 3) (if equipped) for the desired tank/water source.

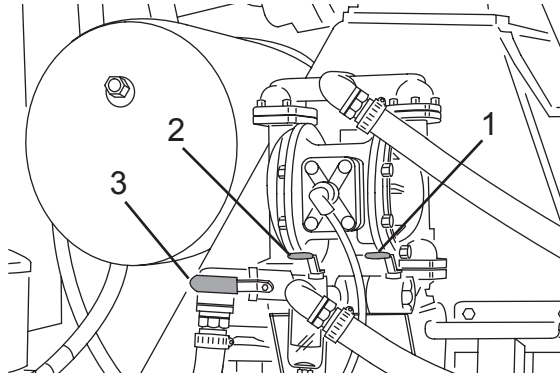

Figure 85

⚠ WARNING

Never pressurize a vessel not designed to be pressurized. Never modify water tank in any way. Failure to comply may result in serious personal injury or death.

NOTE

Trucks equipped with composite tanks will have the air pressure control valve mounted directly on the pump assembly. Turn off pump when not in use.

4. Turn the air pressure control valve (Figure 86, Item 1) to the PRESSURIZE position to start the pump.
To stop the pump, turn the air pressure control valve (Figure 86, Item 1) to the OFF position.

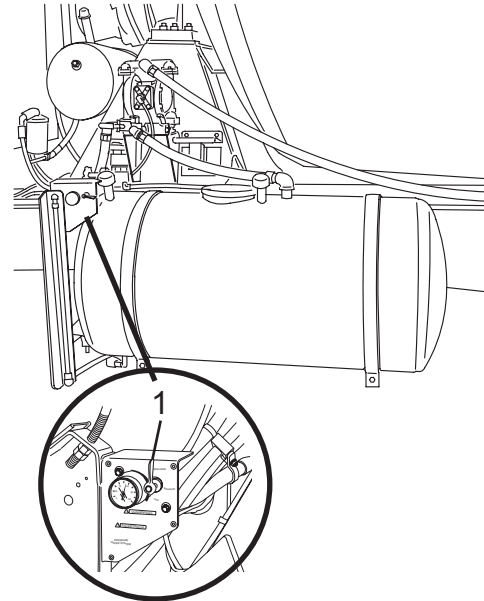

Figure 86

Operation

5. Open the upper wash-out valve (Figure 87, Item 1), “Add Water” valve (Figure 87, Item 2), or lower wash-out valve (Figure 87, Item 3) to activate the desired function.

CAUTION

Be sure to drain the water system after each use when operating in temperatures below freezing. Failure to comply may cause damage to property or equipment.

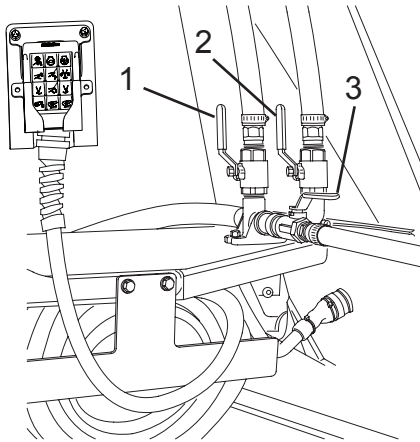

Figure 87

9.2 Filling the Water Tank

1. Turn the pump off by turning the air pressure control valve to the OFF position.
2. Place the water supply hose in the water tank flopper valve (Figure 88, Item 1) and fill the tank.

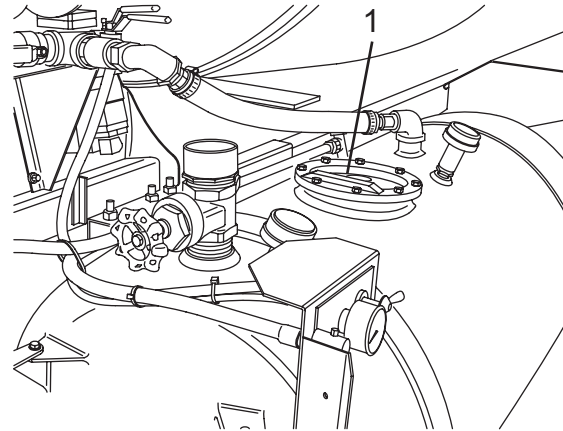

Figure 88

3. Close the water supply valve.
4. Remove the supply hose from the flopper valve.
5. Inspect the water system for leaks.

⚠ WARNING

If damaged, corroded, or leaking, the water tank must be replaced with an OEM water tank from Revolution Concrete Mixers. Failure to comply may result in serious personal injury or death.

9.3 Filling the Chemical Tank - Steel or Aluminum Tanks (Split Tank Option)

NOTE

Check with the batch plant operator for the proper type and amount of chemical required for the load.

The chemical tank is used to store additives needed to change the properties of the concrete. These additives may include plasticizers or retardants.

1. Turn the pump off by turning the air pressure control valve to the OFF position.
2. Open the chemical tank gate valve (Figure 89, Item 2) and fill the chemical through the inlet (Figure 89, Item 1).
3. Connect a water supply hose to the inlet (Figure 89, Item 1) and fill tank.

4. Close the water supply valve.
5. Remove the supply hose from the tank.
6. Inspect the water system for leaks.

⚠ WARNING

If damaged, corroded, or leaking, the water tank must be replaced with an OEM water tank from Revolution Concrete Mixers. Failure to comply may result in serious personal injury or death.

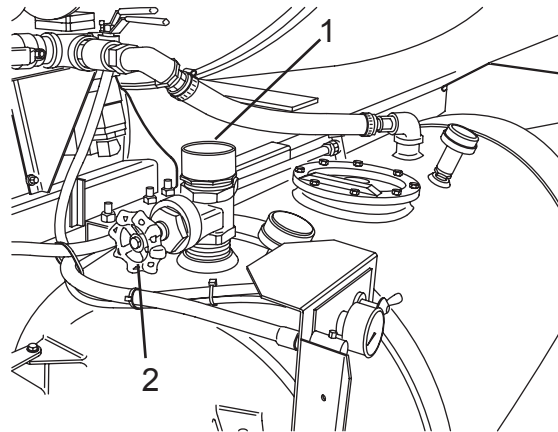

Figure 89

9.4 Draining the Water System

WARNING

Never allow the water from the tank to drain onto a public sidewalk or roadway. Water may cause the sidewalk or roadway to become slippery. Always drain the water system at a location designated by the job site manager or in compliance with your company policy. Failure to comply may result in serious personal injury or death.

CAUTION

Be sure to drain the water system after each use when operating in temperatures below freezing. Failure to comply may cause damage to property or equipment.

NOTE

When draining the chemical tank, the contents should be drained into a properly marked container. The container should be stored for reuse, or the contents should be disposed of in compliance with all applicable regulations.

When operating in temperatures below freezing, the water system must be drained after each use.

1. Park the truck on a firm, level surface to allow proper drainage.

NOTE

The purge valve should be angled down slightly to permit proper drainage. If the valve is not positioned properly, have your service department reposition the valve/tee fitting assembly.

2. Open the main tank ball valve (Figure 90, Item 2) and chemical tank ball valve (Figure 90, Item 1) (if equipped).

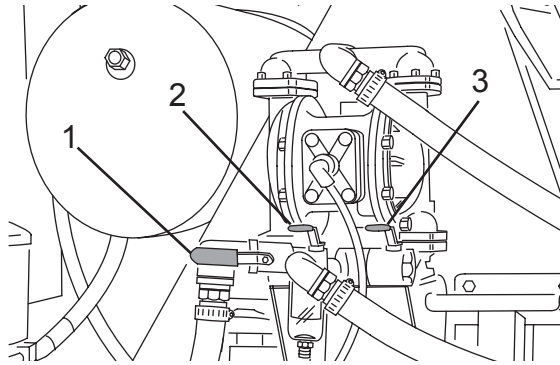

Figure 90

3. Remove the water tank drain plug(s) (Figure 91, Items 3 and 5), or open the drain valve(s) (if equipped).
4. Open the main tank (Figure 91, Item 4) and chemical tank (if equipped) (Figure 91, Item 2) sight glass isolator valves.
5. Open the sight glass drain valve(s) (Figure 91, Item 1).

NOTE

Apply thread sealant tape or thread sealant compound to the drain plug threads before installation.

6. When no more water comes from the tank drain(s), install the water tank drain plug(s) (Figure 91, Items 3 and 5). Tighten the plug(s) until snug.
7. Close the sight glass drain valve(s) (Figure 91, Item 4).

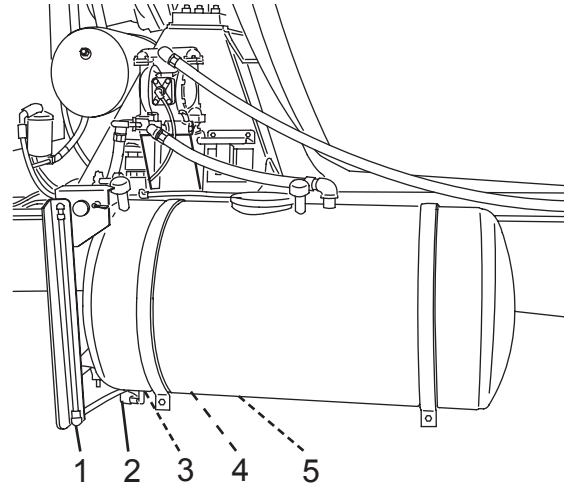

Figure 91

8. Start the truck and check to make sure the air pressure gauge is supplied with 100 psi (689 kPa) of pressure.

Operation

- Turn the pump on by turning the air pressure control valve to the PRESSURIZE position.
- Close the main tank ball valve (Figure 92, Item 2) and chemical tank ball valve (Figure 92, Item 1) (if equipped).
- Open the purge valve (Figure 92, Item 3).

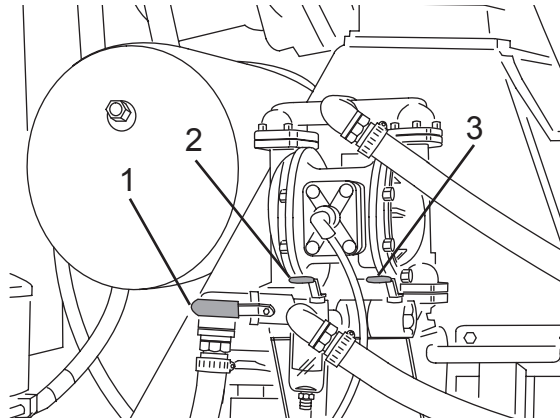

Figure 92

- Open wash-out hose valve (Figure 93, Item 3) at the rear of the Mixer and allow water to drain.
- Open wash-out valve (Figure 93, Item 1) and add-water valve (Figure 93, Item 2) and allow water to drain through wash-out hose.

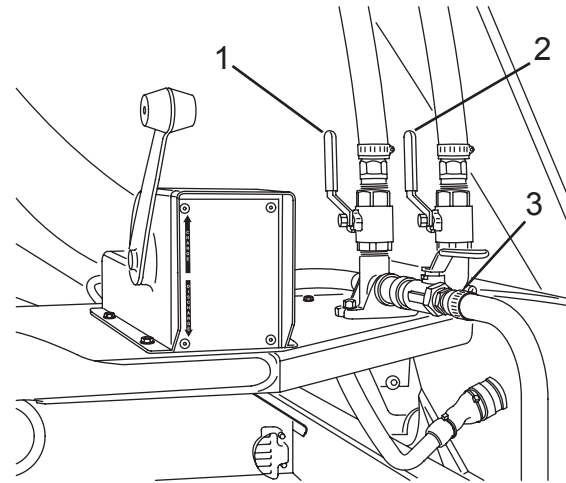

Figure 93

NOTE

Inspect hoses for low points that may retain water, even after the system has been drained. If a low spot is noted, have your service department reposition hoses to eliminate the low spot.

- Open the drain petcock located at the lowest point in the supply hose (Figure 94, Item 1).

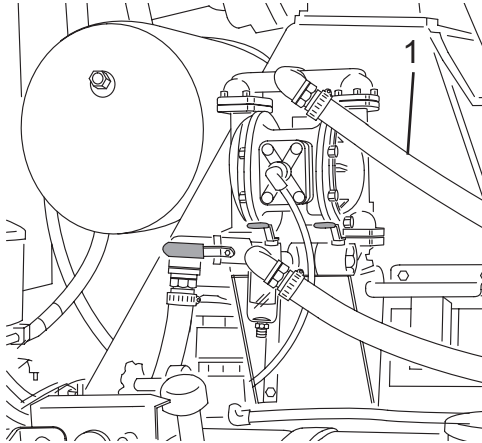

Figure 94

15. Turn the pump off by turning the air pressure control valve to the OFF position.

NOTE

If possible, drain and remove wash-out hose(s), and store hose(s) in the cab.

16. Open all water control valves and outlets and leave them open until the next use.

10.0 Water System Functions

10.1 Wash-Out Hoses (Optional Equipment)

The wash-out hose provides a means for cleaning the mixer system after completing a delivery.

The Mixer is equipped with a hose (Figure 95, Item 5) at the rear of the Mixer. The flow to the hose is controlled by a ball valve (Figure 95, Item 1). The Mixer may also be equipped with additional (optional) hoses.

NOTE: The fins, charge hopper, collector, and other components on the rear of the Mixer can be washed from the ground using the wash-out hoses instead of standing on the platform.

10.1.1 Upper Wash-Out Hose

An optional upper water hose (Figure 95, Item 4) is available to make cleaning of the charge hopper and drum easier.

The flow to the hose is controlled by a ball valve (Figure 95, Item 2) located at the rear of the Mixer.

Operation

10.1.2 Front Wash-Out Hose

An optional front water hose is available to make cleaning of the front of the Mixer easier, or to use as auxiliary water source on the pour site.

The flow to the hose is controlled by a ball valve located at the front of the Mixer.

10.1.3 Valve Drain

The valves may be equipped with a drain option. This feature automatically drains the water from the hose beyond the valve, through a small hole at the rear of the valves (Figure 95, Item 3).

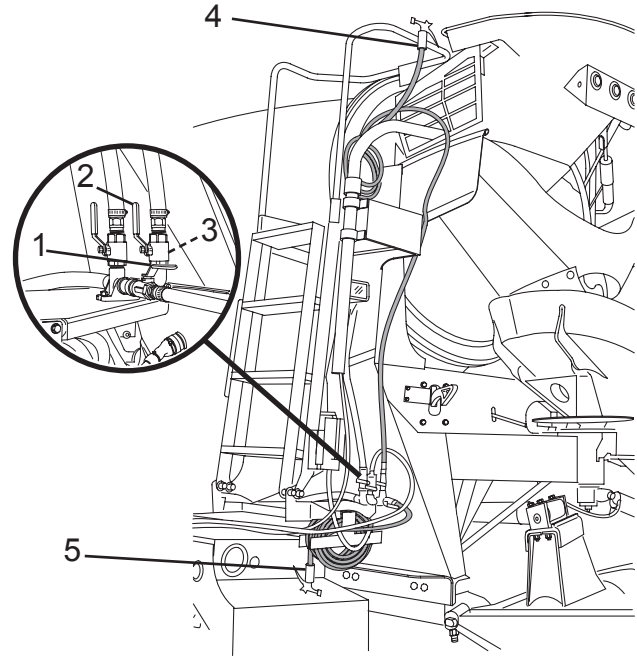

Figure 95

10.2 Auto Washout System for INSIGHT System (Optional Equipment)

An optional auto washout system for INSIGHT controlled Mixers is available to make cleaning of the Mixer easier.

NOTE: If the auto washout system is active (the Start button has been pressed), the INSIGHT System charges the drum. Once the washout cycle is complete, or the Stop button has been pressed, the operator can resume controlling the drum with the regular inputs (joystick, keypad, etc.).

1. Check all water lines are open and not damaged or leaking, and check the water level in the water tank.
2. On the INSIGHT display screen, enter the Slump Screen (press on the gauges).
3. Select “Washout” (Figure 96).



Figure 96

4. Select up to two different components of the Mixer to wash at a time (Figure 97). (Only two components can be washed at the same time.)

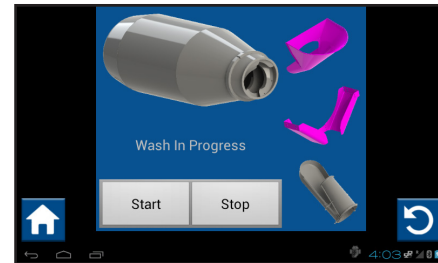

Figure 97

⚠ WARNING

Before starting the wash cycle, ensure the area around the mixer drum is clear of personnel. If the drum is not already turning, the drum will start turning in the charge direction when the wash cycle is started. Failure to comply may result in serious personal injury or death.

5. Press the Start button to begin auto wash down of the selected components. A “Wash In Progress” message will display on the screen. (See Figure 98.)

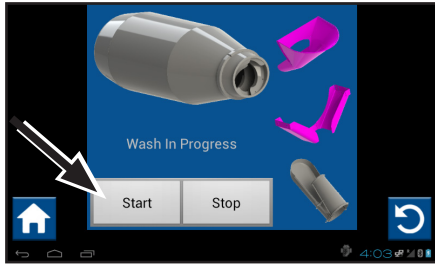

Figure 98

6. When the wash down cycles have completed, a “Wash Complete” message will display on the screen (Figure 99).



Figure 99

NOTE: The wash out cycle can be stopped by pressing the Stop button. This cancels the wash cycle; pressing Start will begin a new wash cycle.

NOTE: If desired, adjust washout time settings per component in the Slump Options screen (Figure 100). Access the Slump Options screen by pressing the Administrator button on the Home screen, then press the Options button. On the Diagnostics Menu screen that pops up, press the Slump button to enter the Slump Options screen.

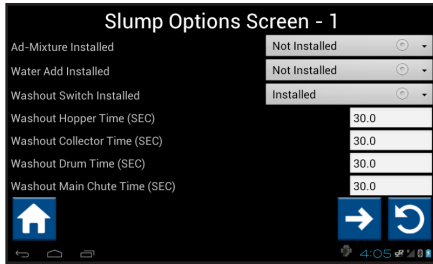

Figure 100

10.3 Manual Washout System

Mixers may be equipped with an optional manual washout system that manually uses levers (Figure 101) to control the washing out of the hopper, collector, main chute, and drum/fin areas. This system may also be equipped with levers to control the add water feature and the upper washout hose. This manual washout system is available to make cleaning of the Mixer easier.

1. Check all water lines are open and not damaged or leaking, and check the water level in the water tank.
2. Turn on the water pump.
3. Move the lever from the closed position to the open position for the area you wish to washout.

4. When the washing out of that area is complete, move the lever from the open position to the closed position.

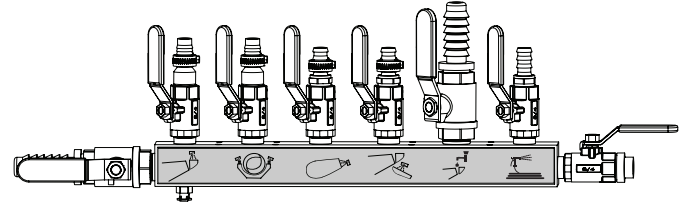

Figure 101

NOTE: More than one area may be washed out at the same time.

10.4 Spray Bar (Optional)

Mixers may be equipped with an optional spray bar (Figure 102, Item 1). The spray bar allows water to be sprayed on the drum to cool the drum. The spray prevents the concrete from setting up prematurely in warm climates.

The flow of water to the spray bar is controlled by a ball valve (Figure 102, Item 2).

Do not use the spray bar during transit.

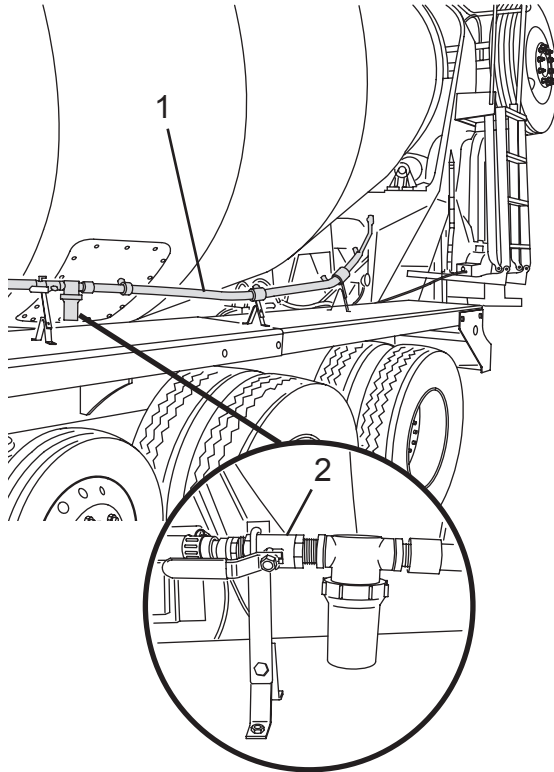

Figure 102

10.5 Water Meter Function (Optional)

Mixer may be equipped with an optional water meter to allow monitoring of water used. There are four types of meters available: Precision, BR Industries, GPI®, and Signet.

10.5.1 Precision Water Meters

The Precision PMM™ water meter (Figure 103) is installed directly in the water supply line to monitor the amount of water used.

The meter has a built-in register that is protected by a cover. The register records the amount of water used.

The counter records the number of gallons used to 1/10 of a gallon (0.4 liter).

To read the meter:

1. Before discharging water, record the counter reading and the position of the sweep hands on the “10” and “1” (tenths of a gallon) counters:
 - a. Record the reading from the counter (Figure 103, Item 1), in this case 220 gallons (833 liters).
 - b. Add the reading from the sweep hand on the “10” counter (Figure 103, Item 2), in this case 1 gallon (3.8 liter).
 - c. Add the reading from the sweep hand on the “1” (tenths of a gallon) counter (Figure 103, Item 3), in this case 0.1 gallon (0.4 liter). The actual reading of the meter is 221.1 gallons (836 liters).
2. Discharge water as needed until the desired amount of water is determined from the original meter reading.

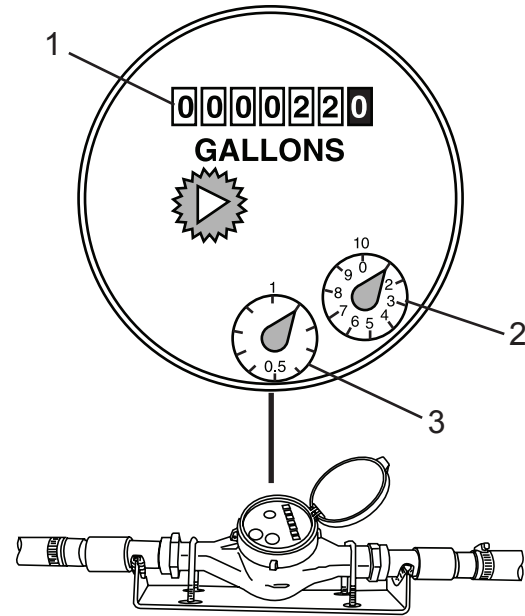

Figure 103

Operation

10.5.2 BR Industries (BM-25) Water Meter

The BM-25 meter is installed directly in the water supply line to monitor the amount of water used.

CAUTION

Do not exceed the manufacturer's temperature requirements per the water meter installed on your vehicle. Failure to comply may cause damage to property or equipment.

The meter has a display that is protected by a cover. The meter displays the amount of water used in gallons and liters.

To use the meter:

1. Slide the retaining strap (Figure 104, Item 1) to one side and open the cover (Figure 104, Item 2).

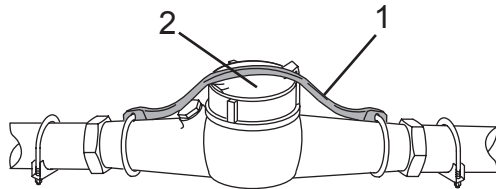

Figure 104

2. Reset the display by turning the collar (Figure 105, Item 1) counterclockwise until the pointer is aligned with "0".
3. Discharge water until the desired amount of water is displayed on the meter.

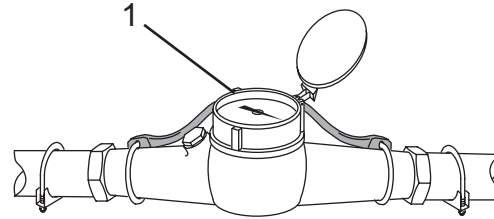

Figure 105

4. Close the cover (Figure 104, Item 2) and secure using the retaining strap (Figure 104, Item 1).

10.5.3 GPI® Water Meters

The GPI® water meter (Figure 106, Item 1) is installed directly in the “Add Water” line to monitor the amount of water added to the mixer drum.

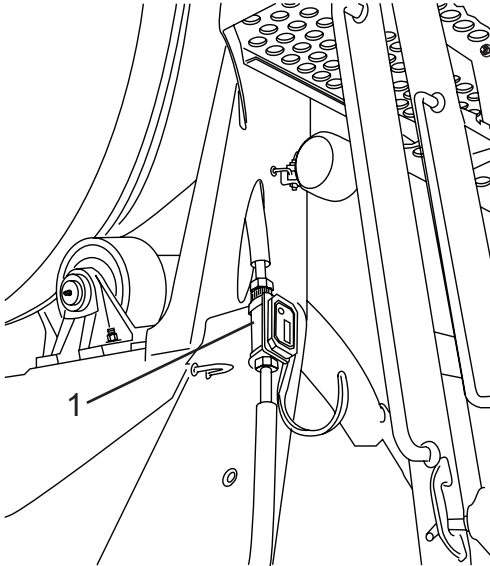

Figure 106

The meter is activated automatically when water flows through the meter. The meter can be manually activated by briefly pressing the DISPLAY button (Figure 107, Item 1).

The meter records two flow totals measured in gallons: “Batch” and “Cumulative.”

The “Batch” total (Figure 107, Item 3) is a record of flow used during a single use. When the meter is in “Batch” mode, “TTL1” (Figure 107, Item 2) will be displayed in the upper left corner of the meter display. This reading can be reset.

The “Cumulative” total is a record of continuous flow usage, from usage to usage. This is displayed as “TTL2” on the meter display. This setting cannot be reset; however, the display will reset to zero after the display reaches “9999.”

The meter is powered by two AAA alkaline batteries. If power is lost, the “Batch” and “Cumulative” totals will reset to zero.

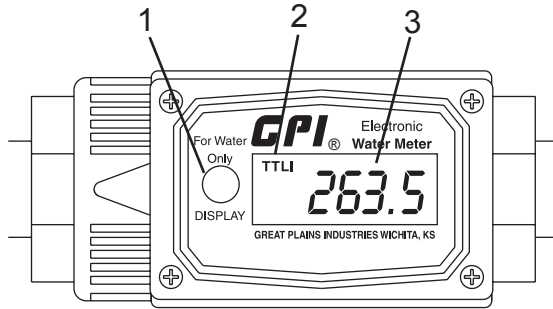

Figure 107

The meter has a power-saving feature, and will automatically shut off after one minute if no usage is detected.

To select display modes:

NOTE: On power-up, the meter will display the last total accessed during the previous use.

1. Activate the display by briefly pressing the DISPLAY button (Figure 108, Item 1).
2. Briefly press the DISPLAY button (Figure 108, Item 1) to change the total displayed - “Batch” mode (displayed as “TTL1”) or “Cumulative” mode (displayed as “TTL2”) (Figure 108, Item 2).

3. To reset the “Batch” total display, press and hold the DISPLAY button (Figure 108, Item 1) for three seconds.

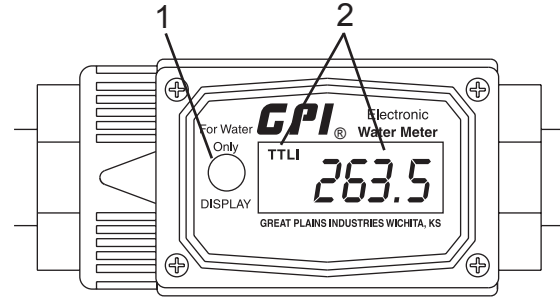

Figure 108

10.5.4 UFM Water Meters

For UFM water meters, the information for the amount of water added will be saved in the display mix log, recorded by time and date.

10.5.5 Operation

1. Before discharging, press the reset switch (Figure 109, Item 1) to reset the counter display (Figure 109, Item 2).
2. Discharge water as needed until the desired amount of water is displayed.

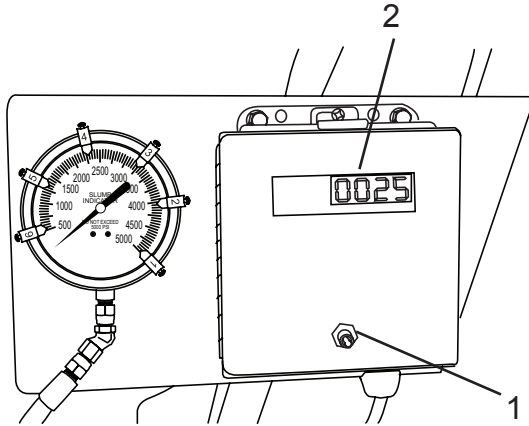

Figure 109

11.0 Optional Equipment

11.1 Hydraulic Fold-Over Chute

The hydraulic fold-over toggle switch (Figure 110, Item 1) enables the operator to fold or unfold the fold-over chute (Figure 110, Item 2) using a hydraulic cylinder.

WARNING

Crush Hazard. Do not let persons, other than the driver, handle the chutes, unfold the fold-over, and/or remove extension, or stow and secure the extensions for transit. Keep hands away from chute hardware where the chutes connect. Never stand in the path of the chute as it is being unfolded or while in use. Failure to comply may result in serious personal injury or death.

CAUTION

Do not move the vehicle with the fold-over chute extended and chute extensions installed. Failure to comply may cause damage to property or equipment.

To unfold the chute:

1. Position the chute so that there is sufficient room behind the chute. Lock the main chute using the manual chute lock or the optional chute air lock.
2. Remove the fold-over retaining chain.
3. Press and hold the fold-over toggle switch (Figure 110, Item 1) until the fold-over chute (Figure 110, Item 2) is fully seated against the main chute.

Operation

4. Release the switch.

To fold the chute:

1. Press and hold the fold-over toggle switch (Figure 110, Item 1) until the fold-over chute (Figure 110, Item 2) is fully seated against the main chute. Release the switch.
2. Secure the fold-over chute to the main chute with the retaining pin.
3. Stow and lock the main chute using the manual chute lock or the optional chute air lock.

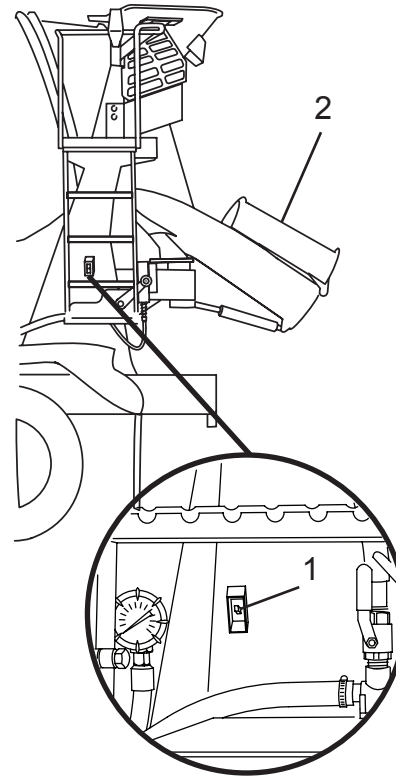

Figure 110

11.2 Chute Assist

The fold-over chute assist operates on a manual pulley to lower the fold-over chute into position.

To unfold the chute:

1. Unlatch the securing hook.
2. Grip the fold-over chute using the correct hand-holds (Figure 111).
3. Slowly lower the chute into operation position (Figure 112).

To fold the chute:

1. Grip the fold-over chute using the correct hand-holds (Figure 112).
2. Slowly raise the chute into stored position (Figure 113).
3. Latch the securing hook.

NOTE: The securing hook needs to be latched on the hand hold of the fold-over chute.

WARNING

Crush Hazard. The chute assist has pinch points between the main chute and the fold-over chute. Keep hands away from chute hardware where chutes connect. Keep hands away from the pulley system. Failure to comply may result in serious personal injury or death.

WARNING

Crush Hazard. Do not let persons, other than the driver, handle the chutes, unfold the fold-over, and/or remove extension, or stow and secure the extensions for transit. Keep hands away from chute hardware where the chutes connect. Never stand in the path of the chute as it is being unfolded or while in use. Failure to comply may result in serious personal injury or death.

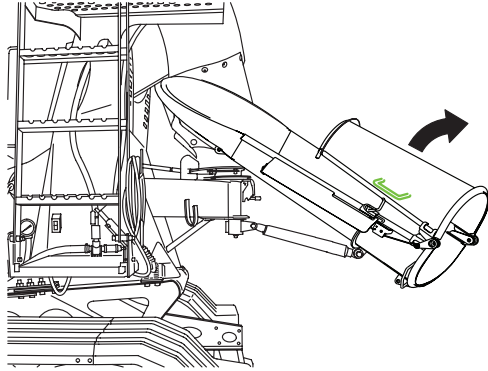

Figure 111

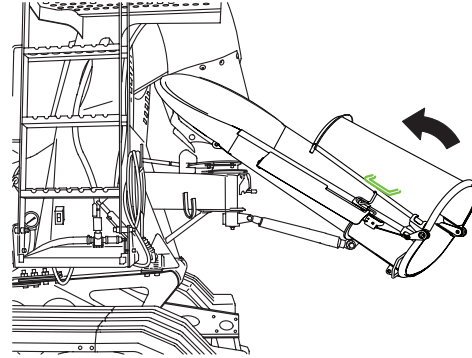

Figure 113

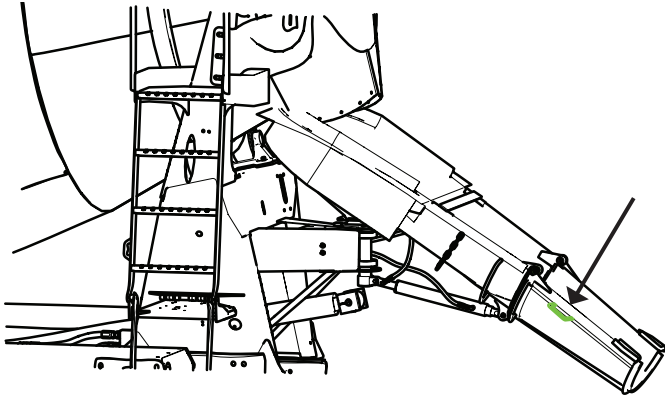

Figure 112

11.3 Hydraulic Chute Swing

The hydraulic chute swing option (Figure 114, Item 1) allows the operator to move the discharge chute from the rear pendant.

To engage the chute swing option:

1. Release the manual chute lock (Figure 114, Item 2).
2. Release the chute air lock. (See Cab Pendant Controls or Rear Pendant Controls for more information.)
3. Press the CHUTE SWING LEFT or RIGHT buttons on either the cab control or rear pendant to engage the chute swing drive. Release the button when the chute reaches the desired position. (See Cab Pendant Controls or Rear Pendant Controls for more information.)

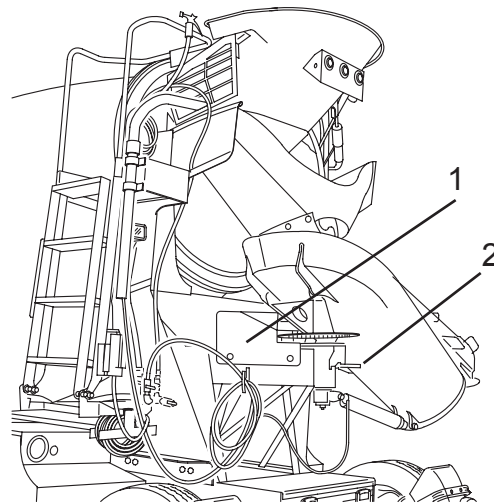

Figure 114

WARNING

Air chute lock is intended for use only on the job site. The manual chute lock should always be engaged during transport. Failure to comply may result in serious personal injury or death.

4. Engage the chute air lock.

11.4 Discharge Chute Vibrator Valve

When the chute vibrator valve (Figure 115, Item 1) is placed in the OPEN position, air pressure is supplied to the chute vibrator. This assists stiff slump concrete to flow down the chute.

SAFETY NOTICE

Operating the chute vibrator without concrete in the chute may cause damage to equipment.

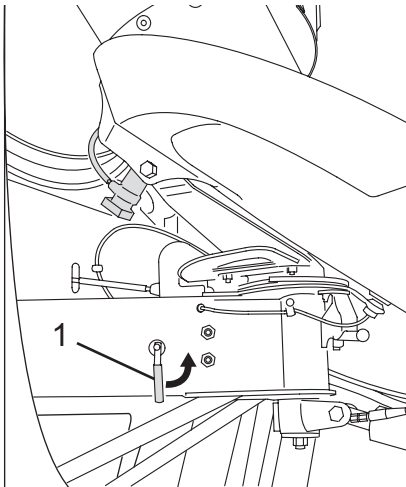

Figure 115

11.5 Chute Blockers

Discharge chute blockers prevent concrete or other debris from dropping off the main chute during transport (Figure 116). The chute blocker will automatically open when the fold-over chute is unfolded, and will close automatically when the fold-over chute is folded.

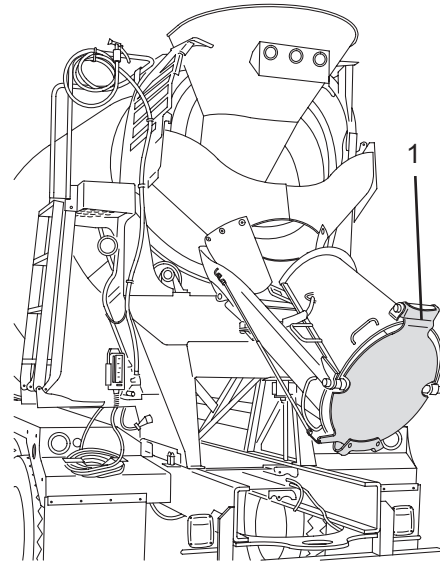

Figure 116

11.6 Fold-over Stop

The optional fold-over chute stop provides an additional margin of safety from pinch hazards when unfolding the fold-over chute.

As the chute is unfolded, the fold-over chute stop tab (Figure 117, Item 1) will make contact with the main chute, preventing the chute from slamming down against the main chute.

When the chute is raised, the fold-over chute stop will automatically release.

WARNING

Pinch Hazard. Remove hands, fingers, and any obstructions from the gap between the main and fold-over chutes before releasing the fold-over stop. Failure to comply may result in serious personal injury or death.

To release the fold-over chute stop:

1. Support the fold-over chute (Figure 117, Item 2).
2. Depress the handle (Figure 117, Item 3) until the stop tab (Figure 117, Item 1) clears the main chute, and lower the fold-over chute.

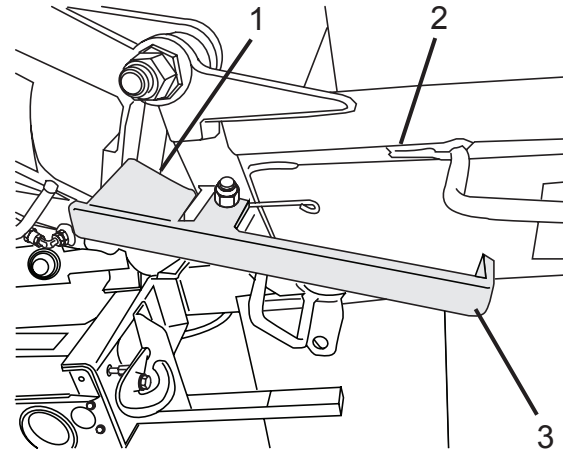

Figure 117

11.7 Flip-Up Charge Hopper

CAUTION

A raised hopper may cause overhead clearance problems. Always lower the flip-up hopper when not in use. Failure to comply may cause damage to property or equipment.

The flip-up charge hopper (Figure 118, Item 1) allows the charge hopper to be moved up to allow improved discharge of low slump concrete.

The flip-up charge hopper can be controlled either from the cab controls, or from the rear of the Mixer from the drum control or optional rear pendant.

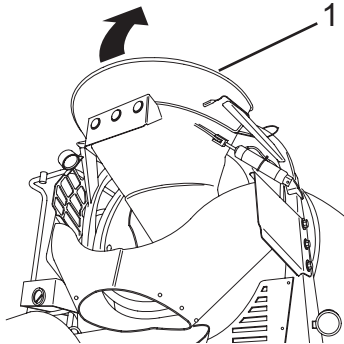

Figure 118

11.8 Swing Away Throat (SAT) Charge Hopper

The Swing Away Throat charge hopper (Figure 119, Item 1) allows the lower section of the charge hopper to move back (away from the drum opening). This allows improved discharge of low slump concrete without raising the entire charge hopper.

The Swing Away Throat charge hopper can be controlled either from the standard in-cab control keypad, or from the rear pendant keypad.

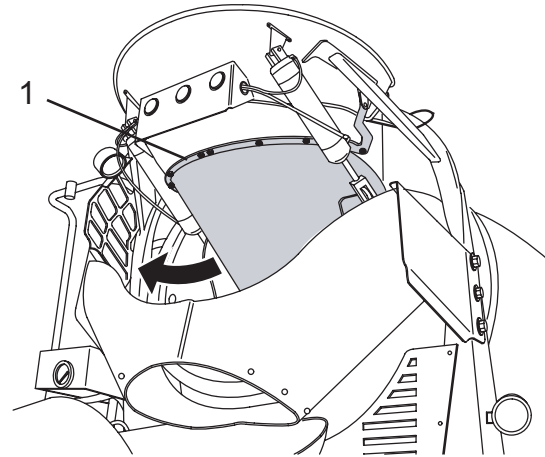

Figure 119

11.9 Right Hand Turn Audible Warning System

This optional system sends a audible message through a speaker mounted on the right hand front fender support any time the right hand turn signal is activated. The audible message is “CAUTION: VEHICLE TURNING RIGHT! ATENCION: VEHICULO GIRANDO A LA DERECHA!”

11.10 Lateral Protection Device

The rails on the lateral protection device (LPD) are designed to be removable for service of the vehicle. In addition, the bottom rail can be rotated up for increased ground clearance at the job site. **IMPORTANT:** The only time the LPD should be removed or rotated is when the vehicle is stationary. Return all parts of the LPD to their original positions before moving the vehicle.

Remove the LPD for Service

1. To remove the rails to perform service work on the vehicle, remove the pins and move the device out of the way.
2. Reinstall the device and the pins to return the LPD to its original position before moving the vehicle.

Rotate the Bottom Rail of the LPD Up

1. To rotate the bottom rail of the lateral protection device up for increased ground clearance, hold onto the rail assembly and remove the **lower pin** from both sides of the bottom rail (Figure 120).

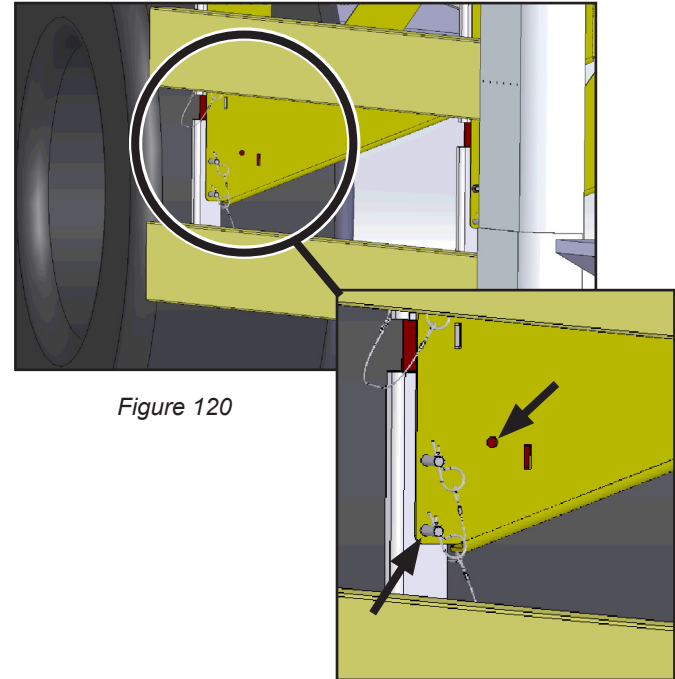

Figure 120

Operation

2. Rotate the bottom rail assembly up until the open holes on the LPD rail and the LPD gusset align (Figure 120).
3. Install each lower pin through the open holes in each bottom rail and gusset (Figure 121).

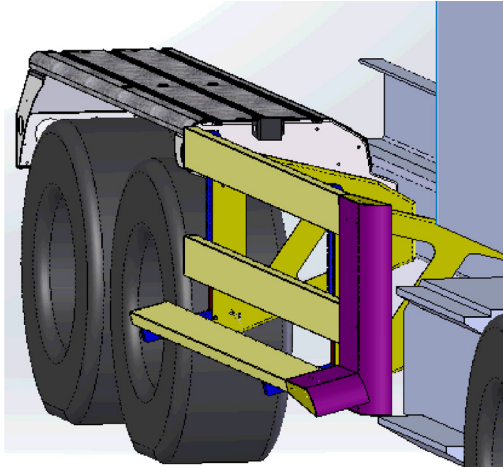





Figure 121

4. Reverse all steps to return the LPD to its original position before leaving the job site.

11.11 Preco for INSIGHT System





The optional integrated Preco radar system will only work with INSIGHT controlled Mixer systems. Refer to the Preco manual that came with the Mixer vehicle or visit Preco.com for a product manual (Side Defender or Sentry systems). The following images describe the screens that will display on the INSIGHT display system when the Preco radar system is installed and operational. A stand-alone version (not integrated) is also available. Visit Preco.com for a product manual and more information.

Vehicle Command	Image on INSIGHT Display
Vehicle is placed in reverse and vehicle is approaching an object.	

Vehicle Command	Image on INSIGHT Display
Vehicle is placed in forward drive and vehicle is approaching an object.	
Vehicle left turn signal is activated and object is detected on the left.	
Vehicle right turn signal is activated and object is detected on the right.	

Vehicle Command	Image on INSIGHT Display
Proximity of vehicle to an object (front and rear object detection). NOTE: This is not a screen on the INSIGHT display, but a legend to the color patterns shown when an object is detected.	<p>No object detected</p>  <p>Object extremely close</p>

Operation

Vehicle Command	Image on INSIGHT Display
<p>If a Preco sensor failed (missing or an error), a screen will display on the INSIGHT control display system with the failure condition.</p>	 <p data-bbox="521 386 678 410">Missing Sensor</p>  <p data-bbox="472 513 584 535">Front/Rear</p>  <p data-bbox="672 513 716 535">Side</p> <p data-bbox="537 564 675 586">Sensor Error</p>  <p data-bbox="477 689 587 710">Front/Rear</p>  <p data-bbox="672 689 716 710">Side</p>

11.12 Concrete Slump Meter

NOTE

The location of the concrete slump meter may vary.

The concrete slump meter (Figure 122, Item 1) indicates the slump of the concrete by reading the hydraulic pressure required to rotate the drum. This pressure remains reasonably constant for a wide range of load sizes, the only requirement being that the mixing blades be fully covered.

The hydraulic pressure required to rotate the drum at a specific slump will vary because of different drum size, age, and drive ratios. This requires the slump meter to be calibrated for each Mixer.

NOTE

The concrete should be thoroughly mixed before a slump reading is taken from the slump meter.

The slump meter is calibrated by positioning pointers (Figure 122, Item 2) that are marked in inches of slump around the circumference of the hydraulic gauge. The pointers indicate the pressure that is required to rotate the drum at a given slump. (See Setting the Mechanical Concrete Slump Meter.)

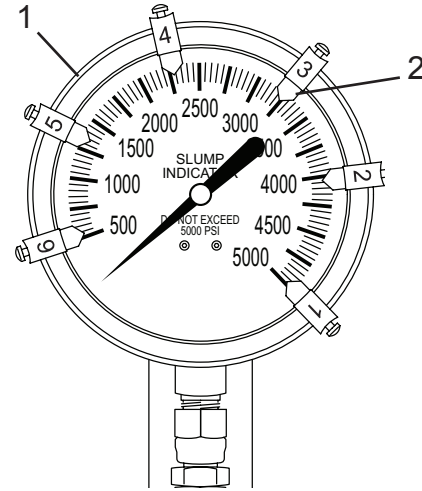

Figure 122

Operation

11.12.1 Setting the Mechanical Concrete Slump Meter

To calibrate the slump meter:

1. Load the drum with the normal full load of concrete at a slump that is less than the driest point you wish to read on your indicator, for example, 3”.

NOTE

To accurately calibrate the slump meter, the concrete must mix for at least 40 revolutions before setting the pointer.

2. Add water to the concrete until a slump reading of 3” is obtained when the concrete is fully mixed. Check the slump using a standard slump cone test.
3. Run the Mixer in the CHARGE direction with the truck engine at idle RPM. The drum must be mixing when reading the indicator.
4. Loosen the locking screw (Figure 123, Item 1), and move the 3” indicator (Figure 123, Item 2) to match the tip of the indicator needle. Tighten the locking screw.
5. Add water and test for 4”, 5”, and 6” of slump in the same manner.

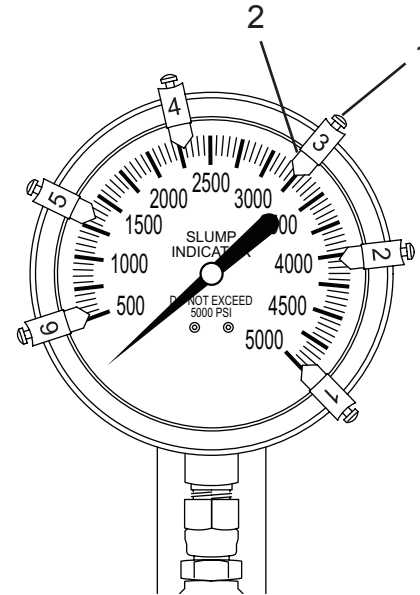

Figure 123

11.12.2 Setting the Digital Concrete Slump Meter for INSIGHT System Only

Digital slump meter must be calibrated individually on each truck upon delivery and periodically thereafter. The Slump Calibration screen is used to load and save slump calibrations. These values are then used for the inch readouts for the Slump gauges on the Drum and Slump screens.

1. Touch the Slump Calibration icon to enter the Slump Calibration screen (Figure 124).
2. Touch the “Inches” (Figure 125, Item 1) or “PSI” (Figure 125, Item 2) text box to bring up the on-screen keyboard to enter in and change the value.
3. Touch in the “profileName1” text box to name the profile that is to be saved.
4. Press the “Save” button to save the profile.
5. Follow the prompts on the screen to navigate to the next box and save the profile.

NOTE: If you enter an incorrect value in the text box, the box will turn red to signal the value needs to be changed.

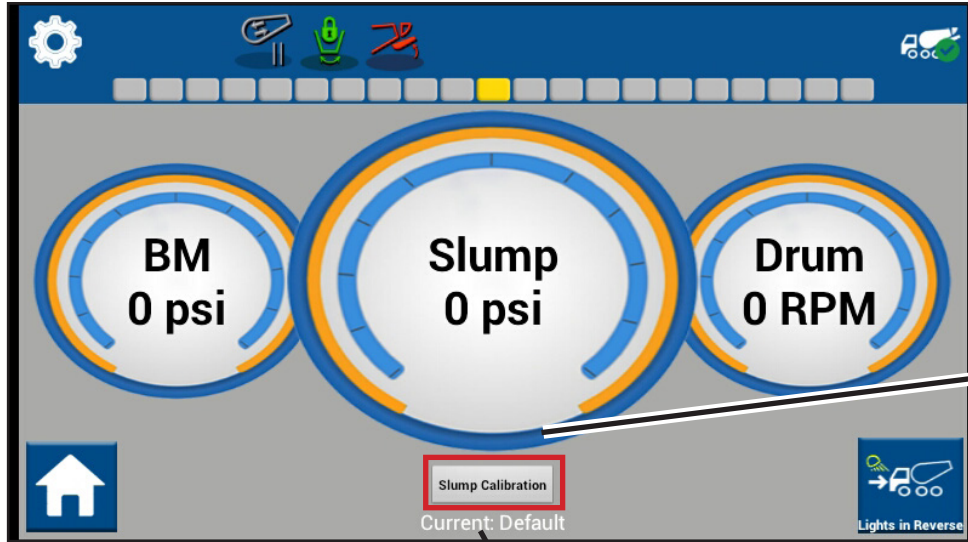

Press to Navigate to Slump Calibration Screen

Slump Calibration
Current: Default

Displays Currently Selected Slump Profile

Figure 124

11.12.2.1 Loading a Slump Calibration Profile

1. Enter the Slump Calibration screen (Figure 125).
2. Touch the drop down menu and select the desired profile to be loaded.
3. Press the “Load” button to load the desired profile.

NOTE: The text boxes on this screen will update accordingly and the current Slump Profile name will be displayed on the Slump screen.

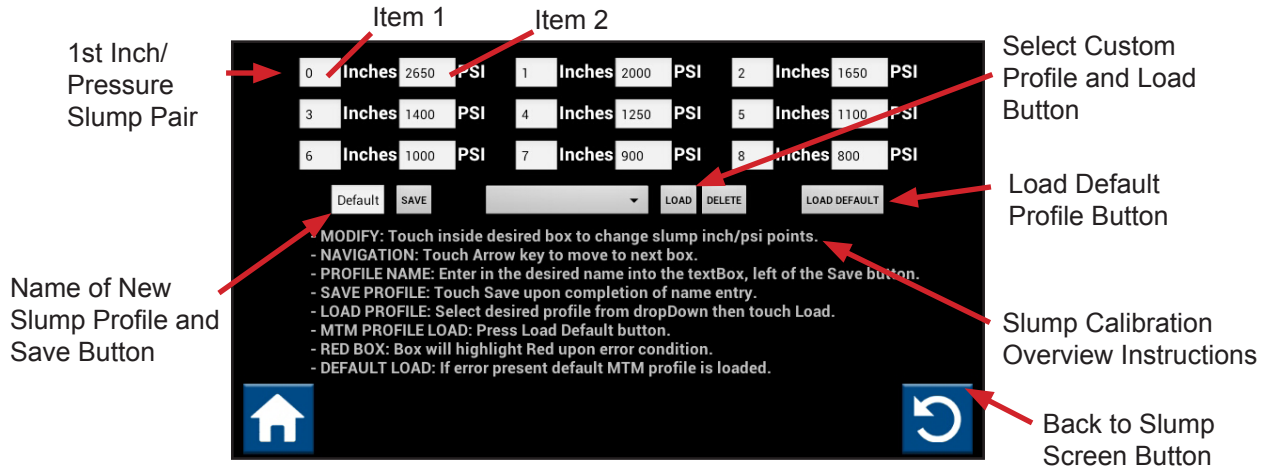

Figure 125

Operation

11.13 Central Lubrication Systems

Mixers may be equipped with one of several central lubrication systems. These systems allow mixer components to be lubricated from a central station.

Some systems have a manually-operated pump usually mounted in the cab.

NOTE

Lincoln Quicklube® system shown; other systems are similar.

Other central lubrication systems consist of a powered pump and reservoir unit (Figure 126, Item 1) mounted in the rear pedestal. This system can be set to automatically lubricate mixer components at pre-determined intervals.

Each lubrication system has unique features and operating controls. Refer to the information supplied with the Mixer for specific operating, maintenance, and troubleshooting information.

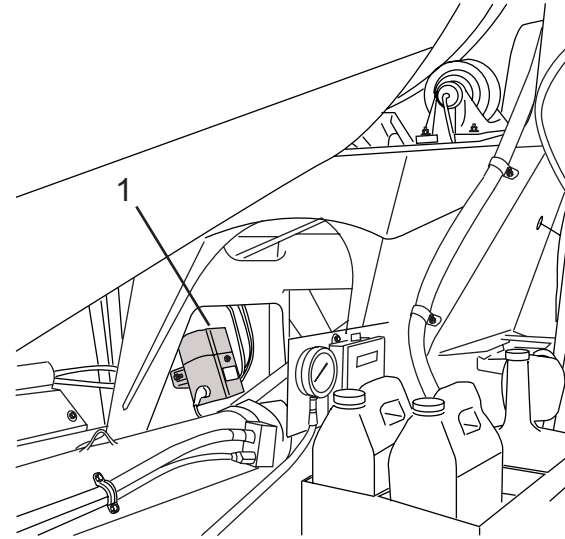

Figure 126

NOTE

The mounting location for the central lubrication system may vary depending on option and truck configuration.

The central lubrication may be equipped with an indicator light (Figure 127, Item 1). This light can be used to indicate operation and troubleshooting codes. Refer to the information supplied with the Mixer for specific information.

Each lubrication system has unique features and operating controls. Refer to the information supplied with the Mixer for specific operating, maintenance, and troubleshooting information.

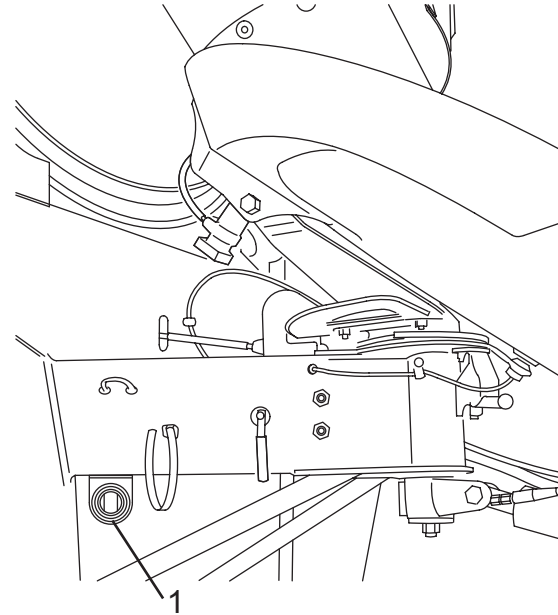

Figure 127

Operation

11.14 Wireless Remote Control (Optional)

The Wireless Remote Control system consists of a transmitter, and a receiver that is connected to the mixer electronic control system.

11.14.1 Wireless Remote Control (Cab Console Version)

The transmitter (Figure 128, Item 1) when not in use is stored in the docking cradle (Figure 128, Item 2). The cradle will automatically charge the transmitter whenever the transmitter is placed in the cradle.

The transmitter is equipped with a battery-saving feature. If the transmitter is inactive for ten minutes, the transmitter will shut itself off (the receiver will then also shut off all outputs). Pressing any of the buttons momentarily before shut-down will reset the ten-minute timer.

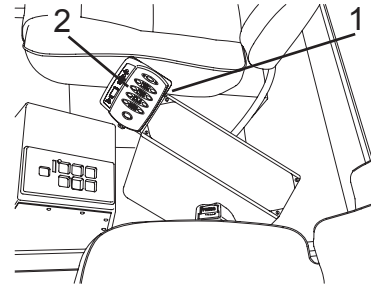

Figure 128

11.14.1.1 Control Buttons and Switches For INSIGHT System

Mixer functions can be operated by the control buttons on the transmitter and docking cradle (Figure 129), as well as the switches on the cab control console.

No.	Control	Normal Use or Reading
1	Power ON Button	Press to turn the system ON. ²
2	HOPPER UP/ DOWN Button	Press to raise or lower the charge hopper. ³
3	CHUTE LOCK/ UNLOCK Button	Press to engage the chute lock. Press the button again to disengage the chute lock.
4	CHUTE UP Button	Press and hold to raise the discharge chute.
5	CHUTE DOWN Button	Press and hold to lower the discharge chute.
6	E-STOP	
7	Power OFF Button	Press to turn the system OFF
8	DRUM PAUSE Button	Press to stop drum rotation.

No.	Control	Normal Use or Reading
9	DRUM DISCHARGE Button ¹	Press and hold to drive the drum in the DISCHARGE (CCW) direction. Continue holding the button to increase drum speed. Release the button when the desired (or maximum) speed is obtained. The button can also be pressed and released to incrementally increase speed.
10	DRUM CHARGE Button	Press and hold to drive the drum in the CHARGE (CW) direction. Continue holding the button to increase drum speed. Release the button when the desired (or maximum) speed is obtained. The button can also be pressed and released to incrementally increase speed.

Operation

No.	Control	Normal Use or Reading
11	THROTTLE RETARD Button	Press to retard throttle/drum speed. (See Adjusting the Throttle Speed for more information.)
12	THROTTLE ADVANCE Button	Press to advance throttle/drum speed. (See Adjusting the Throttle Speed for more information.)

¹ If the DRUM DISCHARGE button is pressed while the drum is rotating in the Charge direction, the drum will slow before rotating in the Discharge direction.

² The chassis cruise control must be in the ON position, the parking brake must be applied, and the automatic transmission must be in NEUTRAL.

³ The function triggered by the switch will depend on the current state of that function. (Example: If the charge hopper is up, activating the switch will lower it.)

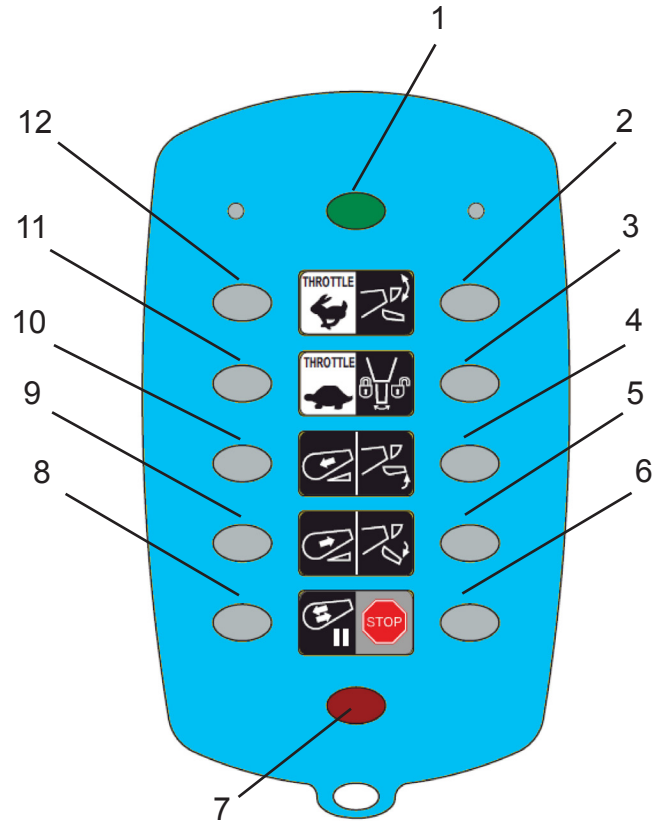

Figure 129

11.14.1.2 LED Indicators

The Battery Low (Figure 130, Item 1) and Active (Figure 130, Item 2) LED indicators on the transmitter are used to indicate the status of the transmitter.

Both of the LED indicators can display one of three colors (red, green, or yellow), and may operate in a solid, or in slow-flash or fast-flash display modes.

The combination of indicators activated, colors, and display modes are used to display transmitter status or display the fault code. (See Diagnostic Codes - Transmitter.)

No.	Control	Normal Use or Reading
3	BATTERY	The indicator is ON when the transmitter is installed in the docking cradle to indicate that the batteries are being recharged.

No.	Control	Normal Use or Reading
1	BATTERY LOW LED	The indicator is ON when the batteries are low. The LED is also used to display diagnostic codes.
2	ACTIVE LED	The LED indicates that there is activity between the transmitter and receiver. The LED is also used to display diagnostic codes.

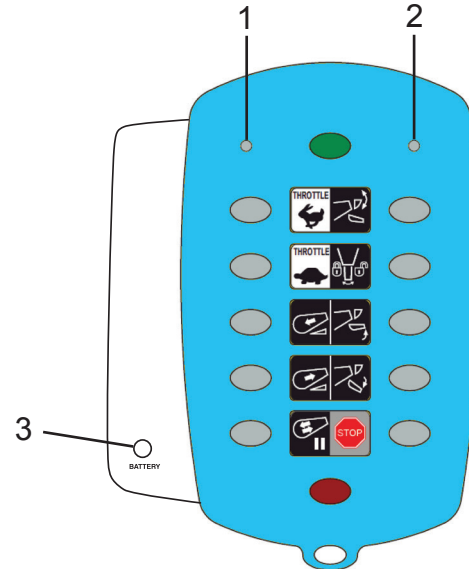

Figure 130

Operation

11.14.1.3 Control Buttons and Switches For Traditional Controls

NOTE

Transmitter buttons 4, 5, and 10 have alternate functions. The alternate functions are accessed by pressing and holding the green power button after the system is turned on.

Mixer functions can be operated by the control buttons on the transmitter and docking cradle (Figure 131), as well as the buttons on the cab control console.

No.	Control	Normal Use or Reading
1	DRUM CHARGE Button ⁵	Press and hold to drive the drum in the CHARGE (CW) direction. Continue holding the button to increase drum speed. Release the button when the desired (or maximum) speed is obtained. The button can also be pressed and released to incrementally increase speed.

No.	Control	Normal Use or Reading
2	Power ON Button	Press to turn the system ON.
	SHIFT SELECT Button (Press and Hold)	Once the system has been activated, pressing and holding the button allows buttons 4, 5, and 10 to operate in the alternate function (lower icon).
3	DRUM DISCHARGE Button ^{1 and 5}	Press and hold to drive the drum in the DISCHARGE (CCW) direction. Continue holding the button to increase drum speed. Release the button when the desired (or maximum) speed is obtained. The button can also be pressed and released to incrementally increase speed.

No.	Control	Normal Use or Reading
4	THROTTLE RETARD Button ² (Primary Function)	Press to retard throttle/drum speed. (See “Adjusting the Throttle Speed” for more information.)
	HOPPER UP/DOWN Button ³ (Alternate Function)	Press to raise or lower the charge hopper. ⁴
5	CHUTE DOWN Button (Primary Function)	Press and hold to lower the discharge chute.
	CHUTE SWING (RIGHT) Button ² (Alternate Function)	Press and hold to swing the discharge chute to the right.
6	CHUTE LOCK/UNLOCK Button	Press to engage the chute lock. ³ Press the button again to disengage the chute lock.
7	Power OFF Button	Press to turn the system OFF. The drum will stop if it was rotating when the button was pressed.

No.	Control	Normal Use or Reading
8	DRUM STOP Button	Press to stop drum rotation. ³
9	CHARGE/DISCHARGE Button (Located on Docking Cradle) ⁵	Press the CHARGE side of the switch to activate the drum rotation in CHARGE (CW) direction. Holding the switch down also increases drum speed in CHARGE (CW) direction or decreases drum speed in DISCHARGE (CCW) direction. Press the DISCHARGE side of the switch to activate the drum rotation in DISCHARGE (CCW) direction. Holding the switch down also increases drum speed in DISCHARGE (CCW) direction or decreases drum speed in charge (CW) direction

Operation

No.	Control	Normal Use or Reading
10	CHUTE UP Button (Primary Function)	Press and hold to raise the discharge chute.
	CHUTE SWING (LEFT) Button (Alternate Function) ²	Press and hold to swing the discharge chute to the left.
11	THROTTLE ADVANCE Button	Press to advance throttle/drum speed. (See “Adjusting the Throttle Speed” for more information.)

¹ If the DRUM DISCHARGE button is pressed while the drum is rotating in the Charge direction, the drum will slow before rotating in the Discharge direction.

² The chassis cruise control must be in the ON position, the parking brake must be applied, and the automatic transmission must be in NEUTRAL.

³ To activate the alternate function, press and hold the Power ON/SHIFT SELECT button.

⁴ The function triggered by the switch will depend on the current state of that function. (Example: If the charge hopper is up, activating the switch will lower it.)

⁵ Mixers with Cable Control will not have this function.

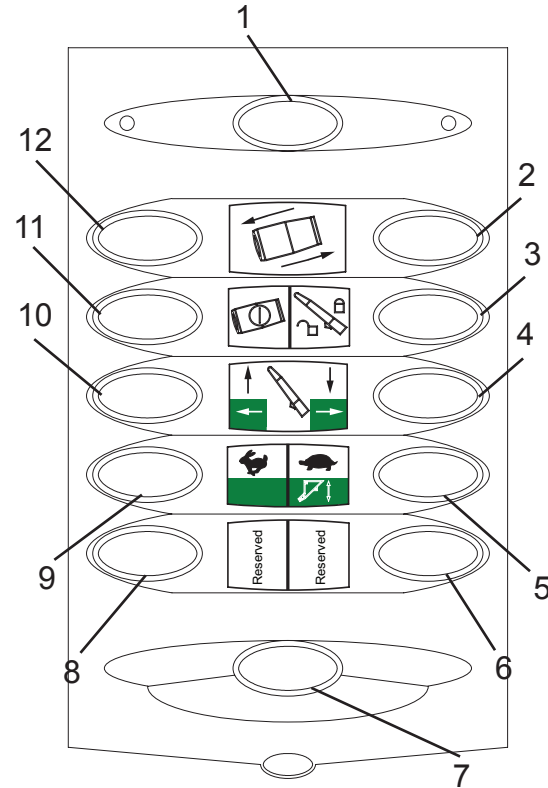

Figure 131

11.14.1.4 LED Indicators

The Battery Low (Figure 132, Item 1) and Active (Figure 132, Item 2) LED indicators on the transmitter are used to indicate the status of the transmitter.

Both of the LED indicators can display one of three colors (red, green, or yellow), and may operate in a solid, or in slow-flash or fast-flash display mode.

The combination of indicators activated, colors, and display modes are used to display transmitter status or display the fault code. (See Diagnostic Codes - Transmitter.)

No.	Control	Normal Use or Reading
1	Battery Low LED	The indicator is ON when the batteries are low. The LED is also used to display diagnostic codes.
2	Active LED	The LED indicates that there is activity between the transmitter and receiver. The LED is also used to display diagnostic codes.

No.	Control	Normal Use or Reading
3	BATTERY	The indicator is ON when the transmitter is installed in the docking cradle to indicate that the batteries are being recharged.
4	DRUM STOP	The indicator is ON when the drum rotation is stopped.
5	CHUTE UNLOCKED	The light indicates that the chute lock is unlocked.
6	HOPPER UP	The light indicates that the hopper is in the UP position.

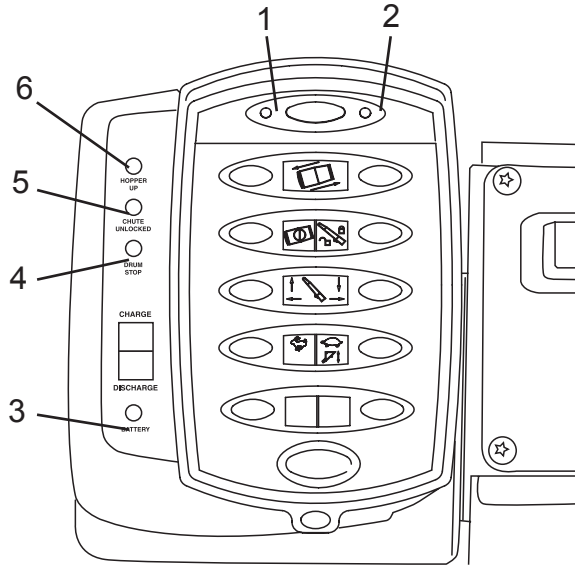

Figure 132

11.14.2 Cleaning the Transmitter

CAUTION

Do not clean the transmitter or receiver using high pressure.

If water or other liquids get inside the transmitter battery compartment or receiver, immediately dry the unit. Remove the case and allow it to air dry before use.

Failure to comply may result in damage to equipment.

Use a damp cloth to clean the transmitter unit after operation. Remove mud, dirt, concrete, etc. from the transmitter to prevent clogging of buttons.

11.14.3 Wireless Remote Control Troubleshooting

11.14.3.1 Diagnostic Codes – Transmitter

1. The Battery Low (Figure 133, Item 1) and Active (Figure 133, Item 2) LED indicators on the transmitter are used to indicate the status of the transmitter (transmitter for Traditional Controls used for illustrative purposes).

2. Both of the LED indicators can display one of three colors (red, green, or yellow), and may operate in a solid, or in slow-flash or fast-flash display modes.
3. The combination of indicators activated, colors, and display modes are used to display transmitter status or display the fault code.

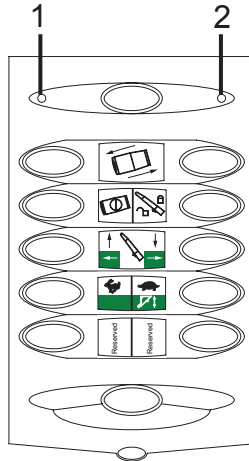

Figure 133

LED Indicator Activity	Status/Fault	Action
Battery Low LED: OFF Active LED: ON – Solid	Occurs whenever a function is pressed. Will also remain on momentarily during power-up.	None required – Normal operation.
Battery Low LED: OFF Active LED: ON – Slow Flash	Transmitter is in download mode.	Turn transmitter OFF and back ON again.
Battery Low LED: OFF Active LED: ON – Fast Flash	Transmitter is in operating mode.	None required – Normal operation.
Battery Low LED: ON – Slow Flash Active LED: ON – Fast Flash	Low battery.	Replace batteries. (See Battery Replacement– Plug and Play Version.) Recharge batteries by placing the transmitter in the docking cradle (cab control box version).
Battery Low LED: ON – Fast Flash (10 seconds) Active LED: OFF	Transmitter failure.	Requires shop service and repair.
Battery Low LED: ON – Slow Flash Active LED: ON – Slow Flash	Stuck button detected.	Turn power off. Depress all buttons several times to free the stuck button. Turn power on and check button functions. If problem cannot be cleared, shop service is required.

LED Indicator Activity	Status/Fault	Action
On Power Down – Only: Battery Low LED: ON – Slow Flash Active LED: ON – Slow Flash	Unit still under power; a stuck button may be detected.	Turn power off. Depress all buttons several times to free the stuck button. Turn power on and check button functions. If a problem cannot be cleared, shop service is required.
Battery Low LED: ON – Fast Flash Active LED: ON – Fast Flash	Transmitter is in configuration mode.	Requires shop service and repair.
Battery Low LED: ON – Solid Active LED: ON – Solid	Transmitter is downloading ID code.	Requires shop service and repair.

Operation

11.14.4 Receiver Locations

If the Mixer does not respond to commands from the transmitter, the receiver may need to be accessed to check diagnostic codes.

Depending on the version of the wireless remote installed, the location of the receiver will vary.

Cab Control Box Version: The receiver is located in the control box (cab control box) (Figure 134, Item 1).

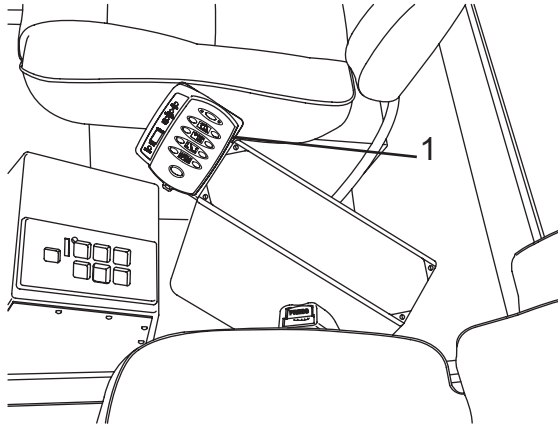

Figure 134

11.14.4.1 LED Indicators

LED indicators (Figure 135, Item 1) are used to indicate the operational status of the receiver. The LED indicators are also used to diagnose transmitter problems.

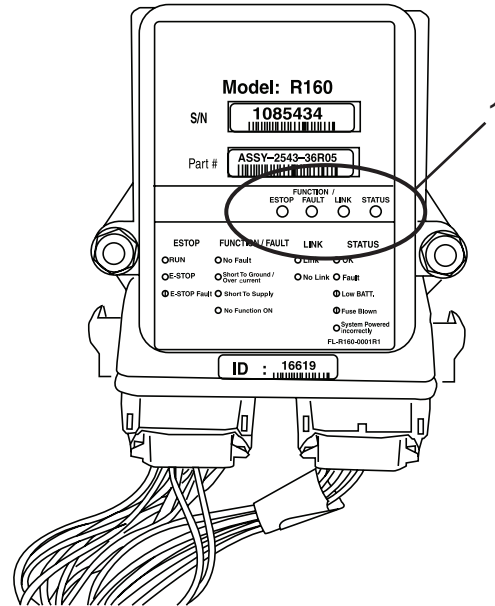

Figure 135

11.14.4.2 Normal Operation

LED Indicator Activity	Transmitter Status	Receiver Status
E-STOP: ON – Solid Red FAULT: OFF LINK: ON – Solid Red STATUS: ON – Solid Green	Transmitter: OFF	The receiver is operating properly.
E-STOP: ON – Solid Green FAULT: OFF LINK: ON – Green – Fast Flash STATUS: ON – Solid Green	Transmitter: ON	The receiver is operating properly.
E-STOP: ON – Solid Green FAULT: ON – Solid Green LINK: ON – Green – Fast Flash STATUS: ON – Solid Green	Transmitter: In operation	The receiver is operating properly.
E-STOP: ON – Solid Red FAULT: ON – Solid Green LINK: ON – Solid Red STATUS: ON – Solid Green	Transmitter: OFF	When a latched function is activated when the transmitter is turned off, the FAULT light will stay green. The receiver is operating properly. If the FAULT light is not green, service is required.

Operation

11.14.4.3 Fault Codes

NOTE: In some cases, the LED indicators will vary, depending on whether the transmitter is ON or OFF. See the transmitter status in the “Status/Fault” column in the chart in the pages below.

LED indicators (Figure 136, Item 1) are used to display the receiver fault codes.

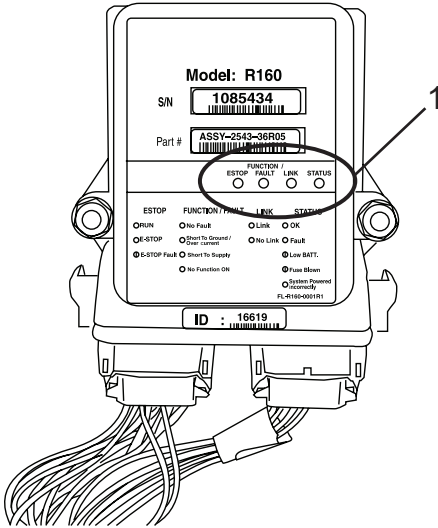

Figure 136

LED Indicator Activity	Status/Fault	Action
E-STOP: ON – Solid Red FAULT: OFF LINK: ON – Solid Red STATUS: ON – Solid Green	Transmitter: ON Receiver is not receiving a signal from the transmitter	Transmitter does not match receiver. Use correct transmitter. If transmitter matches receiver, the receiver requires shop service and repair.
E-STOP: ON – Solid Green FAULT: OFF LINK: ON – Green – Fast Flash STATUS: ON – Green – Slow Flash	Transmitter: ON A low battery condition has been detected	Replace batteries (Plug and Play Version). (See Battery Replacement – Plug and Play Version.) Recharge batteries (cab control box version). If fault code still displays after the batteries have been replaced, shop service and repair is required.
E-STOP: ON – Red – Slow Flash FAULT: OFF LINK: ON – Green – Fast Flash STATUS: ON – Solid Red	Transmitter: ON Short detected in E-STOP circuit	Requires shop service and repair.
E-STOP: ON – Solid Green FAULT: ON – Solid Red LINK: ON – Green – Fast Flash STATUS: ON – Solid Red	Transmitter: ON A short to ground or excessive current load has been detected	Requires shop service and repair.

LED Indicator Activity	Status/Fault	Action
E-STOP: ON – Solid Red FAULT: ON – Red – Slow Flash LINK: ON – Red – Fast Flash STATUS: ON – Solid Red	Transmitter: ON E-STOP output not properly connected	Requires shop service and repair.
E-STOP: ON – Solid Red FAULT: ON – Red – Slow Flash LINK: ON – Solid Red STATUS: ON – Solid Red	Transmitter: OFF A wiring short to the battery has been detected	Requires shop service and repair.
E-STOP: ON – Solid Red FAULT: OFF LINK: ON – Solid Red STATUS: ON – Solid Red	Transmitter: OFF Internal fault detected in receiver	Requires shop service and repair
E-STOP: ON – Solid Red FAULT: OFF LINK: ON – Solid Red STATUS: ON – Red – Slow Flash	Transmitter: OFF Blown fuse detected	Replace fuse. (See Fuse Functions.)
E-STOP: ON – Solid Green FAULT: OFF LINK: ON – Red – Fast Flash STATUS: ON – Red – Fast Flash	Transmitter: ON Set-up mode failure	Requires shop service and repair

LED Indicator Activity	Status/Fault	Action
E-STOP: ON – Solid Red FAULT: ON – Red – Slow Flash LINK: ON – Solid Red STATUS: ON – Alternating Red/ Green – Fast Flash	Transmitter: OFF Receiver powered incorrectly	Requires shop service and repair

12.0 Chassis Options

12.1 Pusher and Tag Axles

The auxiliary axle down force is controlled by regulated air pressure to the axle suspension air springs. The regulated air pressure is preset at the factory to a common pressure setting. Determine the actual regulated air pressure by driving the vehicle over a truck scale at the various weights the vehicle will be operated at up to the GVWR as shown on the Final Stage Manufacturer Label located on the driver's side cab doorjamb (see the Foreword). Adjust the regulated air pressure according to the auxiliary axle manufacturer's pressure/weight chart located in the cab information packet supplied with the vehicle. The air pressure gauge is located in the cab of the vehicle and may also be located outside of the cab.

Always follow your company's policies and procedures when adjusting the air pressure. If you have any questions, call Revolution Parts and Support at (855) 202-6491.

NOTE

The following information is for auxiliary axles installed by Revolution Concrete Mixers. Refer to chassis manufacturer information for axles installed by the chassis manufacturer or a third party.

Pusher axle(s) (Figure 137, Item 1) are located in front of the rear drive axle. Tag axles are located at the rear of the truck (not shown).

Auxiliary axles use UP/DOWN buttons (labeled PUSHER) to control the lower and lift function. The UP/DOWN buttons are located on the digital control display in the cab (Figure 138).

The auxiliary axle down force is controlled by regulated air pressure to the axle suspension air bags. The regulated air pressure is preset at the factory. The air pressure of the axle is displayed on an air gauge located in the truck cab. The air gauge may also be mounted outside of the cab.

To change the air pressure of an auxiliary axle, refer to the service manuals for your truck. Always follow your company's policies and procedures when adjusting the air pressure. If you have any questions, call Revolution Parts and Support at (855) 202-6491.

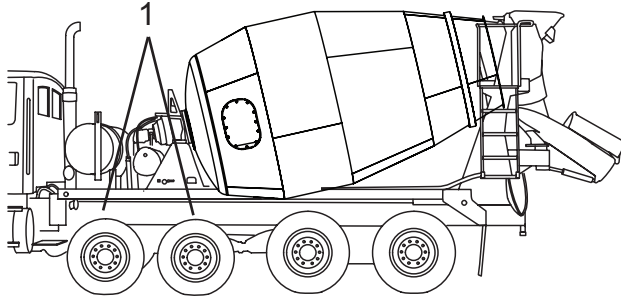

Figure 137

12.1.1 Raising or Lowering Pusher Axle for INSIGHT Mixer System

NOTE

Lower the auxiliary axles only when your load requires an auxiliary axle to distribute load weight. **NEVER** lower auxiliary axles when the truck is moving, or when the mixer is empty. The pusher axle air pressure is preset at the factory. Only your service department is authorized to adjust air pressure.

Revolution installed pusher axles are designed to lift when the truck is placed in reverse.

NOTE: Auxiliary axles may raise when the truck is placed in reverse.

1. Bring the truck to a complete stop and set the park brake. (Refer to the Operator's Manual supplied by the chassis supplier for all parking procedures.)
2. Press the Pusher Axle function button (UP button is Item 1, and DOWN button is Item 2) on the standard in-cab keypad (Figure 138).

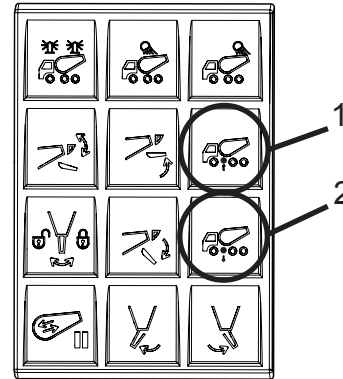

Figure 138

Operation

12.1.2 Raising or Lowering Tag Axle for INSIGHT System

NOTE: Auxiliary axles may raise when the truck is placed in reverse.

1. Bring the truck to a complete stop and set the park brake. (Refer to the Operator's Manual supplied by the chassis supplier for all parking procedures.)
2. Press the Tag Axle function button (UP button is Item 1, and DOWN button is Item 2) on the optional in-cab keypad (Figure 139).

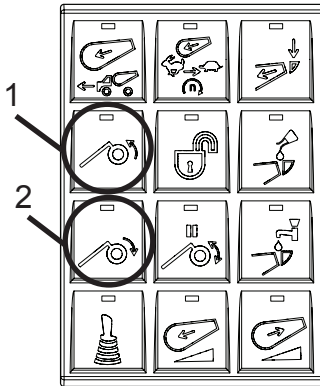

Figure 139

12.1.3 Lowering Pusher or Tag Axle for Traditional Controls Only

NOTE: Auxiliary axles may raise when the truck is placed in reverse.

NOTE

Lower the auxiliary axles only when your load requires an auxiliary axle to distribute load weight. NEVER lower auxiliary axles when the truck is moving, or when the mixer is empty. The pusher axle air pressure is preset at the factory. Only your service department is authorized to adjust air pressure.

Revolution installed pusher axles are designed to lift when the truck is placed in reverse.

1. Bring the truck to a complete stop and set the park break. (Refer to the Operator Manual supplied by the chassis supplier for all parking procedures.)
2. Push the pusher axle or the tag axle UP/DOWN switch to the DOWN position.
3. Resume normal operation.

12.1.4 Raising Pusher or Tag Axle for Traditional Controls Only

NOTE

Revolution installed pusher axles are designed to lift when the truck is placed in reverse.
--

1. Bring the truck to a complete stop and set the park brake. (Refer to the Operator's Manual supplied by the chassis supplier for all parking procedures.)
2. Push the pusher axle or tag axle UP/DOWN switch to the UP position.
3. Resume normal operation.

1.0 Preventive Maintenance

The unit must be checked or inspected each day or before each new shift of operation. Report any deficiencies to your Maintenance Department for correction by skilled service personnel.



 **CAUTION**

Correct all identified deficiencies BEFORE operating the mixer. Failure to comply may cause damage to property or equipment.

1.1 DOT Pre-Trip

Perform pre-trip inspection of chassis and Mixer according to all federal, state, and local laws.

2.0 Preventive Maintenance Intervals

Performing preventive maintenance on your Mixer will prolong the life of its equipment, help prevent expensive downtime, and minimize the potential for problems arising during use.

The following Preventive Maintenance Chart summarizes the requirements to properly maintain your Mixer.

The chart specifies the recommended interval when each item should be performed.

Intervals are listed in calendar and hours-of-use increments. Maintenance should be performed at the increment that occurs first.

The preventive maintenance intervals listed under the **Service** group heading are the maximum days or hours allowed for each maintenance procedure. Continue to repeat the maintenance procedures at the listed intervals.

The Preventive Maintenance Chart identifies the responsibilities to be performed by both the operator and service personnel.

Preventive Maintenance

Some maintenance procedures are listed under both the **Operator** group heading and **Service** group heading.

The Daily Checks under the **Operator** group heading identify procedures that can be performed by either the operator or skilled service personnel.

NOTE

If the mixer is operated more hours per day or double-shifted, the maintenance interval must be adjusted accordingly.

The Preventive Maintenance Chart identifies the responsibilities to be performed by both the operator and service personnel.

Some maintenance procedures are listed under both the **Operator** group heading and Service group heading.

The Daily Checks under the **Operator** group heading identify procedures that can be performed by either the operator or skilled service personnel.

All intervals listed under the **Service** group heading must be performed by skilled service personnel. Refer to the product Service Manual for description of maintenance procedures.

Maintenance procedures are listed under the system of the Mixer that is affected.

LEGEND

R Replace **P** Perform
I Inspect **L** Lubricate
T Torque **C** Clean

	Number of Fittings	Operator				Service			
		Daily Checks	Daily (10 Hours)	Weekly (50 Hours)	After First (100 Hours)	Monthly (200 Hours)	Semi-Annually (1250 Hours)	Annually (2500 Hours)	

Lubrication - NLGI Grade 2 General Purpose EP Grease									
Drum Roller Bearings	2	L	L						
Remote Lubrication System	2	L	L						
Drum Roller Track (Brush On)	—	I	I						
PTO Shaft – Slip Joint	1			L					
PTO Shaft – U-Joints	2			L					
Main Chute Pivot	1			L					
Main Chute Pivot - Remove Lubrication System	1			L					
Main Chute Manual Lock Shaft	—			L					
Drum Control Lever	2			L					
Hydraulic System									
Oil Level – Sight Glass		I/P	I/P						

Preventive Maintenance



LEGEND

- R** Replace **P** Perform
I Inspect **L** Lubricate
T Torque **C** Clean

	Operator				Service			
	Number of Fittings	Daily Checks	Daily (10 Hours)	Weekly (50 Hours)	After First (100 Hours)	Monthly (200 Hours)	Semi-Annually (1250 Hours)	Annually (2500 Hours)
Hydraulic Oil For Ambient Temps < 80°F (27°C) Use ISO Grade 68 For Ambient Temps > 80°F (27°C) Use ISO Grade 100					R		R	
Suction Filter (Rating B10 = 2) (50% efficient at 10 microns) Hydraulic oil at operating temperature: 2 to 5 in-hg, never read more than 10 in-hg					R		R	
Suction Filter – Gate Valve Valve Open (A cable tie must be installed on the valve handle to prevent inadvertent closing of the valve)		I/P	I/P					
Hydraulic System and Components		I			I			
Hydraulic Hoses		I						
Hydraulic Pipes/Tubes		I						
ZF Gearbox								
Oil Level – Sight Glass		I/P	I/P					

LEGEND

- R** Replace **P** Perform
I Inspect **L** Lubricate
T Torque **C** Clean

	Number of Fittings	Daily Checks	Operator	Daily (10 Hours)	Weekly (50 Hours)	After First (100 Hours)	Monthly (200 Hours)	Service	Semi-Annually (1250 Hours)	Annually (2500 Hours)
Lubricant GL5 Spec. 85W-140 Gear Oil Capacity 4.2 gallons, 17 quarts (16.1 liters) Remove dipstick from oil fill port <div style="background-color: #f4a460; padding: 2px; text-align: center;">⚠ WARNING</div> Pressurized oil may blow out of port when opened. Keep face and body away from port. Serious injury or death may occur.									R	R
CML 12 Gearbox										
Oil Level – Sight Glass*		I/P	I/P							
Lubricant GL5 Spec. 85W-140 Gear Oil Capacity 4.2 gallons, 17 quarts (16.1 liters) Remove dipstick from oil fill port <div style="background-color: #f4a460; padding: 2px; text-align: center;">⚠ WARNING</div> Pressurized oil may blow out of port when opened. Keep face and body away from port. Serious injury or death may occur.								I*		

Preventive Maintenance



LEGEND

- R Replace P Perform
- I Inspect L Lubricate
- T Torque C Clean

	Operator			Service				
	Number of Fittings	Daily Checks	Daily (10 Hours)	Weekly (50 Hours)	After First (100 Hours)	Monthly (200 Hours)	Semi-Annually (1250 Hours)	Annually (2500 Hours)

* The lubrication level of the CML 12 gearbox should be checked monthly, but an oil change is not required throughout the normal service life. However, it is recommended to change the oil after 10,000 hours or 6 years.

Pneumatic System

Coalescing Filter		P	P			I/R		
Air Hoses and Fittings		I			I			

Standard Steel Drum

Drum Inspection						I		
-----------------	--	--	--	--	--	---	--	--

Mechanical System

Mixer Body and Components		I			I			
Water Tank		I						
Access Ladder(s) and Mounting Hardware		I						
Wheel Lug Nuts Tighten all lug nuts (including auxiliary axle) to 450 lb-ft (610 N•m)				T				
Chute Extensions		I						

Electrical System

LEGEND

- R** Replace **P** Perform
I Inspect **L** Lubricate
T Torque **C** Clean

	Number of Fittings	Operator			Service			
	Daily Checks	Daily (10 Hours)	Weekly (50 Hours)	After First (100 Hours)	Monthly (200 Hours)	Semi-Annually (1250 Hours)	Annually (2500 Hours)	
Lighting System		I			I			
Wire Harness		I			I			
Audible back-up alarm		I/P	I/P					
Optional Equipment								
Spray Bar Strainer (50 Mesh Strainer)				C/I ¹				
Chute Assist		I	I					
¹ Replace strainer as required.								
Operation								
Mixer Controls		P			P			
Safety Signs		I						

3.0 Preventive Maintenance Daily Checks

3.1 Hydraulic System

SAFETY NOTICE

Perform your company's Lockout/Tagout procedure. If your company does not have a Lockout/Tagout procedure, follow OSHA 1910.147 and 1910.146 Confined Space as appropriate.

3.1.1 Hydraulic Oil Level

- **Daily Checks** – The oil level is checked by the operator or skilled service personnel.

NOTE

Check hydraulic oil level during start-up when the oil temperature is still cold.

Check the hydraulic oil level with all hydraulic components off and all hydraulic cylinders retracted.

NOTE

The shape and location of the hydraulic reservoir may vary. Round tank configuration shown. Square reservoirs may be mounted on the frame rails, in front of the radiator.

Check the hydraulic oil level at the sight gauge on the front of the reservoir. Hydraulic oil should be visible at the bottom of the sight gauge (Figure 140, Item 1).

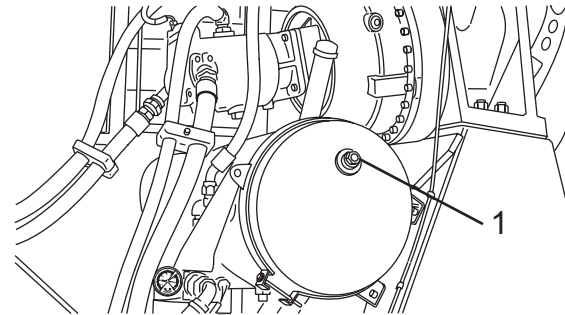

Figure 140

3.1.2 Hydraulic System and Components

- **Daily Checks** – The hydraulic system and components are inspected by the operator or skilled service personnel.

Inspect the hydraulic system and components for leaks and damage. Inspect around all fittings and connections. Look for any fresh puddles or drips under the Mixer.

Ensure that all components are securely mounted and that all bolts and nuts are in place and secure.

Inspect for cracks or other damage to the mounting brackets.

3.2 Electrical System

SAFETY NOTICE

Perform your company's Lockout/Tagout procedure. If your company does not have a Lockout/Tagout procedure, follow OSHA 1910.147 and 1910.146 Confined Space as appropriate.

3.2.1 Lighting System

- **Daily Checks** – The lighting system is inspected by the operator or skilled service personnel.

Check to ensure that all exterior lights on the Mixer and chassis are functioning correctly. Replace any burned-out bulbs with the same type.

3.2.2 Warning Alarm System

- **Daily Checks** – The warning alarm system is inspected by the operator.

Check to ensure that all audible warning alarms on the Mixer are functioning correctly. Replace any audible warning alarms with the same type.

Preventive Maintenance

3.3 Pneumatic System

SAFETY NOTICE

Perform your company's Lockout/Tagout procedure. If your company does not have a Lockout/Tagout procedure, follow OSHA 1910.147 and 1910.146 Confined Space as appropriate.

Pneumatic Lines and Fittings

- **Daily Checks** – The pneumatic lines and fittings are inspected by the operator or skilled service personnel.

Check the pneumatic lines and fittings for leaks, wear, abrasion, damage, and proper clearance. Ensure that all fittings are secure.

3.3.1 Coalescing Filter

- **Daily Checks** – The coalescing filter is drained by the operator or skilled service personnel.
1. Locate the drain fitting (Figure 141, Item 1) on the bottom of the coalescing filter.
 2. Drain the filter by turning the drain fitting counterclockwise.

3. After all moisture and contaminants have drained from the canister, turn the drain fitting clockwise.

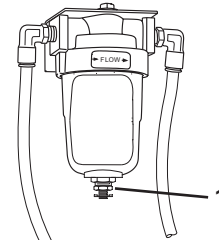

Figure 141

3.4 Mechanical System

SAFETY NOTICE

Perform your company's Lockout/Tagout procedure. If your company does not have a Lockout/Tagout procedure, follow OSHA 1910.147 and 1910.146 Confined Space as appropriate.

3.4.1 Mixer Components and Pedestals

- **Daily Checks** – The Mixer components should be inspected by the operator or skilled service personnel.

Inspect the pedestals and all components for binding, damage, and loose or missing parts.

Inspect access ladder(s) (Figure 142, Item 1) and mounting hardware for damage and/or loose or missing hardware.

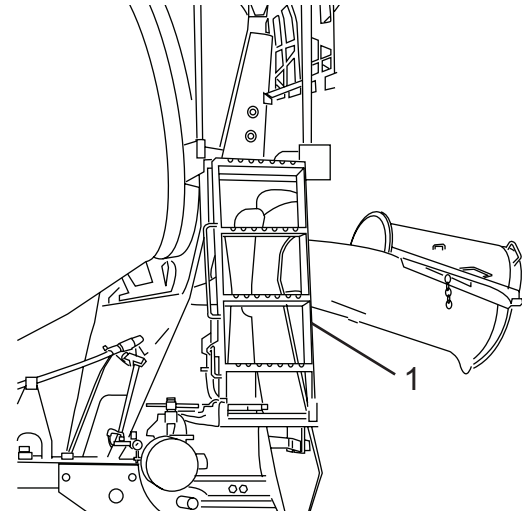

Figure 142

Preventive Maintenance

3.4.2 Water Tanks

- **Daily Checks** – The water tank(s) and components should be inspected by the operator or skilled service personnel.

CAUTION

Do not weld on or near the water tank. If the water tank requires structural repair, contact Revolution Concrete Mixers at (855) 202-6491. Attempting to repair the water tank will void your warranty. Failure to comply may cause damage to property or equipment.

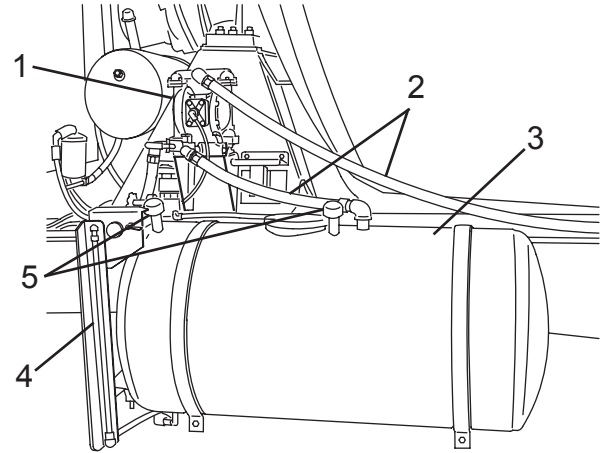

Figure 143

1. Inspect the water tank(s) (Figure 143, Item 3) for leaks, cracks, breaks, or structural damage.
2. Inspect hoses (Figure 143, Item 2) for leaks, cracks, or damage.
3. Inspect sight glass(es) (Figure 143, Item 4) for cracks or damage.
4. Check pump (Figure 143, Item 1) (if equipped) for proper operation.
5. Check breathers (Figure 143, Item 5) (if equipped) to make sure they are free of debris.
6. Check flopper valve (Figure 144, Item 1) for free movement, and make sure it seats properly.
7. Check valves (Figure 144, Items 2 and 3) to make sure they move freely.

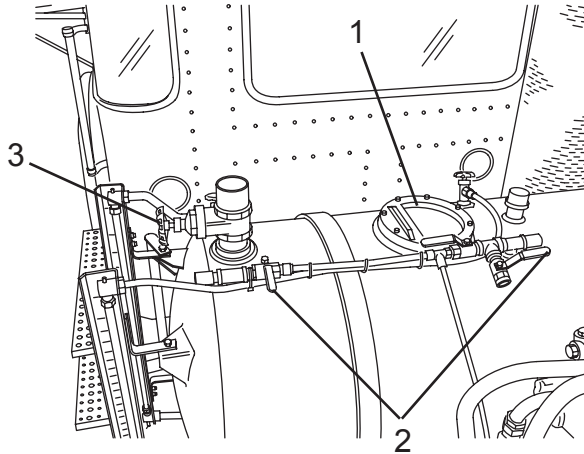

Figure 144

3.4.3 Chute Extensions

- **Daily Checks** – The chutes extensions should be inspected by the operator or skilled service personnel.

WARNING

Do not repair metal or composite chute extensions. Failure to comply may result in serious personal injury or death.

CAUTION

Never clean chute extensions by striking or chiseling. Failure to comply may cause damage to property or equipment.

DANGER

Flammable Hazard. Any urethane parts are flammable. Do not expose to an open flame or a temperature exceeding 220°F (104°C). Burning chute extensions produce toxic smoke/fumes during combustion. Failure to do so will result in serious personal injury or death.

1. Inspect the chute extensions for cracks, breaks, or structural damage. Replace chute(s) if any damage is noted.

3.4.4 Chute Assist

- **Daily Checks** – The chute assist should be inspected daily by the operator or skilled service personnel for wear, cable damage, pulley damage, and the correct tension.

WARNING

Crush Hazard. The chute assist has pinch points between the main chute and the fold-over chute. Keep hands away from chute hardware where chutes connect. Keep hands away from the pulley system. Failure to comply may result in serious personal injury or death.

WARNING

Crush Hazard. Do not stand under the chute while adjusting or testing the tension of the chute assist. Failure to comply may result in serious personal injury or death.

To adjust the tension of the chute assist:

1. Park the truck safely. (Refer to the Operator's Manual supplied by the chassis supplier for all shut-down and parking procedures.)
2. Apply the Lockout/Tagout procedure. (See Applying the Lockout/Tagout Procedure.)
3. Put the foldover chute in the down/open position.
4. Loosen the nuts on the tension rod during the adjustment (Figure 145).
5. Use a pair of vice grips or other suitable tool to hold the tension tube and turn the tension rod clockwise to increase the tension or counter-clockwise to reduce the tension (Figure 145).
6. Divide the tension adjustment between both sides of the chute assist, making the right side and left side equal.
7. Adjust the tension so when the fold-over chute is in the UP/CLOSED position, the cable is taut and does not droop or sag.
8. Once the proper tension is achieved, apply Blue Loctite® and tighten the nuts to lock the adjustment.
9. Over extension of the spring beyond 22-1/4" will damage the spring.
10. Inspect the chutes and chute assist daily for wear, cable damage, pulley damage, and the correct

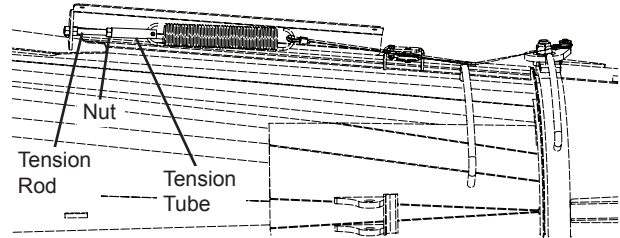

Figure 145

tension. Inspect and adjust as necessary, especially after the cables and springs stretch.

3.5 Standard (Steel) Drum

3.5.1 Standard (Steel) Drum Inspection

- **Daily Checks** – The mixer drum should be inspected by the operator or skilled service personnel.
1. Park the truck safely. (Refer to the Operator's Manual supplied by the chassis supplier for all shut-down and parking procedures.)
 2. Raise the charge hopper.
 3. Perform your company's Lockout/Tagout procedure. If your company does not have a Lockout/Tagout procedure, follow OSHA 1910.147 and 1910.146 Confined Space as appropriate.
 4. Inspect the interior of the drum for concrete build-up. Remove concrete as needed. (See Concrete Removal for removal information.)
 5. Check the discharge hopper-to-drip ring clearance (Figure 146, Item 1). Clearance should be 2 inches (51 mm) between the discharge hopper face and the drip ring, and no more than 1 inch (25 mm) radially around the drip ring.

Preventive Maintenance

6. Check the areas where the discharge hopper and drip ring meet for concrete build-up. Remove concrete as needed.

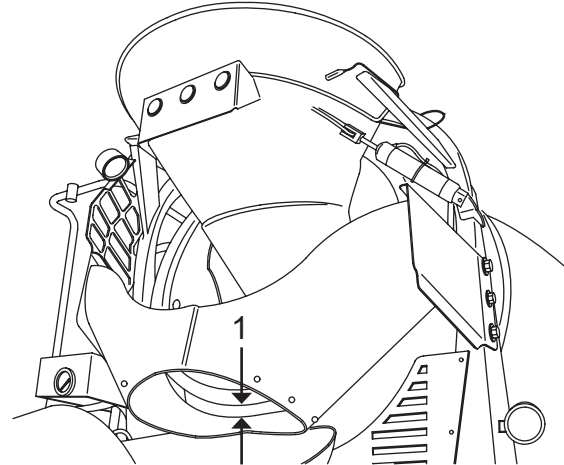

Figure 146

WARNING

Crush Hazard. Moving drum can crush you against debouncer. Keep yourself and tools clear of debouncer when drum turns. Failure to comply may result in serious personal injury or death.

Operation

7. Check the debouncer-to-drip ring clearance (Figure 147, Item 1), the clearance should be $3/8$ to $1/2$ inch (10 to 13 mm) at the closest point.

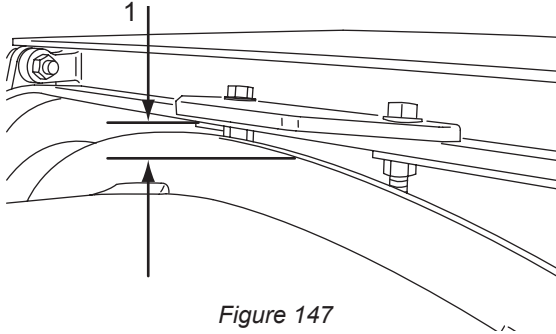

Figure 147

8. Check the drum flange bolt (Figure 148, Item 1) torque. (Refer to the Service Manual for torque values.) If a bolt turns during this check, that bolt must be removed and replaced with a new Grade 8 bolt.

NOTE

Grade 8 bolts can be purchased with or without a pre-applied threadlocker such as Loctite®. There are different torque values for bolts with and without a pre-applied threadlocker. Use the procedure that applies to your application.

New Grade 8 Bolt(s) **without** Pre-Applied Threadlocker:

- a. Clean the threads in the drum.
- b. Apply Red Loctite® to the threads of new Grade 8 bolts.
- c. Install and tighten the bolt(s) to the specified torque. (Refer to the Service Manual for torque value.)

New Grade 8 Bolt(s) **with** Pre-Applied Threadlocker:

- a. Clean the threads in the drum.
- b. Install and tighten new Grade 8 bolt(s) to the specified torque. (Refer to the Service Manual for torque value.)

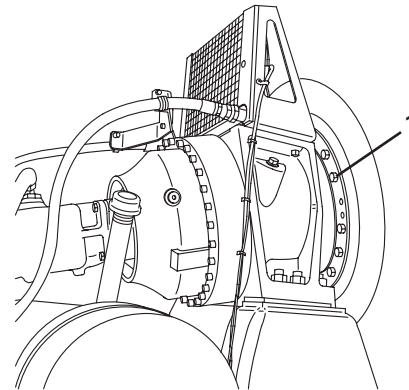

Figure 148

9. Lower charge hopper.
10. Remove your company's Lockout/Tagout procedure. If your company does not have a Lockout/Tagout procedure, follow OSHA 1910.147 and 1910.146 Confined Space as appropriate.

3.5.2 Concrete Removal

Refer to the Mixer Service Manual for concrete removal instructions.

3.6 Operation

WARNING

Crush Hazard. Be sure non-operating personnel are a safe appropriate distance from all areas of the mixer. Failure to comply may result in serious personal injury or death.

3.6.1 Mixer Controls

SAFETY NOTICE

Perform your company's Lockout/Tagout procedure. If your company does not have a Lockout/Tagout procedure, follow OSHA 1910.147 and 1910.146 Confined Space as appropriate.

Preventive Maintenance

- **Daily Checks** – The mixer controls are checked for proper operation by the operator or skilled service personnel.

Operate all functions to validate that they are operational. Verify that all indicator lights and alarms are operational.

4.0 Safety Decals

- **Daily Checks** – A complete walk around of the vehicle to inspect the safety decals should be performed every day before operation. If any of the safety decals are damaged, illegible, or missing, they must be replaced before operation.

The following safety decals are found on your concrete mixer. They warn of hazards related to the use of this equipment. Read and understand all safety decals before operating this equipment. All safety decals should be present and clearly readable at all times. If any safety decals on the equipment are not clearly readable, contact Revolution Concrete Mixers at (855) 202-6491 or www.streetsmartparts.com to order replacements. Use only Revolution replacement safety decals.

Preventive Maintenance

For information on any of the chassis safety decals, please contact the chassis manufacturer.

NOTE

Depending on the mixer configuration and optional equipment, the actual location of decals and/or placards may vary from the examples shown.

The table below contains part numbers for the individual safety decals.

NOTE

Specifications, appearance, and part numbers for safety decals are subject to change without notice.

No.	Part Number	Qty.	Comments
1	0214603	4	
2	1321144	2	
3	0129700	2	
4	0215072	2	
5	0215100	1	
6	0214504	1	

No.	Part Number	Qty.	Comments
7	Not Available Separately.	1	If needed, order part number 0214545.
8	1138174	1	
9	0155068	1	
10	1240555	1	
11	0215099	1	
12	0214515	1	
13	0215063	2	
14	9083.601930	2	
15	0214672	2	
16	0215097	1	
17	0215060	3	
18	0115118	1	
19	1130173	2	
20	0214502	1	
21	1659441	1	
22	0214512	2	
23	0214671	1	
24	0215064	2	

No.	Part Number	Qty.	Comments
25	0214724	2	
26	1130172	8	
27	1676092	1	
28	0215023	1	
29	0115117	1	
30	1676090	1	
31	0215119	1	
32	1676091	2	
33	1394101	1	
34	0115100	1	
35	1676089	1	
36	0129709	1	
37	1138173	1	
38	0214667	1	
39	0214666	1	
40	0215123	2	
41	0215095	1	
42	1676093	3	
43	1659440	1	
44	0215086	1	

No.	Part Number	Qty.	Comments
45	0215058	1	
46	1326014	1	
47	1420547	1	
48	1241178	1	
49	1138175	1	
50	1326487	1	
51	0214523	1	
52	1139944	1	
53	TMMB	1	
54	NA		
55	0214618	1	
56	0214648	1	
57	1420592	1	
58	1496869	1	
59	1597667	1	

4.1 Safety Decal and Placard Locations

4.1.1 Curb Side Views

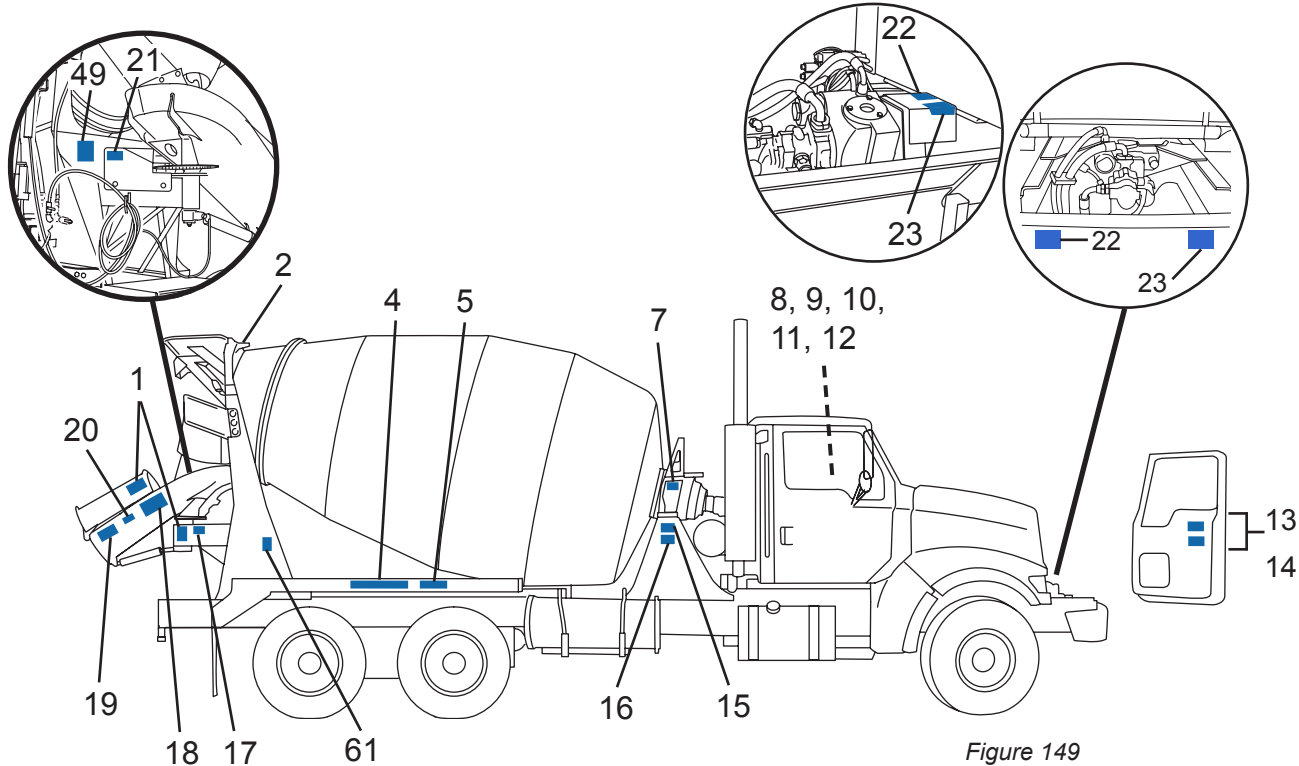

Figure 149

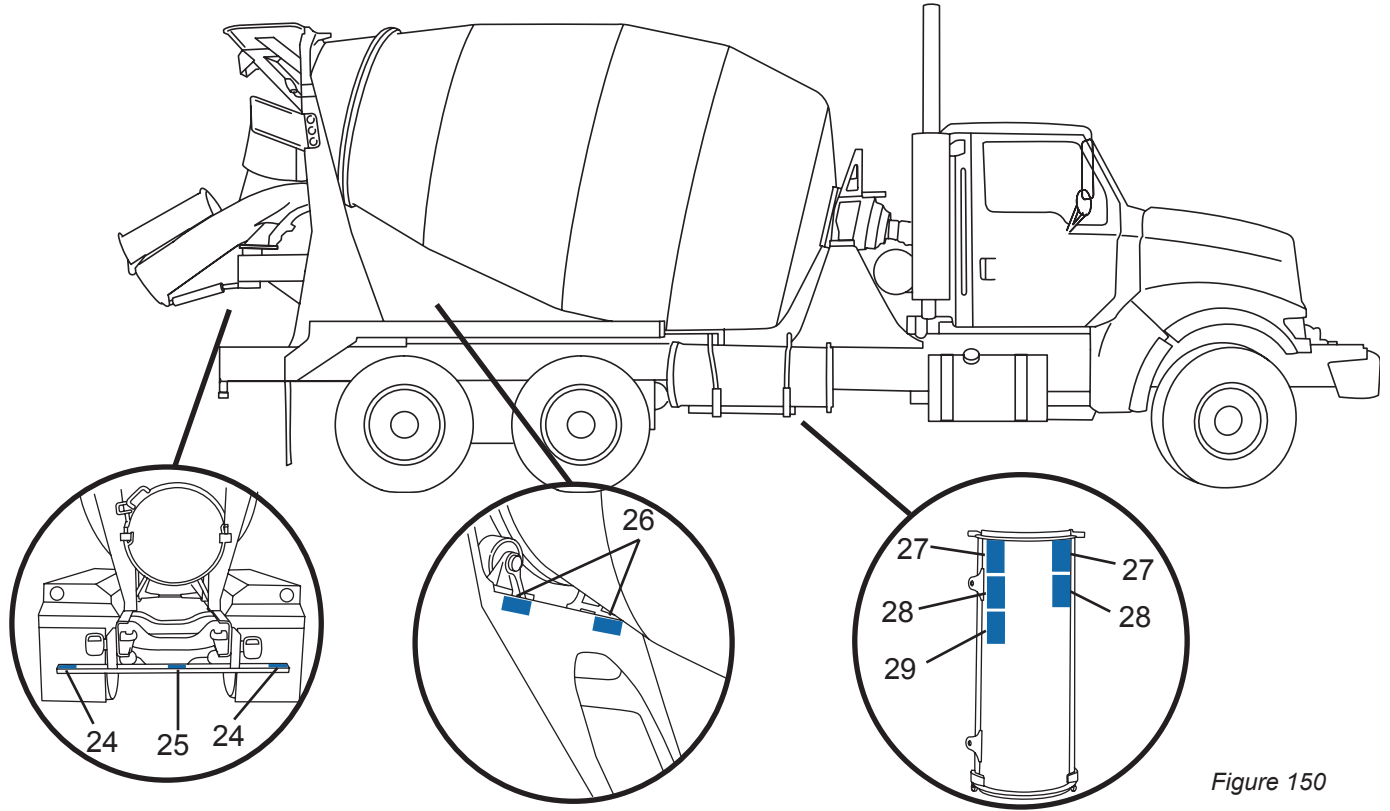

Figure 150

4.1.2 Street Side Views

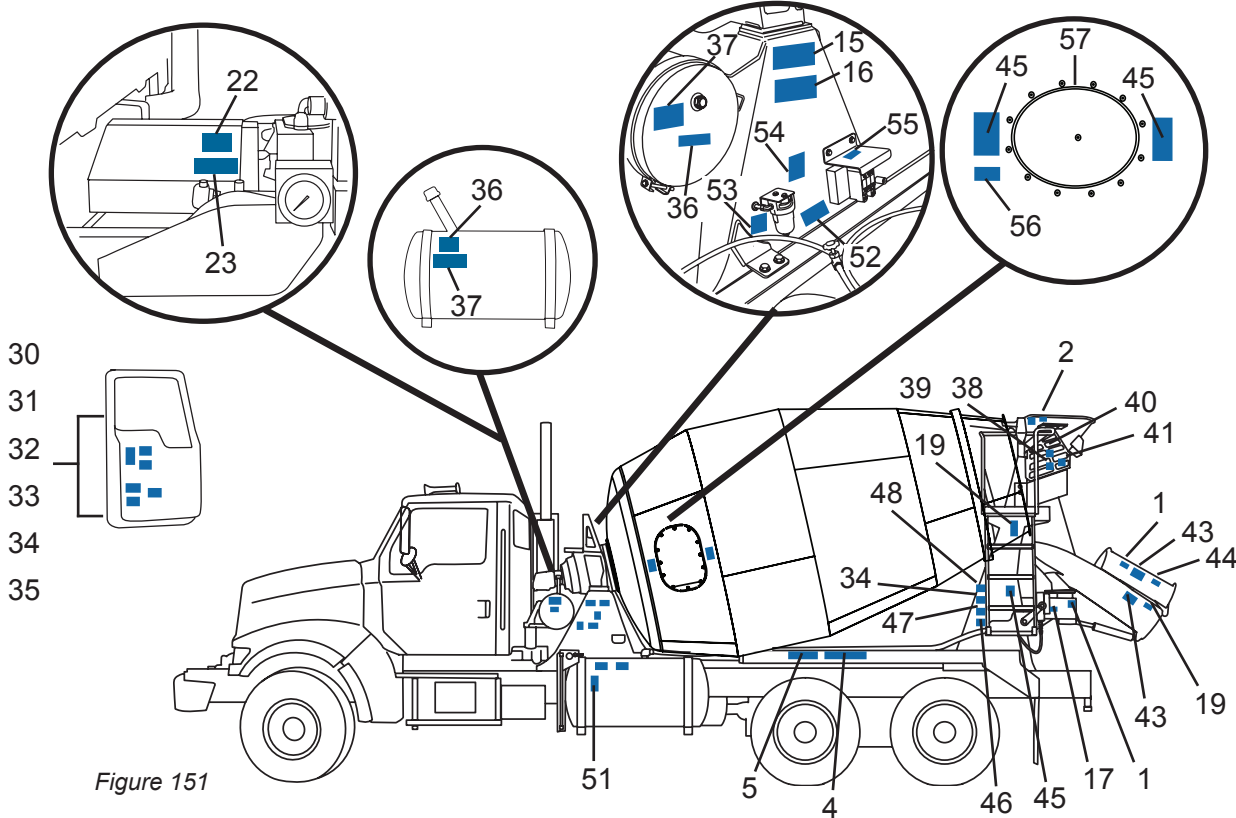

Figure 151

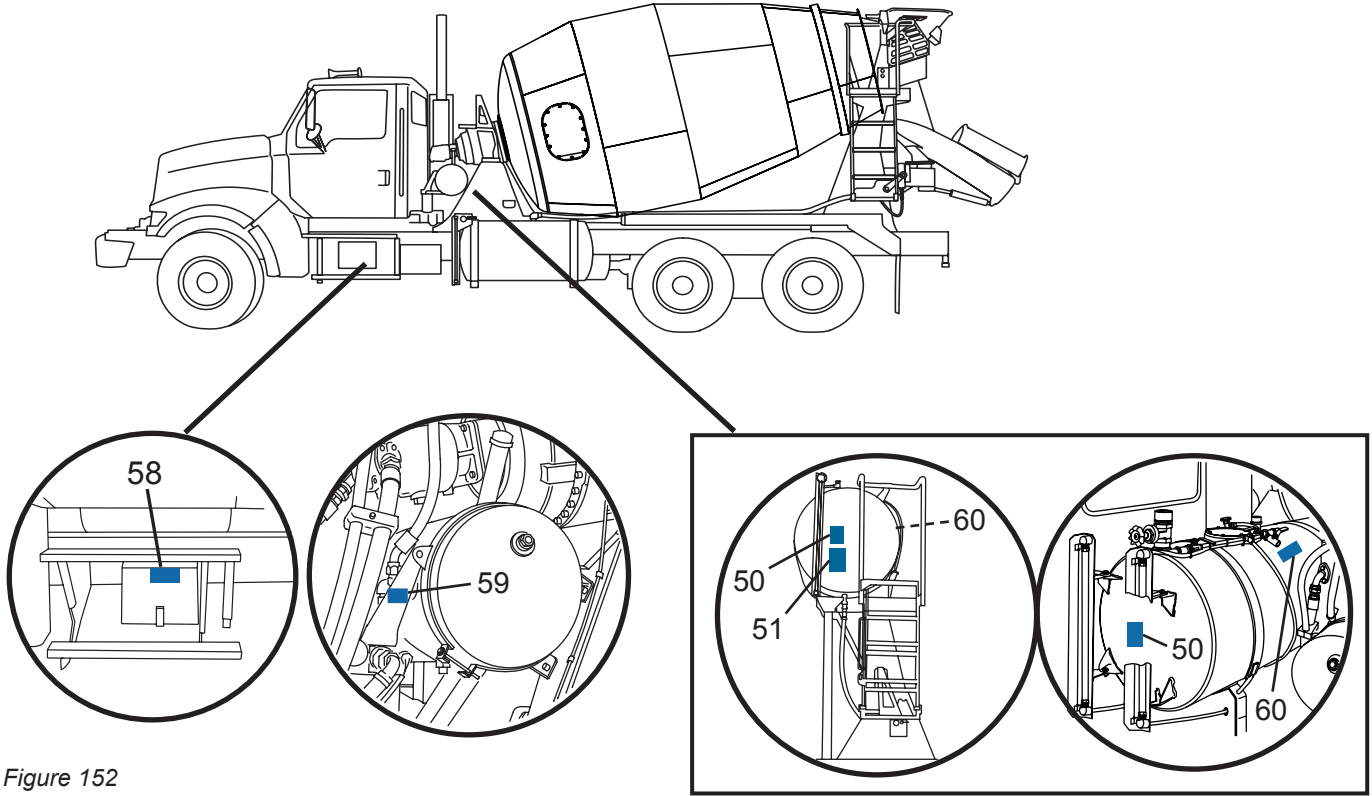

Figure 152

5.0 Optional Equipment Maintenance

5.1 Spray Bar Strainer

NOTE
Contaminants may vary, depending on the application.

The spray bar strainer (50 mesh) should be cleaned and inspected once a week.

1. Remove (unscrew) the cup (Figure 153, Item 3), and remove the cup and strainer (Figure 153, Item 4) from the strainer head (Figure 153, Item 1).
2. Clean the strainer (Figure 153, Item 4) with clear water. Inspect the strainer. Replace if torn or damaged.
3. Inspect the cup seal (Figure 153, Item 2). Replace if torn or damaged.
4. Install the strainer (Figure 153, Item 4) and cup (Figure 153, Item 3).

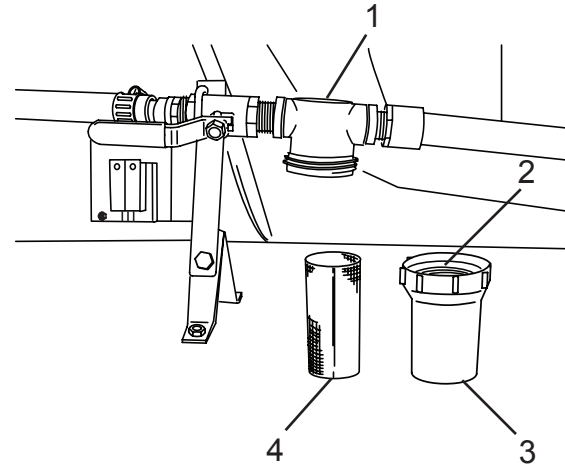

Figure 153

5.2 GPI® Water Meters

5.2.1 Battery Replacement

1. Remove four screws (Figure 154, Item 2) from the face of the meter and remove the faceplate (Figure 154, Item 1) from the meter body.

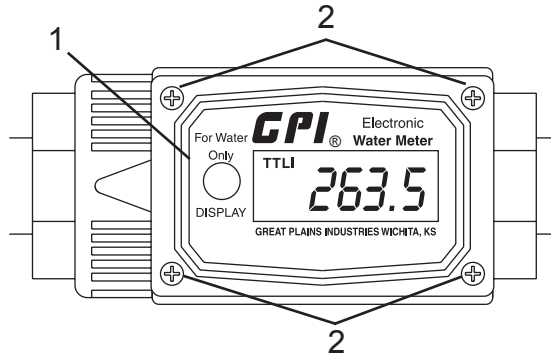

Figure 154

2. Remove the batteries, noting their orientation in the holder.
3. Inspect the terminals for corrosion. Clean as needed.
4. Install new batteries in the same orientation as noted during removal.

Preventive Maintenance

5. Inspect the O-ring to make sure it is fully seated in the housing.
6. Activate the display by briefly pressing the DISPLAY button (Figure 155, Item 4).
7. Check the display (Figure 155, Item 3) to verify that it is operating normally. Re-seat the batteries if needed.
8. Install the meter faceplate (Figure 155, Item 1) on the meter body with four screws (Figure 155, Item 2).

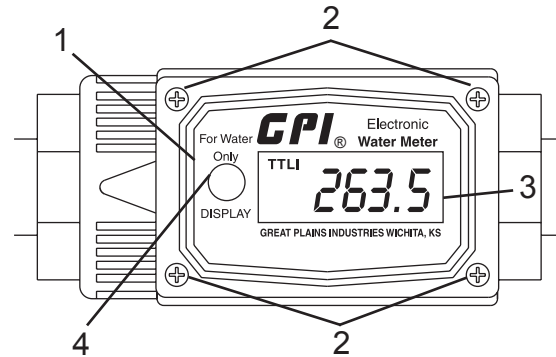

Figure 155

Preventive Maintenance

5.3 Optional Pusher Axle Maintenance

Refer to the vendor information supplied with the Mixer for maintenance and service information.

6.0 Lubrication

6.1 Daily Lubrication

Lubricate all the following points with a high-quality EP No. Lithium grease.

Daily lubrication intervals are based on a 10-hour day. If the Mixer is operated more hours per day or double shifted, the maintenance interval must be adjusted accordingly.

6.2 Daily Lubrication – Remote Lubrication System (If Equipped)

Mixers may be equipped with a remote lubrication system. This system positions grease fittings in easily accessible groups on the rear pedestal (Figure 156, Item 1), or in an alternate position on the discharge chute support pylon (Figure 157, Item 1). These fittings are connected to mixer components by tubes.

SAFETY NOTICE

Perform your company's Lockout/Tagout procedure. If your company does not have a Lockout/Tagout procedure, follow OSHA 1910.147 and 1910.146 Confined Space as appropriate.

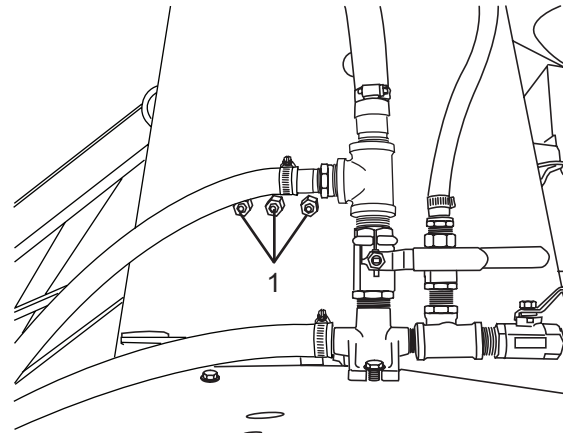

Figure 156

Standard Location

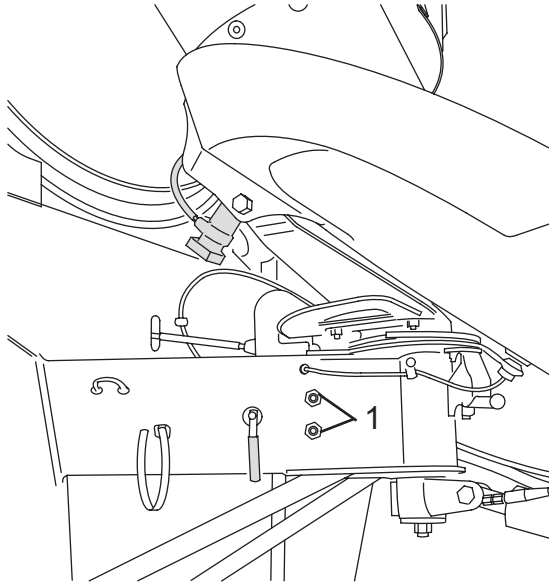

Figure 157

Alternate Location

6.3 Daily Lubrication – Central Lubrication Systems

Mixers may be equipped with one of several central lubrication systems. Refer to the vendor information supplied with the Mixer for operating and maintenance information.

SAFETY NOTICE
<p>Perform your company's Lockout/Tagout procedure. If your company does not have a Lockout/Tagout procedure, follow OSHA 1910.147 and 1910.146 Confined Space as appropriate.</p>

Lubrication Points		Lubricate Daily or Every 10 Hours	
Ref.	Description	No. of Fittings	Comments
A1	Drum Roller Bearings	2	Two Fittings – One Per Side
A2	Drum Roller Bearings – Remote Lubrication System	2	
A3	Drum Roller Bearings – Remote Lubrication System	2	Alternate Position
B	Drum Roller Track	—	Brush On

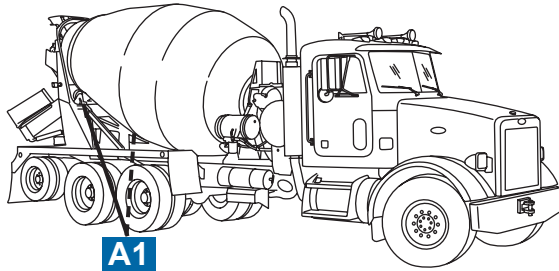

A1

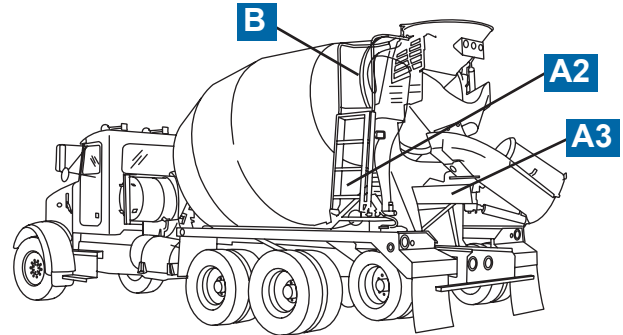

B

A2

A3

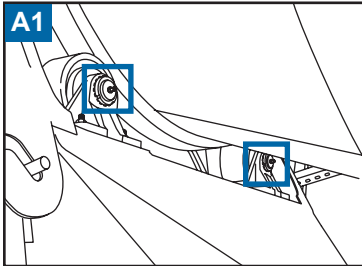

A1

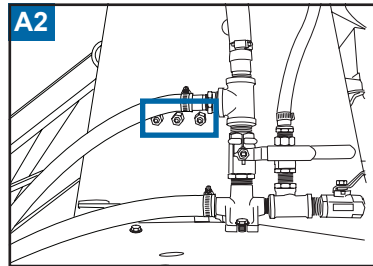

A2

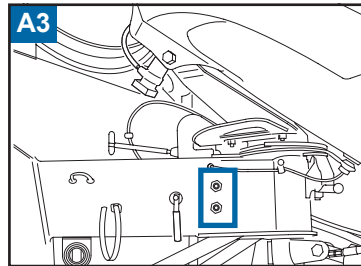

A3

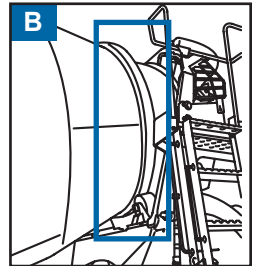

B

Preventive Maintenance

6.4 Weekly Lubrication

Lubricate all the following points with a high-quality EP No. 2 Lithium grease.

SAFETY NOTICE

Perform your company's Lockout/Tagout procedure. If your company does not have a Lockout/Tagout procedure, follow OSHA 1910.147 and 1910.146 Confined Space as appropriate.

Lubrication Points		Lubricate Weekly or Every 50 Hours	
Ref.	Description	No. of Fittings	Comments
C	PTO Shaft – Slip Joint	1	
C	PTO Shaft – U-Joint	2	Two Fittings – Front and Rear
D1	Main Chute Pivot	1	
D2	Main Chute Pivot – Remote Lubrication System	1	
E	Chute Manual Lock Shaft	—	Apply Grease to Shaft
F	Rear Drum Control Box	2	Two Fittings – One Per Side
G	Knee Braces	4	Two Fittings Per Side. One side called out in truck image below.

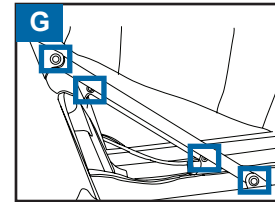
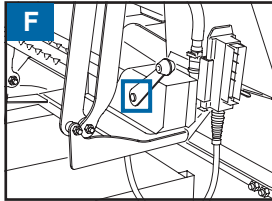
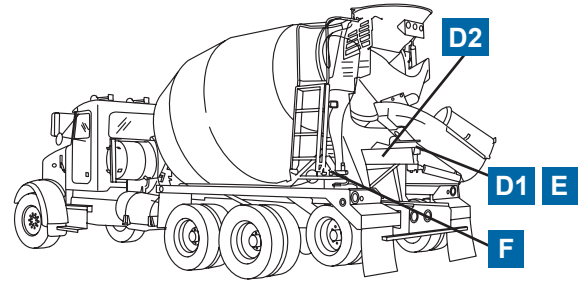
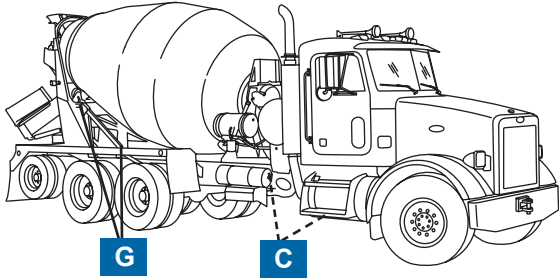
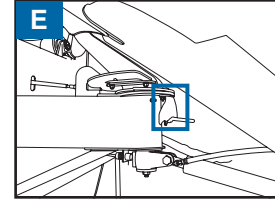
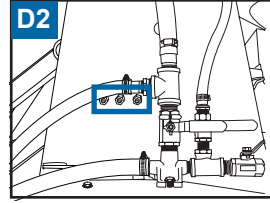
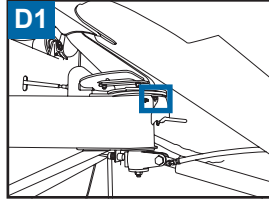
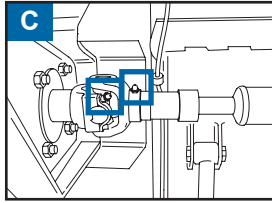

Preventive Maintenance

6.5 Semi-Annual Lubrication

Lubricate all the following points with a high-quality EP No. 2 Lithium grease.

Perform your company's Lockout/Tagout procedure.
If your company does not have a Lockout/Tagout procedure, follow OSHA 1910.147 and 1910.146 Confined Space as appropriate.

Lubrication Points		Lubricate Semi-Annually or Every 1250 Hours	
Ref.	Description	No. of Fittings	Comments
H	Drum Control Cables	–	Special Tool Required

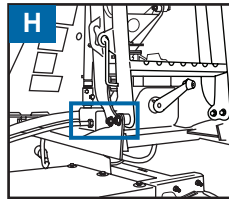
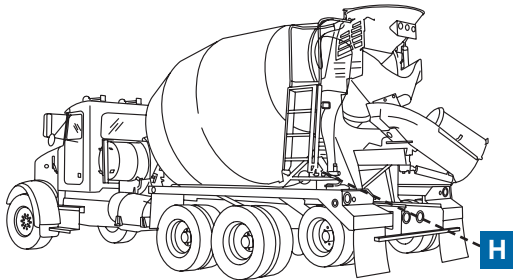

NOTES

Index

A

Auxiliary Function Icons..... 43

B

Battery Cable Disconnect..... 9

Before Placing the Mixer Into Service 37

 INSIGHT System Deactivate Transport Feature... 37

 Traditional Controls Deactivate Transport Feature 38

C

Cable Drum Control..... 57

Central Lubrication Systems..... 178

Chassis Options 197

 Pusher and Tag Axles 197

Chute Assist..... 160

Chute Blockers 164

Chute Operation 116

 Positioning the Discharge Chute Assembly 119

 Unfolding the Fold-Over Chute 116

 Using Chute Extensions..... 118

Complete Vehicle Document Decal..... 3

Concrete Slump Meter..... 172

 Setting the Digital Concrete Slump Meter for INSIGHT
 System Only 174

 Loading a Slump Calibration Profile 176

 Setting the Mechanical Concrete Slump Meter... 172

Control Functions for INSIGHT System..... 62

 Add AdMixture Function (If Equipped) 76

 Chute Lock Function 72

 Chute Raise/Lower and Swing Functions 73

 Constant Speed Function (Electronic Drum Controls

 Only)..... 69

 Drum Stop Operation 65

 Hopper, Chute Lock, and Chute Operation with

 Wireless Transmitter (If Equipped) 74

 Hopper Function 71

 Load Function (Electronic Drum Controls Only) ... 67

 Mix Function (Electronic Drum Controls Only)..... 68

 Rotating the Drum from the Joystick, Optional In-Cab

 Keypad, or Rear Pendant Keypad..... 63

 Rotating the Drum with the Wireless Transmitter

 (If Equipped)..... 64

 Start-Up Function..... 62

 Work Lighting Functions 75

D

Discharge Chute Vibrator Valve 163

Discharging the Load..... 120

Index

E

End-of-Day Cleaning Procedure.....	125
Exterior Systems Arrangement.....	35

F

Flip-Up Charge Hopper	166
Foldover Stop	165

H

Hydraulic Chute Swing	162
Hydraulic Fold-Over Chute	158

L

Loading the Mixer Drum	113
Working Around Concrete Pumps.....	114
Lubrication	
Daily Lubrication	221
Daily Lubrication - Central Lubrication Systems	224
Daily Lubrication - Remote Lubrication System (If Equipped)	221
Semi-Annual Lubrication	228
Weekly Lubrication.....	226

M

Manual Chute Lock.....	58
------------------------	----

Manual Drum Operation	61
INSIGHT Mixer System Instruments and Controls ..	39
Auxiliary Function Icons	43
INSIGHT System Enabled Package (Optional) ..	44
Cab Control Keypad (Optional).....	51
Cab Control Keypad (Standard).....	49
Drum Revolution Counters Screen Overview	42
Fuse Functions	59
Home/Drum Screen Overview	40
Manual Drum Operation.....	61
Optional Joystick for Drum Pause, Chute Up/Down Functions.....	53
Outside Controls	54
Cable Drum Control (If Equipped)	57
Manual Chute Lock.....	58
Rear Pendant Control Keypad.....	55
Speed/Direction Sensor Reading Screen Overview	41
Touch Screen Display Button Overview.....	47
Touch Screen Display Status Icons	48
Parts and Support.....	5
Traditional Cable Control System Instruments and Controls	93
Add Water Function	109
Cab Controls - Cab Control Box	93
Rocker Switch Functions	94
Fuse Functions	97
Manual Drum Operation.....	106

Outside Controls	97	Operating Procedures	197
Drum Control	98	Adjusting the Throttle Speed.....	111
Manual Chute Lock.....	101	Chute Operation.....	116
Rear Control Pendant.....	98	Discharging the Load	120
By-Passing the Rear Pendant.....	100	Drum Operation	111
Traditional Electronic Control System Instruments and Controls	76	End-of-Day Cleaning Procedure	125
Cab Controls - Cab Control Box	83	Loading the Mixer Drum.....	113
Rocker Switch Functions	84	Positioning the Truck for Discharge	115
Cab Controls - Cab Control Pendant	78	Returning from the Job Site	124
Rocker Switch Functions	79	Start-Up Procedure	110
Fuse Functions	91	Traveling to the Job Site	115
Outside Controls	87	Warm-Up Procedure	111
Rear Pendant Controls	88	Wash Down the Mixer Before Leaving the Job Site.....	121
By-Passing the Rear Pendant.....	89	Optional Equipment.....	158
Mixer Identification Plate and TMMB Certification Placard	1	Central Lubrication Systems	178
Mixer Serial Number Explanation	2	Chute Assist	160
O		Chute Blockers.....	164
Wireless Remote Control (Optional).....	180	Concrete Slump Meter	172
Control Buttons and Switches For INSIGHT System.....	180	Discharge Chute Vibrator Valve	163
Control Buttons and Switches For Traditional Controls	184	Flip-Up Charge Hopper	166
Wireless Remote Control (Optional) Troubleshooting	188	Foldover Stop.....	165
		Hydraulic Chute Swing.....	162
		Hydraulic Fold-Over Chute	158
		Lateral Protection Device	168
		Wireless Remote Control (Optional)	180
		Preco for NSIGHT System.....	170
		Right Hand Turn Audible Warning System.....	168

Index

Swing Away Throat (SAT) Charge Hopper.....	167
Optional Equipment Maintenance	
GPI Water Meters	220
Optional Pusher Axle Maintenance	221
Spray Bar Strainer	219

P

Positioning the Truck for Discharge.....	115
Preventive Maintenance Daily Checks	
Electrical System	209
Hydraulic System	208
Mechanical System.....	211
Operation	218
Pneumatic System	210
Safety Signs.....	208
Standard (Steel) Drum	215
Preventive Maintenance Intervals	201
Proper Safety Equipment	12

R

Rear Pendant Control Keypad.....	55
Reporting Safety Defects.....	10

S

Safety Equipment	10
Safety Information	13

Safety Signs	29
Safety Sign and Placard Locations	31
Speed/Direction Sensor Reading Screen Overview	41
Swing Away Throat (SAT) Charge Hopper	167

T

TMMB Certification Placard.....	1
Traveling to the Job Site	115
Troubleshooting Chart	230

W

Wash Down the Mixer Before Leaving the Job Site	121
Water System Functions	148
Auto Washout System for INSIGHT System (Optional Equipment)	150
Spray Bar (Optional Equipment).....	152
Water Meter Function (Optional Equipment).....	153
Water System Functions (Optional Equipment)	
Wash-Out Hoses.....	148
Water Tanks.....	201

This Page Intentionally Left Blank



REVOLUTION™
CONCRETE MIXERS

(855) 202-6491